

**Specification Status: Released**

HCRTTP-mini-D is low resistance, surface mountable thermal protector which can be installed on PCB using surface mount assembly and reflow process. By using specified solder paste in the user's system, HCRTTP-mini-D can protect the components on the user's PCB from overheating when the temperature is higher than the melting point of the solder paste.

**1. Configuration and Dimension:**

**Terminal Material: C1100 1/2H (Tough-Pitch Copper)**  
**Thickness: 0.6mm**  
**Plating: Ni/Tin**

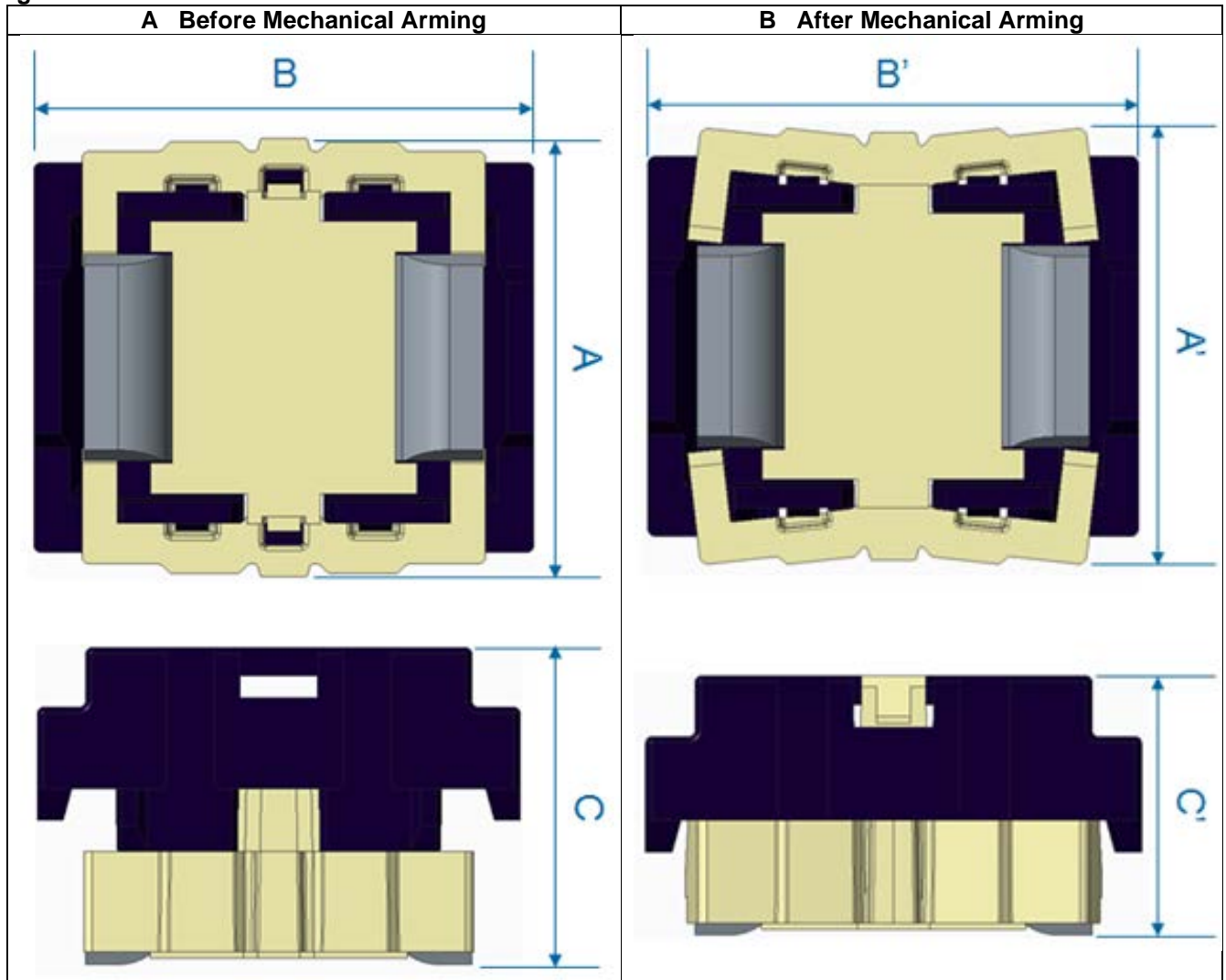

**Table-1. Dimensions:**

	Before Mechanical Arming						After Mechanical Arming					
	A		B		C		A'		B'		C'	
	Min	Max	Min	Max	Min	Max	Min	Max	Min	Max	Min	Max
mm	6.14	7.14	7.00	8.00	4.8	5.2	6.83	7.83	7.00	8.00	3.8	4.2
in	0.242	0.281	0.276	0.315	0.189	0.205	0.269	0.308	0.276	0.315	0.150	0.165

**2. Marking: Each lot of devices is marked on the body for traceability.**

- □\_D (Terminal type)
- □□□□\_ Batch Number

**3. Ratings & Spring Characteristics**

**Table 2. Ratings**

DC Open Voltage (Vdc)	DC Interrupt Current (A)	Operating Temperature (°C)		Resistance @ 23°C (μΩ)		
		Min	Max	Min	Typ.	Max
Max	Max					
60	200A/60V 300A/48V 500A/24V	-55	150	50	67.5	85

Note 1: Performance capability at these conditions can be influenced by board design.  
Performance should be verified in the user's system.

Note 2: Resistance should be measured by a 4 wired method unless otherwise specified.

**Table 3. Cap Integrity**

	Min	Typ.	Max	Units
Vertical pull force			3	N

**4. Arming**

Arming is to occur after surface mount installation.

Method: Cap depressed manually or by mechanical plunger



**Warning:** The device will not function without proper arming.  
If the device will be depressed by mechanical plunger, the plunger speed should be verified in the user's process.

**Table 4. Arming Recommendation:**

Description	Min.	Typ.	Max.	Units
Arming Force (Normal to PCB surface)	35	40	45	N
Distance of travel	0.94	1.00	1.06	mm

**5. Recommended Solder Pad Layout (Dimensions in mm):**

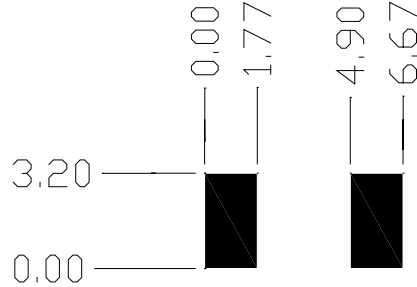

**6. Recommended Solder Stencil Opening (Dimensions in mm):**

Stencil thickness used for testing: 0.110 ~ 0.140mm

Solder paste used for testing: Indium 5.8LS, SAC 305 (96.5% tin, 3% silver and 0.5% copper)

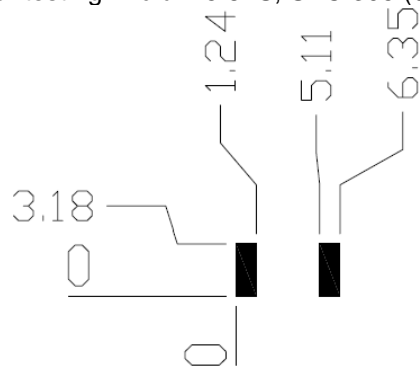

**7. Solder Reflow Recommendation**

As per JEDEC J-STD-020D

**Classification Reflow Profiles**

Profile Feature	Pb-Free Assembly
<b>Average ramp-up rate (T<sub>S</sub>MAX to T<sub>P</sub>)</b>	3°C/second max.
<b>Preheat</b>	
● Temperature min. (T <sub>S</sub> MIN)	150°C
● Temperature max. (T <sub>S</sub> MAX)	200°C
● Time (T <sub>S</sub> MIN to T <sub>S</sub> MAX)	60 - 120 seconds
<b>Time maintained above:</b>	
● Temperature (T <sub>L</sub> )	217°C
● Time (t <sub>L</sub> )	60 - 150 seconds
<b>Peak/Classification temperature (T<sub>P</sub>)</b>	260°C
<b>Time (t<sub>P</sub>) within 5°C of the specified classification temperature (t<sub>c</sub>)</b>	
Time (t <sub>c</sub> )	30 seconds max.
<b>Ramp-down rate</b>	6°C/second max.
<b>Time 25°C to peak temperature</b>	8 minutes max.

Note: All temperatures refer to topside of the package, measured on the package body surface.

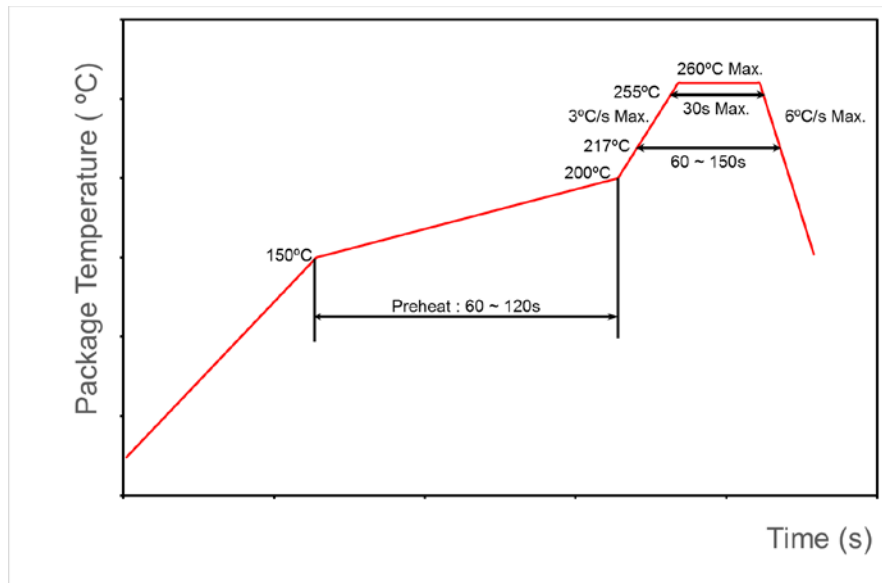

**8. Referenced Performance**

Results obtained on 44.4mm x 57.2 mm x 1.6mm of 2-sided FR4 board T4485 with 4.0 oz. Copper Trace. HCRTTP-mini-D device pad connection of

- 374 sq. mm 4.0 oz. copper heat spreader connected to P1 Pad.
- 327 sq. mm 4.0 oz. copper heat spreader connected to P2 Pad.

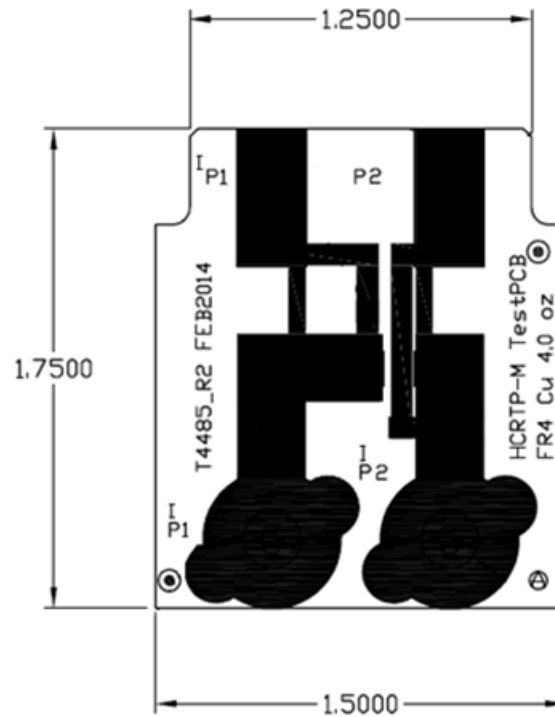

HCRTP-mini-D device surface-mounted on test board T4485 using solder paste SAC 305 with recommended pad layout and solder stencil opening and thickness.

Post reflow resistance based on SMT 1x reflow as outlined in solder reflow recommendation.

Results are highly installation-dependent. Users should confirm for their own application.

**Table 5. Referenced performance.**

Performances		Min	Typ.	Max	Units
Post Reflow Resistance	@ 23±3°C	50	100	150	μΩ
	@ 150±3°C	110	155	200	
Hold Current	@ 23±3°C			90	A
	@ 140±3°C			45	
Max Interrupt Current	60Vdc			200	A
	48Vdc			300	A
	24Vdc			500	A
Open Temperature	Zero Bias	212	220	228	°C

Post reflow resistance should be measured by a 4 wired method.

**9. Packaging Information:**

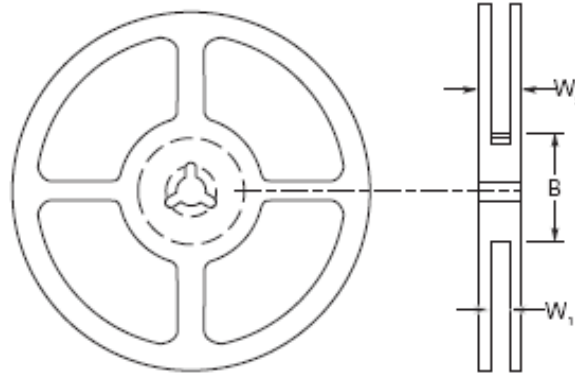

	B		W <sub>1</sub>		W <sub>2</sub>	
	Min	Max	Min	Max	Min	Max
mm	79	81	16.5	18.5	20.5	22.5
Inch	3.11	3.19	0.65	0.73	0.81	0.89

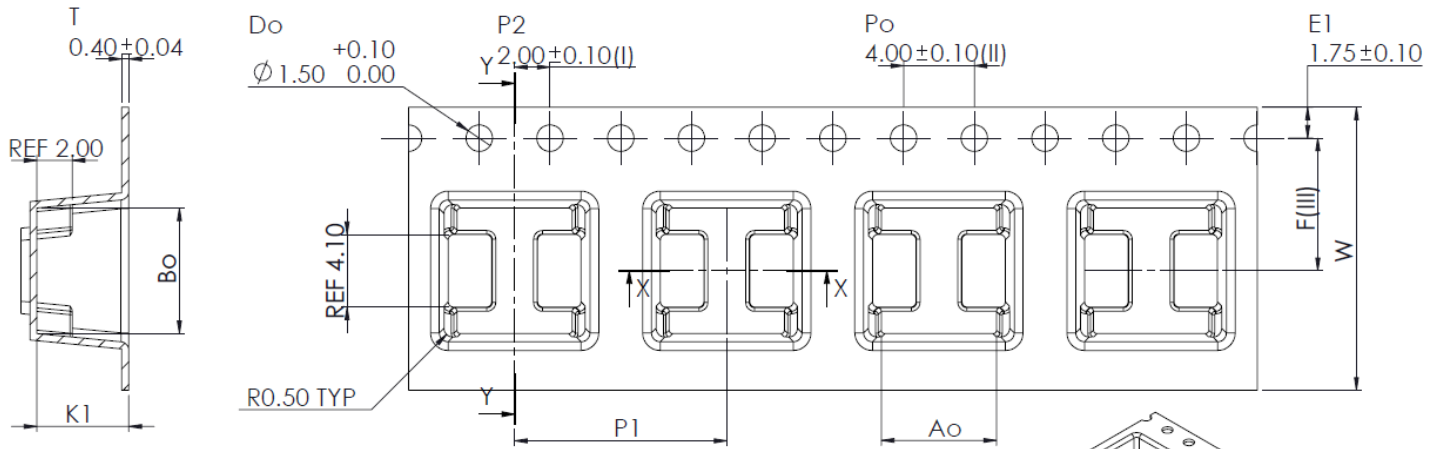

SECTION Y-Y

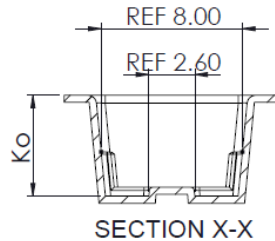

SECTION X-X

	Ao		Bo		Ko		K1		F		P1		W	
	Min	Max	Min	Max	Min	Max	Min	Max	Min	Max	Min	Max	Min	Max
mm	6.46	6.66	7.04	7.24	5.6	5.8	5.1	5.3	7.4	7.6	11.9	12.1	15.7	16.3
Inch	0.25	0.26	0.28	0.29	0.22	0.23	0.20	0.21	0.29	0.30	0.47	0.48	0.62	0.64

Precedence: This specification takes precedence over documents referenced herein.  
Effectivity: Reference documents shall be the issue in effect on the date of invitation for bid.

**Important Installation Instructions :**

- Note 1: HCRTP-mini-D devices are to be board-mounted using solder paste SAC 305 (96.5% Tin, 3% Silver, and 0.5% Copper).
- Note 2: HCRTP-mini-D devices are not compatible with conformal coating. If selective coatings are used, avoid covering the HCRTP-mini-D device, and it needs to be verified in the user's system with their own risk.
- Note 3: HCRTP-mini-D devices are not to be reworked in any manner which affects values stated in Table 2.

**MATERIALS INFORMATION**

**RoHS Compliant**

Directive 2002/95/EC  
Compliant

**ELV Compliant**

Directive 2000/53/EC  
Compliant

**Pb-Free**



**Halogen Free\***



\* Halogen Free refers to: Br≤900ppm, Cl≤900ppm, Br+Cl≤1500ppm.

Information furnished is believed to be accurate and reliable. However, users should independently evaluate the suitability of and test each product selected for their own applications. Littelfuse products are not designed for, and shall not be used for, any purpose (including, without limitation, military, aerospace, medical, life-saving, life-sustaining or nuclear facility applications, devices intended for surgical implant into the body, or any other application in which the failure or lack of desired operation of the product may result in personal injury, death, or property damage) other than those expressly set forth in applicable Littelfuse product documentation. Warranties granted by Littelfuse shall be deemed void for products used for any purpose not expressly set forth in applicable Littelfuse documentation. Littelfuse shall not be liable for any claims or damages arising out of products used in applications not expressly intended by Littelfuse as set forth in applicable Littelfuse documentation. The sale and use of Littelfuse products is subject to Littelfuse Terms and Conditions of Sale, unless otherwise agreed by Littelfuse.