

THIS DRAWING AND THE INFORMATION CONTAINED WITHIN IT ARE CONFIDENTIAL AND MAY NOT BE COPIED OR DISCLOSED WITHOUT THE WRITTEN PERMISSION OF LITTELFUSE.

| REVISIONS |      |   |          |             |
|-----------|------|---|----------|-------------|
| ZONE      | REV. | DESCRIPTION                               | DATE     | APPROVED    |
|           | A    | ECO #02609 RELEASED PART                  | 12/23/02 |             |
|           | B    | ECO #03189 NOTES & VIEW                   | 05/30/03 |             |
|           | C    | ECO # 03733 DIMENSION & VIEW              | 12/24/03 |             |
|           | D    | ECO #521068 UPDATE DIMENSION<br>C. MILLER | 7/22/19  | E.FERNANDEZ |

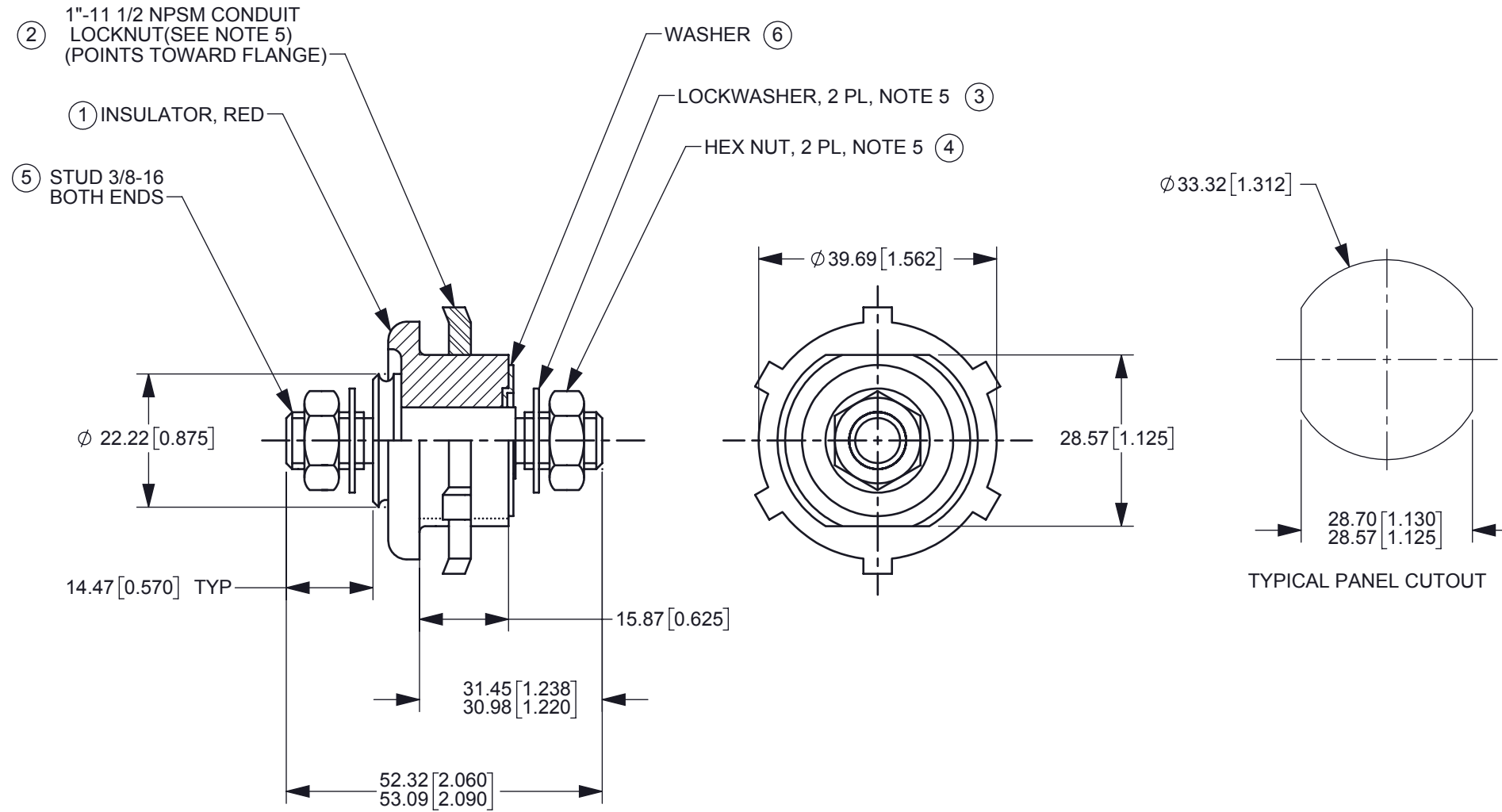

- NOTES:
1. ALL STEEL PARTS PLATED
  2. ALL DIMENSIONS ARE REFERENCE ONLY
  3. MOUNTING THREADS 1"-11 1/2 NPSM-  
MOUNTING TORQUE 10.8-13.5 Nm  
(8-10 FT LBS) NOT TO EXCEED  
13.5 Nm (10 FT LBS)
  4. STUD 3/8"-16 TIGHTENING TORQUE  
8.1-10.8 Nm (6-8 FT LBS)
  5. ALL HARDWARE SUPPLIED IN BAG

|   |  |  |
|---|--|--|
| ●   |  | FIT/ FUNCTION CRITICAL CHARACTERISTICS SYMBOL  |
| <S>   |  | SAFETY/ COMPLIANCE CRITICAL CHARACTERISTICS SYMBOL   |
| CPK   |  | DENOTES CPK DIMENSIONS MINIMUM CPK VALUE   |
| ST  |  | DENOTES A CHARACTERISTIC THAT PROVIDES AN INDICATION OF PROCESS PERFORMANCE PROCEDURE FOR MEASUREMENT AND TRACKING TO BE DEFINED IN LITTELFUSE INSPECTION INSTRUCTIONS |
| CP  |  | DENOTES CP DIMENSIONS. -MINIMUM CP VALUE MUST BE WITHIN THE DIMENSIONAL LIMITATIONS SHOWN ON DRAWING AND INITIALLY LOCATED TO ALLOW FOR MAXIMUM TOOL LIFE              |
| DIMENSION: MM TOLERANCES UNLESS OTHERWISE SPECIFIED<br>ONE PLACE DECIMAL ± 0.5      THREE PLACES DECIMAL ± 0.100<br>TWO PLACES DECIMAL ± 0.20      ANGULAR ± 2° |  |  |

| ITEM | PART NO. | COMPONENT NAME    | QTY |
|------|----------|-------------------|-----|
| 6    | 88706    | WASHER            | 1   |
| 5    | 83084    | STUD 3/8"-16      | 1   |
| 4    | 84000    | HEX NUT 3/8"-16   | 2   |
| 3    | 85049    | LOCKWASHER        | 2   |
| 2    | 83320    | NUT LOCK 1-11 1/2 | 1   |
| 1    | 87394-R  | INSULATOR, RED    | 1   |

|   |                                |      |      |          |         |         |  |          |  |  |  |  |  |
|---|--------------------------------|------|------|----------|---------|---------|--|----------|--|--|--|--|--|
| <table border="1"> <tr> <td>NAME</td> <td>DATE</td> </tr> <tr> <td>G.A.</td> <td>12/17/02</td> </tr> <tr> <td>CHECKED</td> <td>A.HOANG</td> </tr> <tr> <td></td> <td>07/25/19</td> </tr> <tr> <td></td> <td></td> </tr> <tr> <td></td> <td></td> </tr> </table> | NAME                           | DATE | G.A. | 12/17/02 | CHECKED | A.HOANG |  | 07/25/19 |  |  |  |  | <p><b>Littelfuse</b><br/>Expertise Applied   Answers Delivered</p> |
| NAME  | DATE                           |      |      |          |         |         |  |          |  |  |  |  |  |
| G.A.  | 12/17/02                       |      |      |          |         |         |  |          |  |  |  |  |  |
| CHECKED   | A.HOANG                        |      |      |          |         |         |  |          |  |  |  |  |  |
|   | 07/25/19                       |      |      |          |         |         |  |          |  |  |  |  |  |
|   |                                |      |      |          |         |         |  |          |  |  |  |  |  |
|   |                                |      |      |          |         |         |  |          |  |  |  |  |  |
| FORM NO: CVP-PE40-0004 REV A<br>THIRD ANGLE PROJECTION  |                                |      |      |          |         |         |  |          |  |  |  |  |  |
| SIZE B      DWG. NO. 46211-R      REV. D  | TITLE<br><b>FEED THRU STUD</b> |      |      |          |         |         |  |          |  |  |  |  |  |
| DO NOT SCALE DRAWING  | SCALE 1:1                      |      |      |          |         |         |  |          |  |  |  |  |  |
| SHEET 1 OF 1  |                                |      |      |          |         |         |  |          |  |  |  |  |  |