

5584-15

| MM | IN |
|--------|-------------|
| 0.25 | 0.010 |
| 0.96 | 0.032 |
| 1.82 | 0.072 |
| 6.35 | 0.250 |
| 11.88 | 0.468 |
| 15.88 | 0.625 |
| 17.47 | 0.688 |
| 25.40 | 1.000 |
| 33.65 | 1.325 |
| 101.60 | 4.000 |
| 279.40 | 11.000 |
| 3.0 mm | 2^{12} GA |

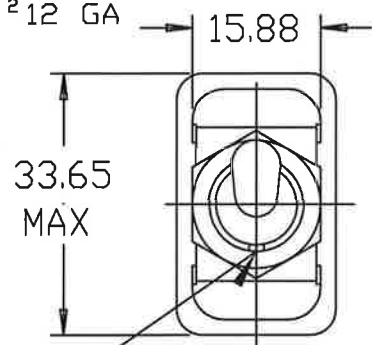

1.82 X 0.96
DEEP KEYWAY

63.5 MM +/- 12.7 [2.5 +/- .5"]
SEE NOTE 7 ©

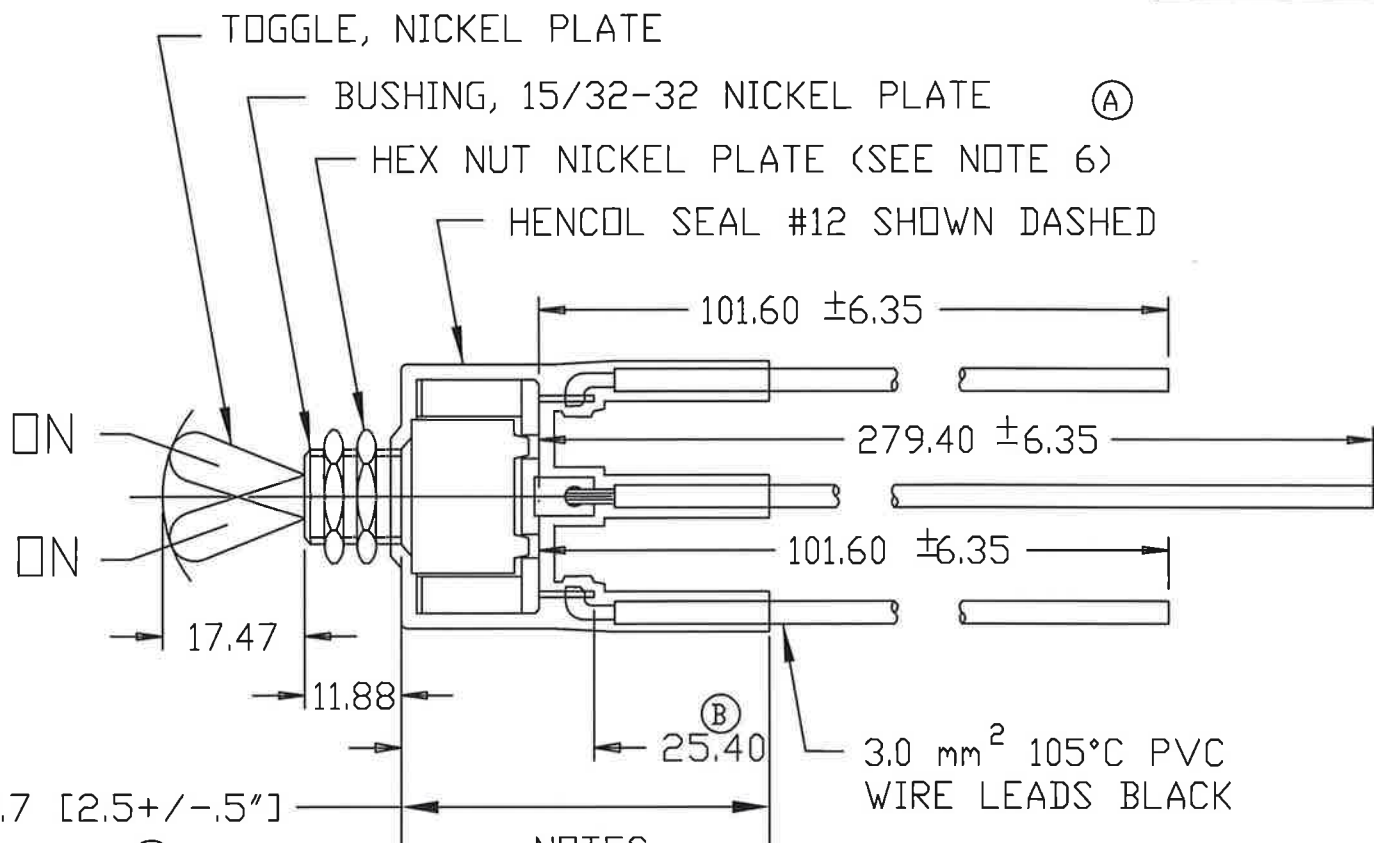

NOTES:

1. SILVER CONTACTS
2. 25 AMPS @ 12VDC LAMP LOAD
35 AMPS @ 12VDC INDUCTIVE LOAD
3. O-RING SEAL IN BUSHING
4. ALL STEEL PARTS PLATED
5. ALL DIMENSIONS ARE REFERENCE

6. 1 HEX NUT ASSBLD; 1 NUT SHIPPED LOOSE (A)
7. THIS DIMENSION MUST BE MAINTAINED ©

METRIC

| LET. | WAS | DATE | BY | LET. | WAS | DATE | BY | MATERIAL | DRAWN | CHK | APVD | SCALE | EX25260 | DATE DRAWN |
|------|-----|------|----|------|------------|---------|-----|--|-------|-----|------|-------|---------------------|------------------|
| | | | | | | | | | BL | | | 1:1 | | 4/13/93 |
| | | | | C | ECR #10524 | 6/10/14 | GA | FINISH | | | | | | DATE BLUEPRINTED |
| | | | | B | ECN #25389 | 6/15/93 | MJT | | | | | | | |
| | | | | A | ECN 25385 | 6/9/93 | BL | | | | | | | |
| | | | | | ISSUED | 4/22/93 | AF | TOLERANCES METRIC ± 0.25 ANGLE ± | | | | | | |
| | | | | | | | | | | | | | SWITCH, TOGGLE SPDT | 5584-15 |



Cole Hersee Co.
20 OLD COLONY AVENUE, BOSTON, MA., U.S.A., 02127