

MOUNTING PATTERNS

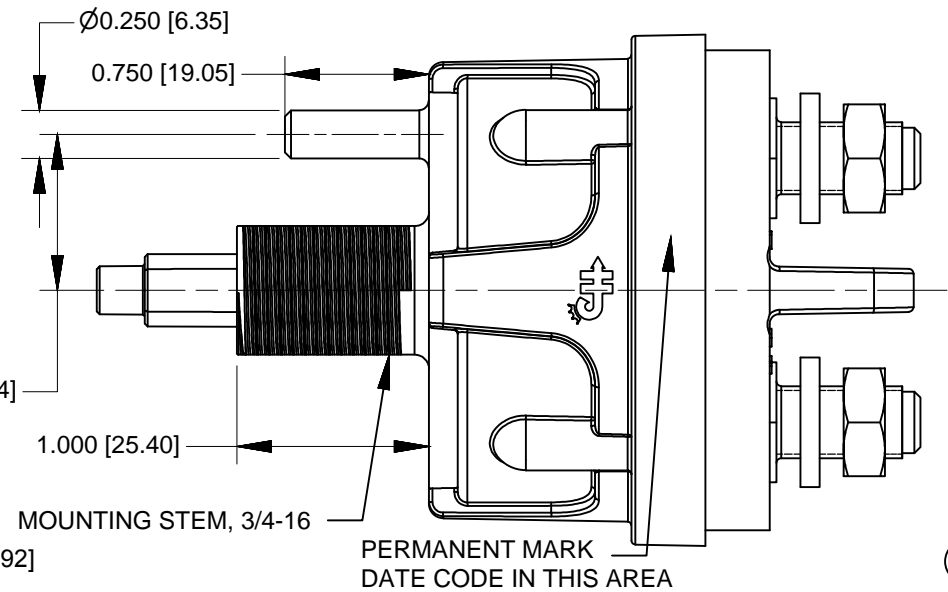
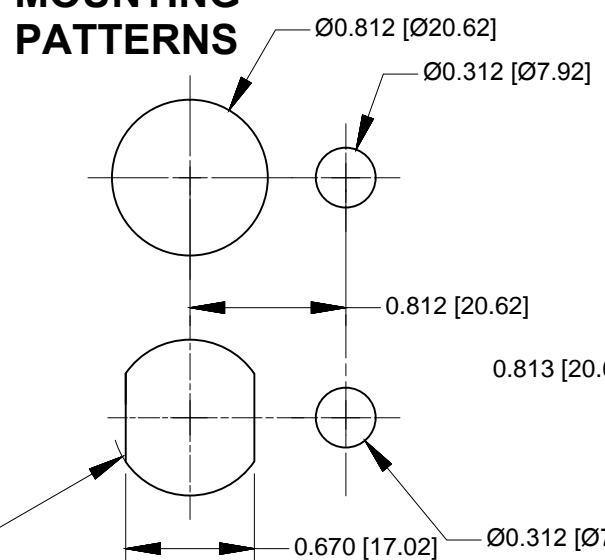

- NOTES:**
1. ALL DIMENSIONS ARE REFERENCE ONLY
 2. ALL STEEL PARTS PLATED
 3. CONTACT SURFACES COPPER
 4. RECOMMENDED LOCK SHANK SIZE 5/16" (0.312[7.93]) DIA
 5. TESTED TO IP68
 6. RATINGS:
CONTINUOUS DUTY:
12 Vdc: 300 AMPS; 24 Vdc: 250 AMPS; 36 Vdc: 200 AMPS
INTERMITTENT DUTY:
1000 AMPS FOR 90 SECONDS ON; 5 MINUTES OFF
2000 AMPS FOR 30 SECONDS ON; 5 MINUTES OFF
 7. SWITCH MUST BE INSTALLED WITH BEZEL
 8. CUSTOMER SUPPLIED TERMINALS SHOULD BE IN DIRECT CONTACT WITH BASE OF STUD
 9. STUD TORQUE 70-90 IN-LBS [7.9-10.1 N.m]
 10. MOUNTING STEM HEX NUT TORQUE 18 FT LBS [24.4 N.m]
 11. PANEL THICKNESS RANGE: 0.032-0.450 [0.81-11.43]
 12. PARTS SHIPPED BAGGED
 13. FOR ADDITIONAL KNOB RETENTION, ASSEMBLE SCREW TO SHAFT THEN INSERT CAP
 14. ROTATION OF THE STUD WITHIN THE BASE UP TO 5° IS NORMAL AND DOES NOT EFFECT OPERATION OR SEALING

| Revision Control Record | | | | Rev. | Description of Change | ECN No. | Date | Tolerances Unless otherwise specifically noted, the following are default tolerances: 2-places ± 0.02 " 3-places ± 0.005 " Angular $\pm 1'$ Metric: Shown in [] refers to equivalent English Dim Tol "REF." or an Asterisk (*) = Non-Toleranced Reference Dimension, shown for clarification purposes only. NOTE: All tolerances are Non-Cumulative. | | PROPRIETARY INFORMATION This Engineering Drawing, and the information contained herein, is proprietary to Cole Hersee Company and may not be disclosed, re-produced, or in any other way transferred or communicated to any other party without the express written consent of an authorized representative of Cole Hersee Company. | | Special Characteristics: CC Critical Characteristic, relating to Safety and/or Regulatory Compliance X Significant Characteristic relating to Process Control KC Control Dimension relating to Form - Fit - Function as defined by Cole Hersee Company and/or the Customer | | Cole Hersee Co. 20 Old Colony Ave., South Boston, MA, 02127 Phn: 617-268-2100 Web: www.colehersee.com | | | | |
|-------------------------|------------------------------|---------|----------|------|-----------------------|---------|------|---|------------------|---|------------|---|--------------------|--|---------------------|-----------------|---------------|----------|
| Rev. | Description of Change | ECN No. | Date | | | | | | | | | | | | | | | |
| A | ADD STAINLESS STEEL HARDWARE | 12328 | 10/29/12 | | | | | | | | | | | | | | | |
| B | ADD CE MARK & NOTE | 09525 | 09/30/13 | | | | | | | | | | | | | | | |
| | | | | | | | | FORM CHT-6 (2/07) | Used On or Ref.: | 75920, EX28988 | Scale: 1:1 | By: DPS | Date Drawn: 9/4/12 | Pg. 1 of 1 | Drawing / Part No.: | 75920-10 | Current Rev.: | B |

Description: SW, ROT, MAST DISC