

MM	IN
.25	.010
1.52	.060
2.79	.110
9.14	.360
9.39	.370
15.74	.620
46.48	1.830
47.49	1.870
3.17	.125
1.01	.040
1.65	.065
10.41	.410
16.49	.413

SEQ	DEPT.	OPERATING INSTRUCTIONS	DIE	MACH

**956-6310**

**COLE-HERSEE CO.**  
 NPM 6-6-79  
 EX-18452

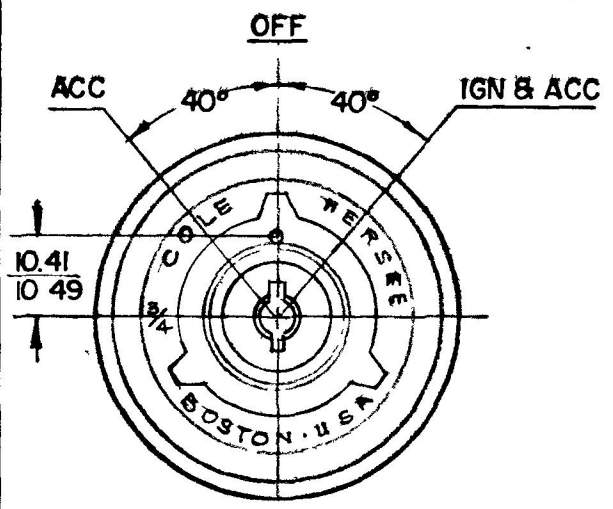

RATINGS AT 12V DC	
ACC. CIRCUIT	30 AMPS
IGN.	10

APPLICABLE SAE STANDARDS OR RECOMMENDED PRACTICE SAE J259

**METRIC**

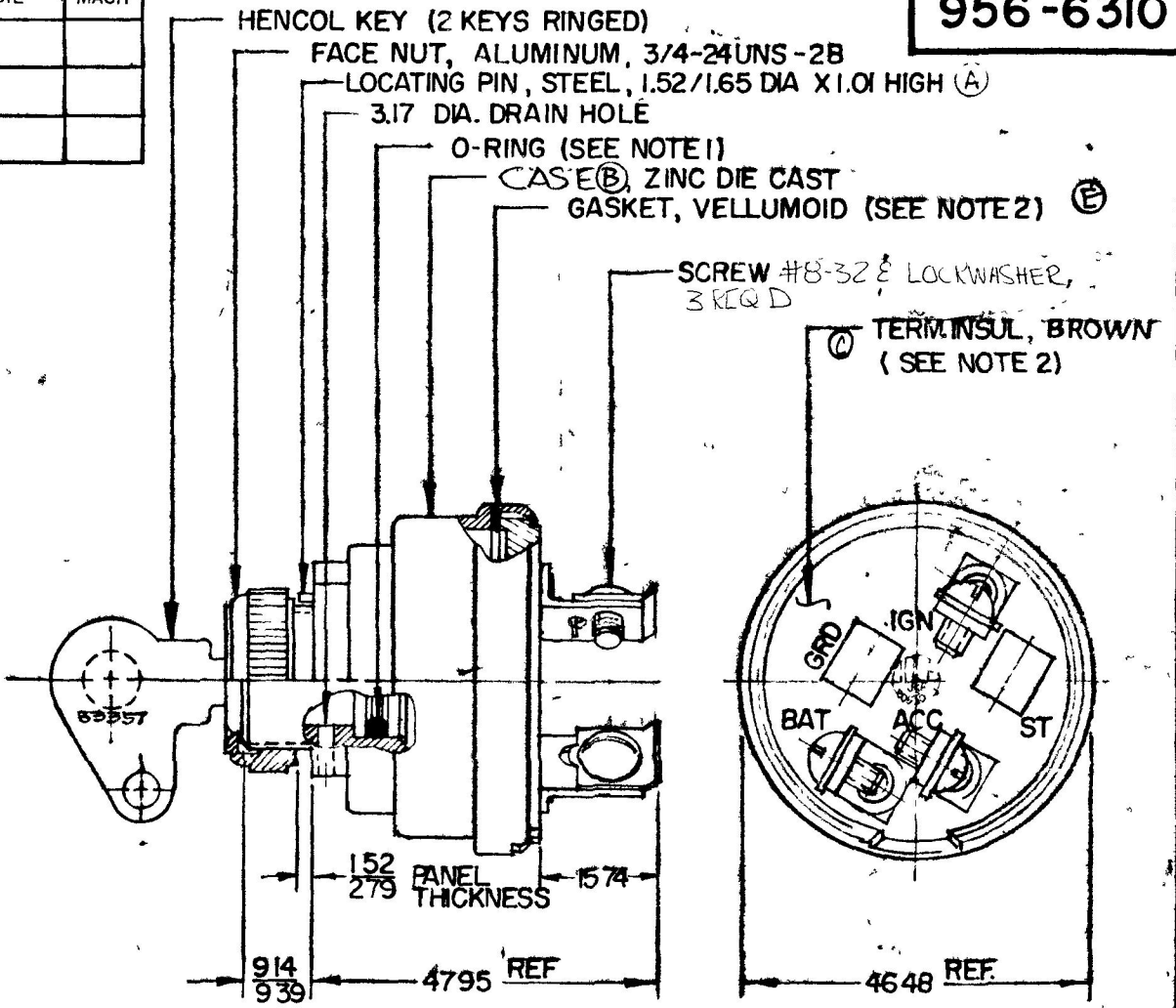

- NOTE:**
1. SHAFT O-RING SEALED TO CASE
  2. TERM INSUL GASKET SEALED
  3. COPPER RIVETS ON MOVABLE CONTACT
  4. ALL STEEL PARTS PLATED

LET	WAS	DATE	BY	LET	WAS	DATE	BY	MATERIAL	DRAWN	CHECKED	APPRVD	SCALE	956-6310 W/ PIN, FIBER TE INSUL & COPPER RIVETS ON CONTACT	DO NOT SCALE
				D	ZINC 126234	12/18/92	TJH	—	RMT	5-23-79		1:1		DATE DRAWN 3-12-79
				C	ECN 25189	8-14-92	TJH	FINISH	<b>COLE-HERSEE COMPANY</b> BOSTON, MASS 02127, U.S.A.					DATE BLUEPRINT
				B	HOUSING	8/1/82	PB	—						
				A	REV 20702	9-12-79	JV	TOLERANCES FRACTIONAL ± DECIMAL ±.25	<b>ACC - IGNITION SWITCH</b>					<b>956-6310</b>
E	ECN #00139	3/1/00	NF		ISSUED	6-1-19	Y							

SPAULDING CO., INC