

Impulse Noise Benefits of Line Card Access Switches

1. Introduction

As the telephony cable in the “last mile” becomes used for services other than analog voice communication, issues concerning the generation of impulse noise become more important. These other services such as analog modems and various DSL offerings are much more susceptible to impulse noise produced by the analog voice interfaces. A set of impulse noise requirements is specified in Telcordia technical requirement TR-NWT-000057, *Functional Criteria for Digital Loop Carrier (DLC) Systems Analog Transmission Criteria*, Jan. 1993, Section 6.1.

The impulse noise coupling mechanism is primarily a near-end phenomena, due to the capacitive nature of the telephone cable, and may couple from other pairs in the cable, from adjacent circuits on a line card, from inadequate voltage regulation, and from common-mode ground noise. All of these coupling mechanisms are reduced when the tip and ring switching voltages and currents are not allowed to change abruptly. The actual quantifying of the impulse noise is extremely difficult due to the coupling mechanisms. This application note addresses design practices that minimize the impulse noise produced from analog line cards.

2. Analog Line Card Design

2.1 History

The analog line card provides an interface to one or more standard analog telephones, analog modems, analog answering machines, or ancillary equipment that would plug into a conventional telephone jack. The line card needs to provide battery feed current, ringing, forward disconnect, and the ability to detect on- and off-hook conditions at the end equipment. Over time these features became known as the BORSCHT functions, in order to fully support the equipment that the customer plugs into phone jacks. The BORSCHT functions are:

- B:** Battery feed
- O:** Over-voltage protection
- R:** Ringing
- S:** Supervision
- C:** Coding from analog to digital and digital to analog
- H:** Hybrid and signal conditioning
- T:** Test

The early line cards did not perform the coding function since the network was analog and the test function was generally used on high usage trunk circuits.

The ringing signal, which is usually 20Hz AC, 86 V_{RMS} , was not efficient and economical to generate for each circuit and was centrally generated, fused, and bussed to the line cards. Large flat spring electro-mechanical relays (EMRs) handled the switching of these voltages and the line cards had the capacity to only handle a few circuits. The line cards were located in the telephone central office where maintenance and troubleshooting tasks were performed by on site personnel. The centralization of the line cards, the cost and space of the relays, and the cost of on-site personnel resulted in cards with few testing and troubleshooting features. Additionally troubleshooting via the plug and unplug approach was not too invasive in an all-voice environment with short call hold times and only a few circuits per line card.

2.2 Present

Years ago, the analog telephone network was replaced by the digital network with all line card interfaces containing coding and decoding functions (CODECs). The remaining BORSCHT functions were done with discrete circuitry and relays. Later the SLIC (subscriber line interface circuit) was designed as a solid state replacement for many of the BORSCHT functions that were done discretely. Much smaller relays were also designed and many more circuits were able to fit on a single line card. The use of phone lines for data resulted in the need for more circuits, and, in most cases, an insufficient number of wires from the customer to the telephone company. Existing wires were reused as T1 lines (optical fiber more recently) to remote cabinets which contained the line cards that connected to the customer's location. This decentralization of equipment has resulted in the need for much better testing and troubleshooting capabilities in the line cards. Problems need to be diagnosed

as being in the central office, in the interface to the remote cabinet, in the remote cabinet, in the wire to the customer location, or at the customer location. These increased test requirements, and the fact that even the newest SLICs still do not completely implement all the BORSCHT functions for many systems, play to the strengths of the line card access switch (LCAS). The use of a SLIC may result in compromises for the battery feed, ringing, test, and over-voltage functions as detailed below.

- SLIC Battery Feed Function.** The voltage and current provided for the longest telephone loops (TR-NWT-000057) may be inadequate due to the voltage overhead that the SLIC imposes. The longest loops are slightly over 1800 ohms (900 ohms for each tip and ring). At least 23 mA must be supplied for telephone devices to operate properly. For short loop applications (TR-NWT-000909) the SLIC is completely satisfactory for battery feed. The battery feed characteristics of SLICs have been improving.
- SLIC Ringing Function.** The ringing signal provided by the central office is approximately an 86 V_{RMS} , 20 Hz AC near-sinusoidal waveform, superimposed on top of the -48V DC battery feed as shown below. This is the ringing standard, and all telephone devices will detect this signal. Actually, since the resistance in the loop attenuates this ringing signal, station devices are required to detect this signal if the AC value is as low as 40 V_{RMS} , and will typically detect voltages much lower, but the alerting signal will be at reduced volume.

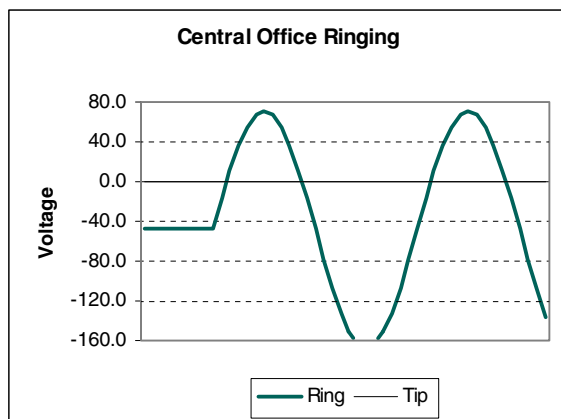

SLICs are unable to provide a ringing signal with a range from +70 V to -165 V. The two most common compromise methods of SLIC ringing are reduced amplitude trapezoidal and symmetrical ringing.

Trapezoidal ringing generally has an RMS amplitude of less than 50V even with crest factors of 1.2, which

is the minimum allowed. The crest factor is the ratio of peak voltage to RMS voltage after the DC has been removed (sinusoidal waveforms have crest factors of 1.41 and square waves have crest factors of 1.0). Lower crest factors have larger RMS values for a given voltage swing. TR-NWT-000057 requires crest factors to be between 1.2 and 1.6. While trapezoidal ringing maintains the underlying -48V DC bias, the ringing amplitude is generally only useful for reduced loop length designs. Attempts to reduce the crest factor in order to squeeze out a little more voltage trigger some devices into thinking that the line is not ringing but has large-amplitude rotary dialing.

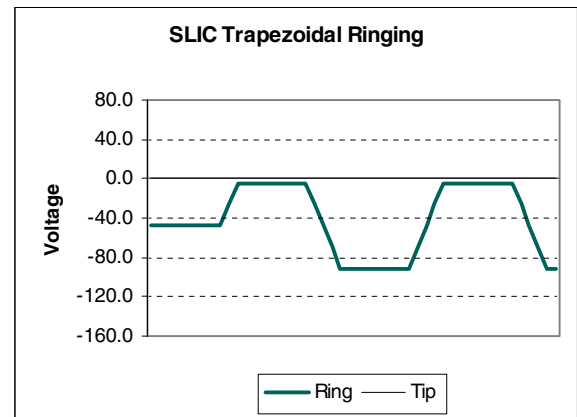

Symmetrical ringing provides a much larger amplitude RMS ringing voltage but reduces the DC bias voltage to zero. This signal is capable of ringing a full length line but many devices, particularly answer machines, refuse to detect this type of ringing. Often some type of trapezoidal and symmetrical ringing combination is used where the ringing voltage may be 65 V_{RMS} and the bias voltage is -20 Vdc. However, AT&T and Casio made answering machines that needed the standard ringing and bias voltages to detect an incoming call.

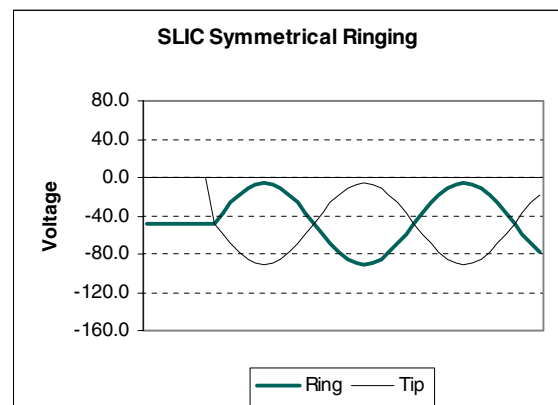

Consequently many applications can not use the SLIC to provide ringing directly and will need an external relay to provide the ringing from a common ringing source.

- **SLIC Test Function.** The SLIC may provide some outputs to drive external relays for the testing functions, which may be required. Additional testability is becoming more important as the line cards have larger number of interfaces and the cost of maintenance rises.
- **SLIC Overvoltage Protection.** The SLIC only provides tertiary over-voltage protection. Line cards needing to meet Telcordia GR-1089 product safety requirements will need secondary protection in the form of some low value resistors combined with fuses and sidactors.
- **Test Access.** SLICs may contain logic to drive electro-mechanical relays (EMRs) for test purposes but do not provide the actual switching.

The above limitations do not disqualify the use of SLICs. The supervision and hybrid functions are presently done extremely well and cost effectively by the SLIC. The line card access switch (LCAS) is directly aimed at supplementing the features of the SLIC that are not provided, or not provided well. The included secondary over-voltage protection for the SLIC can be positioned to protect both the SLIC and the LCAS.

The additional switching features that the LCAS provides decrease the required printed circuit board space and cost compared to an EMR implementation.

3. Creation of Impulse Noise

The previous section on line card design did not address the creation of impulse noise, which is produced when the tip and ring voltages and currents are changed abruptly. Impulse noise may affect other circuits in the same cable, on the same line card, or, in very bad cases, even on adjacent cables and boards. The impulse noise may be a click or pop on an analog voice connection but may result in data errors or total loss of data transmission in a digital circuit. While section 6.1 of TR-NWT-000057 details the criteria for making the impulse noise tests, the model for the coupling mechanism is extremely difficult to determine and consequently the tests are very hard to quantify.

The remainder of the application note will discuss techniques to minimize the abrupt voltage and current

changes that occur on the tip and ring, and, to a lesser extent, on the line card itself.

The primary causes of impulse noise in order of concern are:

1. Application and removal of ringing from the line. This is definitely the most frequent event and involves the largest voltages. Additionally the ringing load itself can contribute to the impulse noise.
2. Application and removal of the battery feed to signal a forward disconnect.
3. Switching of the test functions. These actions occur very infrequently and involve voltages similar to the above actions and therefore have similar solutions.

3.1 Ringing Loads

Historically, the ringer in a telephone was an inductive type device consisting of a coil applying a magnetic force to a clapper that struck against a bell. This circuit needed a DC blocking capacitor and the value of the capacitor was chosen to make the circuit resonant slightly above 20Hz. The impedance of this circuit, including the resistance in the wire, was approximately 7000 ohms. This load became known as 1 REN (ringer equivalence). The inductance in the coil varied due to the change in the magnetic path produced by the moving clapper. A line circuit is expected to be able to ring 5 standard phones or 5 REN.

Most newer phones contain tone type ringers and the ringing load is a capacitor and resistance in series. Diodes and other components are present but do not affect the understanding of the impulse noise. Again the notion of REN exists where an impedance of 7000 ohms at the ringing frequency is 1 REN. All telephones have the REN value printed on the bottom of the phone.

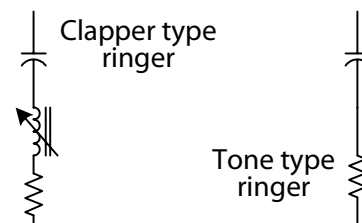

3.2 Application of Ringing

The application and removal of large voltages to the ringing loads can cause large noise transients, as the following graphs show. The connection may be done with electro-mechanical relays (EMRs) or via SCRs, TRIACs, FETs or any other solid state mechanism.

The LCAS uses a combination of SCRs and FETs for the switches.

The voltage at the ringing input relative to the ring lead at the instant when switching occurs has a direct effect on the produced impulse noise. Also the contacts in EMRs generally bounce open and closed for a fraction of a millisecond. As a result, EMR circuits often contain some "contact protection circuitry" which is included more for impulse noise reduction than actual contact protection of the relay. However, this adds cost and space to EMR based designs.

The following circuit shows the switching occurring only on the ring lead. In practice both the tip and ring leads are switched in order to separate the ringing return current from the battery feed current. However, switching only the ring lead is sufficient to show the effect on the produced impulse noise. The circled numbers refer to oscilloscope traces in the later figures.

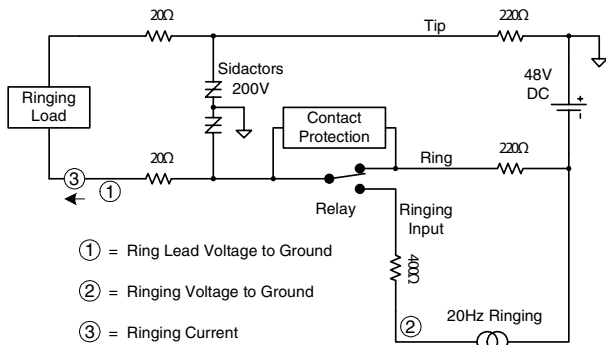

The following circuits show two ringing loads used for the tests. The ringing load on the left, while containing both inductive and capacitive components, appears to be inductive for frequencies much above 20 Hz.

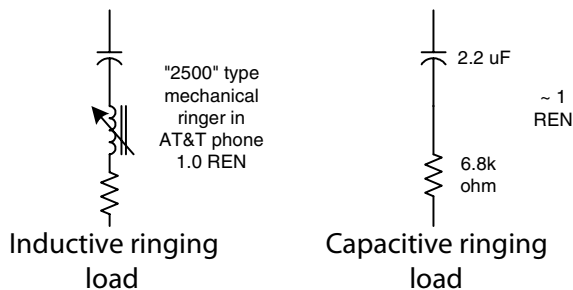

The table shows the results of the application and removal of ringing to different ringing loads at various phases of ringing. A phase of 0 degrees is the ringing AC voltage = 0V, 90 degrees is a maximum positive AC ringing voltage, 270 degrees is a maximum negative AC ringing voltage etc. In all cases, the quicker

the connection is opened or closed the more impulse noise is produced. The contact protection network tries to reduce this sudden change, as do the slow make and break times within the LCAS.

Condition	Ringing Load Type	Ringing Phase	Impulse Noise
Applying Ringing		0 or 180 degrees	very low
		Random	low
Removing Ringing	Inductive	0 or 180 degrees (depends on current flow)	?
		near 0 or 180 degrees (see note below)	low
		90 or 270 degrees	very high
		random	high
Applying Ringing	Capacitive	0 or 180 degrees	very low
		90 or 270 degrees	high
Removing Ringing	Capacitive	random	moderate
		0 or 180 degrees	very low
		random	moderate

Note: A series RLC circuit at resonance will have the voltage and current in phase. However, the inductance in the ringer is non-linear and several measured ringers had slightly different non-zero phase relationships between the voltage and current. Therefore, predicting the zero current time is extremely difficult to do.

As the table shows (and the following data illustrates), the best conditions are to apply ringing at the zero crossing of the ringing voltage (phase of 0 or 180 degrees). Removal of ringing is likewise best near zero crossing. However, the line card is not aware of the ringing load and consequently must handle both inductive and capacitive loads. Contact protection or semiconductor devices such as LCAS that limit the abrupt switching help greatly. The single most difficult condition that produces impulse noise is the removal of ringing from an inductive load.

4. Tests

All the tests were done on “zero ohm” loops since shorter loops allow the voltages and currents to change more quickly. The circuits are minimal and

only include components necessary to show the generated waveforms that would cause the impulse noise.

4.1 Removal of Ringing to an Inductive Load via EMR (Relays)

Very bad impulse noise:

250V spike, $dv/dt = 70V/\mu\text{sec}$. @ 12mA of ring current

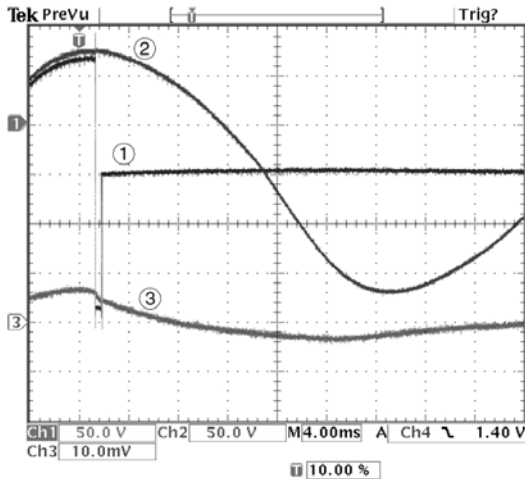

Figure EMR1: Removal of ringing, inductive load, no contact protection, Phase = 90 deg.

Bad impulse noise:

120V spike, $dv/dt = 30V/\mu\text{sec}$. @ 12mA of ring current

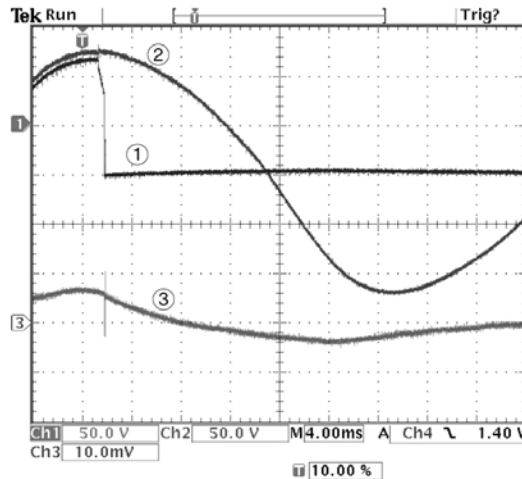

Figure EMR2: Same as Fig. EMR1 with contact protection

- ① = ring lead voltage to ground
- ② = ringing input voltage to ground
- ③ = 20mA/div. (ring lead current)

Bad impulse noise:

140V spike, $dv/dt = 60V/\mu\text{sec}$. @ 4mA of ring current

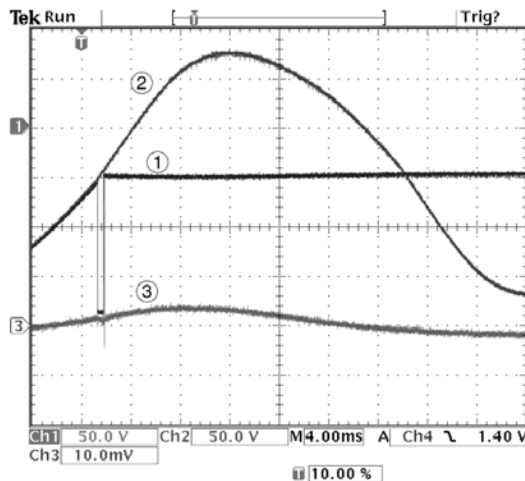

Figure EMR3: Removal of ringing, inductive load, no contact protection, Phase = 0 deg.

Low impulse noise:

20V spike, $dv/dt = 1V/\mu\text{sec}$. @ 4mA of ring current

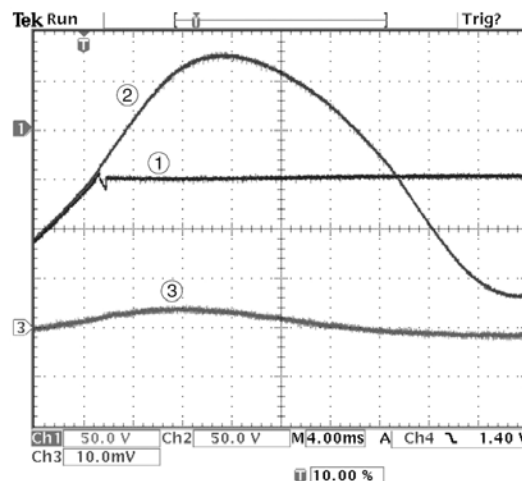

Figure EMR4: Same as Fig. EMR3 with contact protection

4.2 Application of Ringing via EMRs (Relays)

Very low impulse noise:

No spike, $dv/dt < .1V/usec.$ @ 0mA of ring current

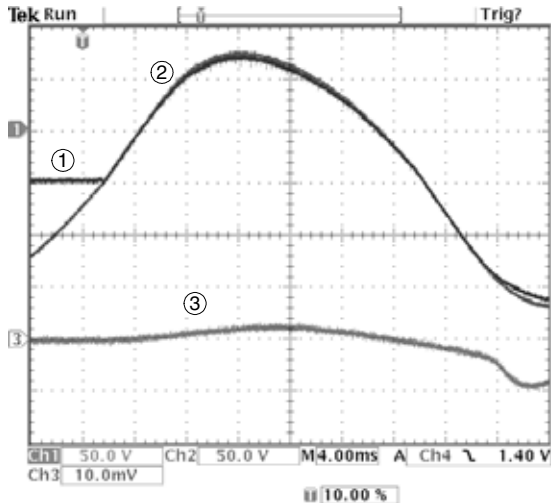

Figure EMR5: Application of ringing, inductive load, no contact protection, Phase = 0 deg.

Very low impulse noise:

No spike, $dv/dt < .1V/usec.$ @ 0mA of ring current

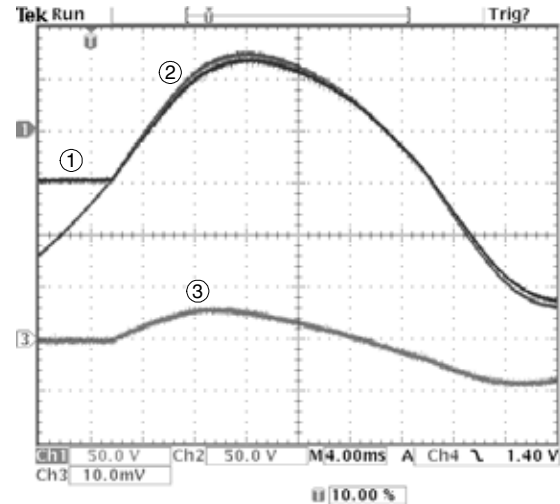

Figure EMR6: Application of ringing, capacitive load, no contact protection, Phase = 0 deg.

- ① = ring lead voltage to ground
- ② = ringing input voltage to ground
- ③ = 20mA/div. (ring lead current)

The previous graphs show that impulse noise behavior associated with EMR designs is highly variable and unpredictable. To reduce impulse noise, designers must use contact protection and make the switching occur at the zero crossing point. However, this adds cost and space to these designs. Careful consideration of the operate and release times of the relays used must be accounted for in this calculation.

No graphs were shown for using EMRs for the line break function and test access. The line break function needs minimal contact protection and no contact protection would be needed for the test access functions due to the fact that these tests run so infrequently.

5. Using LCAS in an Analog Line Card Design

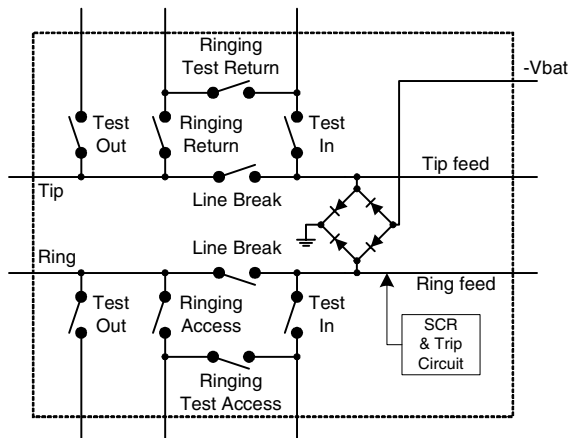

The basic block diagram of the LCAS is shown above with the “ringing test” switches only in the CPC7583BC and CPC7583BD parts. The switches are configured as FETs with the exception of the “ringing access” and “ringing test” switches, which are pnpn latching-type devices. All the switches close as pairs, but the pnpn switches only open when the current through them is near zero. Consequently the LCAS design operates differently than an EMR design.

The FET switches in the LCAS operate and release slowly (less than 1 msec.) which acts to reduce the generated impulse noise. These switches all operate similarly so graphs are only shown for the line break and make function.

Furthermore, the LCAS has two operational modes to consider when removing ringing. These modes are make-before-break (MBB) and break-before-make (BBM). See “Comparison between MBB and BBM operation” on page 13 for more information.

6. Using LCAS to Make and Break the Line

The following schematic shows the circuit used to perform the line make and break tests. Note that the battery feed resistors have a high value. These resistors were chosen to be higher than would be used in an actual design since a SLIC would limit the loop current for short loops. The resistors were set to give a loop current of 36 mA with a 300 ohm resistor simulat-

ing the telephone. Figures LCAS1 and LCAS2 show the closing and opening of the break switches.

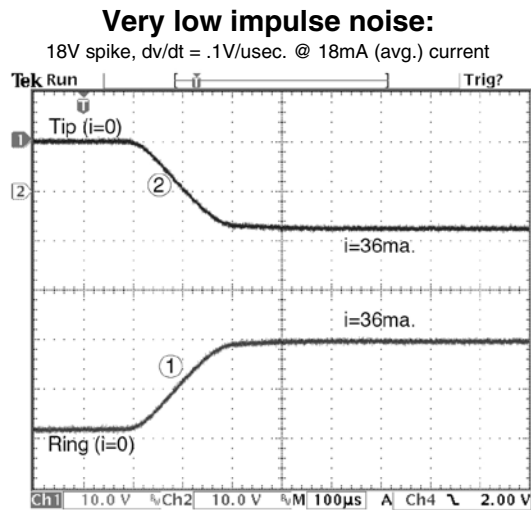
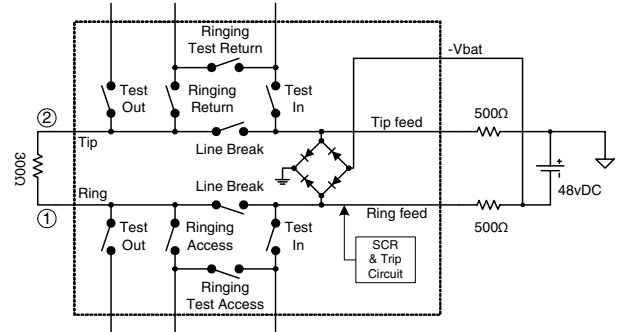

Figure LCAS1: Closing the line break switches

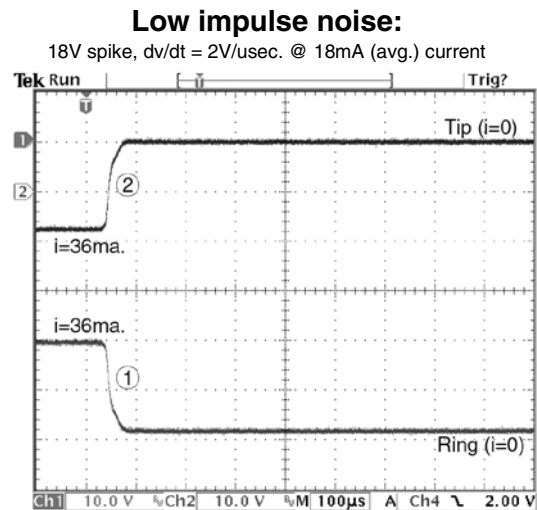

Figure LCAS2: Opening the line break switches

- ① = ring lead voltage to ground
- ② = tip lead voltage to ground

7. Using LCAS to Apply and Remove Ringing

The following schematic shows the circuit used to perform the application and removal of ringing tests. See “Comparison between MBB and BBM operation” on

page 13 for details concerning why make-before-break operation was chosen, and some of the details to consider.

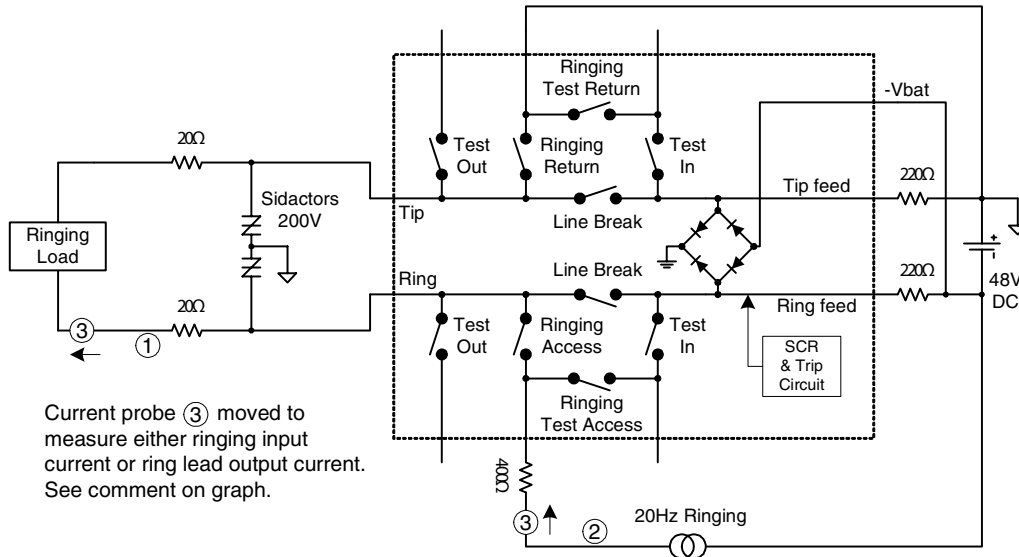

8. Removal of Ringing via LCAS (Make-Before-Break Mode)

Very low impulse noise:

25V spike, $dv/dt = .2V/\mu\text{sec}$. @ 2mA (avg.) current

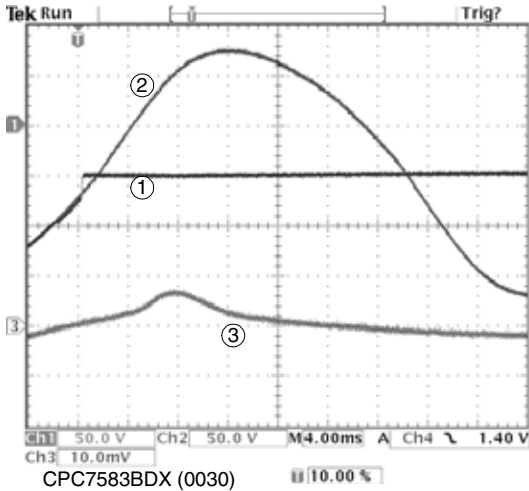

Figure LCAS3: Removal of ringing, inductive load, slightly before positive zero crossing

Very low impulse noise:

25V spike, $dv/dt = .5V/\mu\text{sec}$. @ -2mA (avg.) current

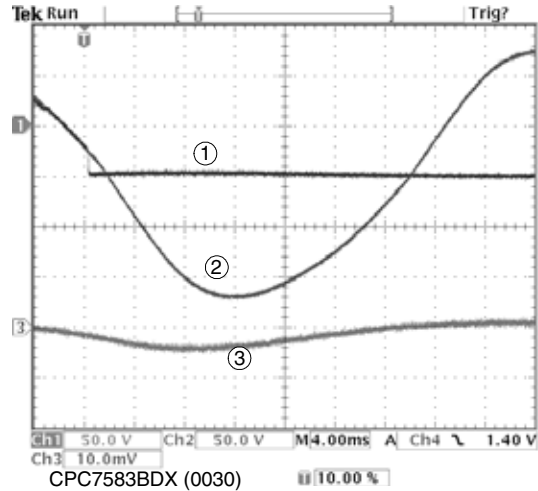

Figure LCAS4: Removal of ringing, inductive load, slightly before negative zero crossing

- ① = ring lead voltage to ground
- ② = ringing input voltage to ground
- ③ = 20mA/div. (ring lead current)

Very low impulse noise:

25V spike, $dv/dt = .2V/\mu\text{sec}$. @ 3mA (avg.) current

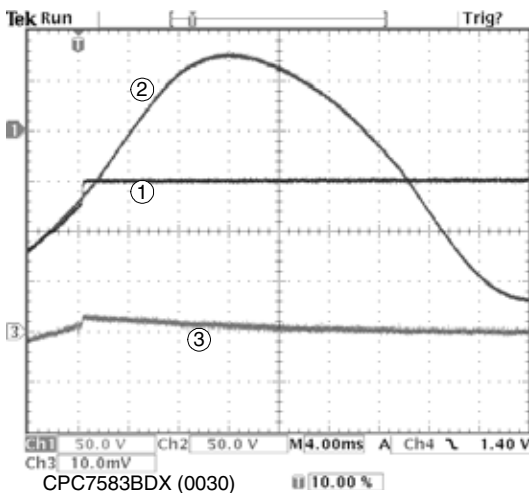

Figure LCAS5: Removal of ringing, capacitive load, slightly before positive zero crossing

Very low impulse noise:

25V spike, $dv/dt = .5V/\mu\text{sec}$. @ -2mA (avg.) current

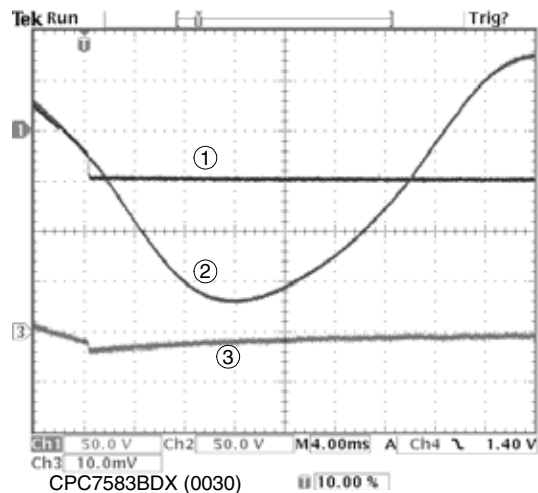

Figure LCAS6: Removal of ringing, capacitive load, slightly before negative zero crossing

Removal of ringing was done slightly before zero crossing to insure that the pnpn ringing switch did not become latched for $\frac{1}{2}$ cycle of the ringing causing high input ringing current. See "Comparison between MBB and BBM operation" on page 13 for more information.

9. Application of Ringing via LCAS

Very low impulse noise:

25V spike, $dv/dt = 5V/\mu\text{sec}$. @ 0mA (avg.) current

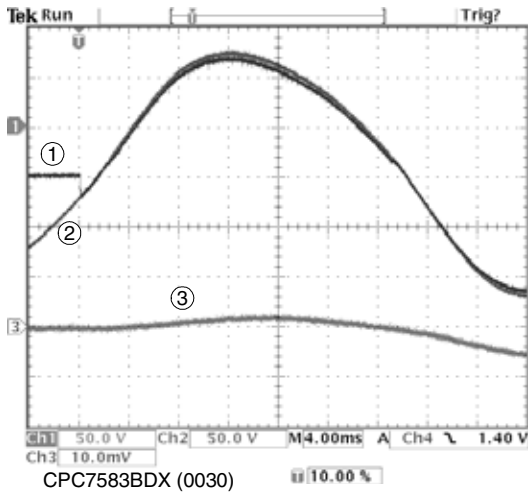

Figure LCAS7: Application of ringing, inductive load, slightly before positive zero crossing

Very low impulse noise:

25V spike, $dv/dt = 1V/\mu\text{sec}$. @ 0mA (avg.) current

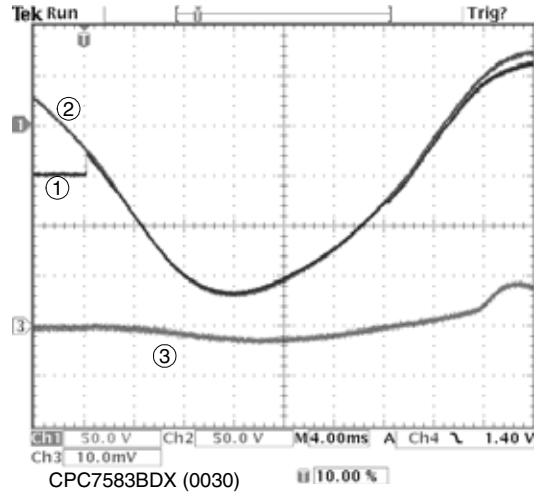

Figure LCAS8: Application of ringing, inductive load, slightly before negative zero crossing

- ① = ring lead voltage to ground
- ② = ringing input voltage to ground
- ③ = 20mA/div. (ring lead current)

Low impulse noise:

25V spike, $dv/dt = 10V/\mu\text{sec}$. @ 1mA (avg.) current

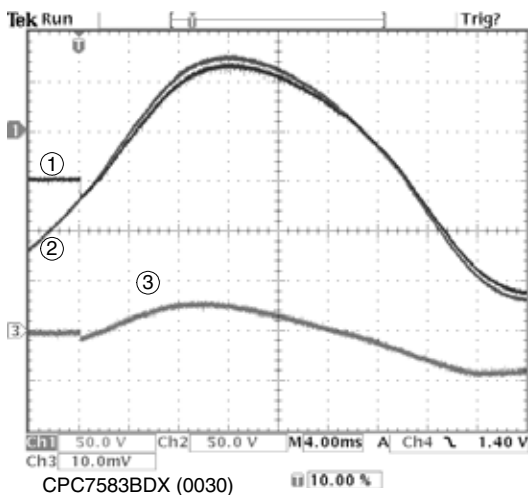

Figure LCAS9: Application of ringing, capacitive load, slightly before positive zero crossing

Low impulse noise:

25V spike, $dv/dt = 10V/\mu\text{sec}$. @ -1mA (avg.) current

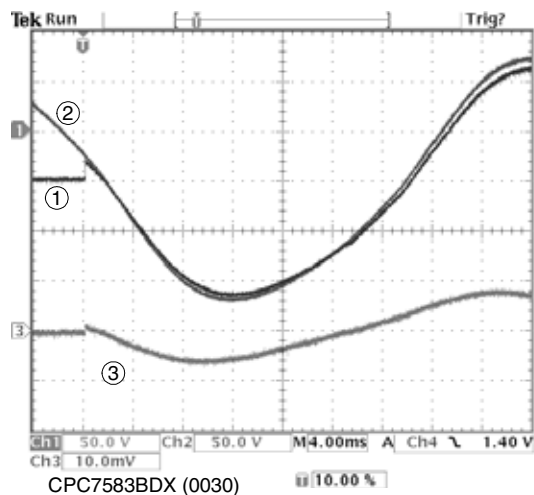

Figure LCAS10: Application of ringing, capacitive load, slightly before negative zero crossing

Application of ringing was done slightly before zero crossing to be consistent with the timing for the removal of ringing. This time may be the actual zero crossing time for the generation of even less impulse noise for capacitive loads.

10. Comparison between MBB and BBM operation

The make-before-break (MBB) and break-before-make (BBM) operations of the LCAS refer to the timing of the line break switches, the ringing access switch, and the ringing return switch when transitioning from the ringing state to the battery feed state.

The BBM mode opens the ringing return FET switch slowly while the line break switches remain open. The ringing access switch automatically opens when the current through it drops to nearly zero. Then the load is disconnected from the LCAS until the line break switches are instructed to close. The rate at which the ringing return switch opens the current flowing to the load that is being rung and the type of ringing load determine the magnitude of the produced impulse noise. Switching near the zero crossing of the ringing voltage will generally be the best time to remove ringing for the BBM mode.

The MBB mode closes the line break switches before the ringing return FET switch opens. The rate at which the ringing return FET opens is of little consequence due to the shunting by the line break switch in the tip lead. Similar to the BBM mode, the ringing access switch automatically opens when the current through it drops to nearly zero. However, there is now a path for the ringing current to flow back through the line break switch in the ring lead into the SLIC. While there will generally not be much impulse noise produced on the line, the ringing current flowing back through the SLIC represents a ringing load and may couple into the battery feed for other circuits on the line card. Switching slightly before the zero crossing of the ringing voltage will be the best time to remove ringing and will result in a small current flowing into the SLIC.

10.1 Other TR-57 issues

TR-57 has a requirement that the ringing signal be reproduced within +/- 50 msec. Applying and removing ringing near the zero crossing could potentially produce a +/- 25msec. error in the duration of the ringing signal.

11. Conclusion: EMR versus LCAS design

The previous results show the advantages and predictability of using LCAS for impulse noise reduction. In addition, because it is a silicon device, the turn-on and turn-off times of the switches can be optimized in future designs for even better performance. EMR designs require additional contact protection networks to reduce impulse noise. This adds cost and space and even then does not approach the impulse noise performance achieved by LCAS.

While the EMR solution may be technically acceptable for certain applications, the requirements for test in and test out access leads to the total requirement of 3

to 5 relays per circuit plus at least two noise reduction networks. The noise reduction networks need capacitors with voltage ratings of 250V in order to pass the GR-1089 tests. The resulting printed circuit board space for the EMR design will be at least 50% greater than the LCAS design due to the fact that the components all need to be on the top of the of the PCB due to their height. This may force the designer into a decision between a 32-channel LCAS line card design or a 16 channel EMR line card design. For a design in a remote cabinet where space is quite precious the decision would be an easy one.

12. Clare, Inc. Design Resources

www.ixysic.com has a wealth of information useful for designing with Clare products, including application notes and reference designs that meet all applicable regulatory requirements. Product data sheets also contain additional application and design information. See the following links:

- [CPC7851 Data Sheet](#)
- [CPC7582 Data Sheet](#)
- [CPC7583 Data Sheet](#)
- IXYS IC Division app note AN-100, [Designing Surge and Power Fault Protection Circuits for Solid-State Subscriber-Line Interfaces](#)

12.1 Third Party Design Resources

The following also contain information useful for LCAS designs. All of the books are available on amazon.com.

Understanding Telephone Electronics, Stephen J. Bigelow, et. al., Butterworth-Heinemann; ISBN: 0750671750

Newton's Telecom Dictionary, Harry Newton, CMP Books; ISBN: 1578200695

United States Code of Federal Regulations, CFR 47 Part 68.3

For additional information please visit our website at: www.ixysic.com

IXYS Integrated Circuits Division makes no representations or warranties with respect to the accuracy or completeness of the contents of this publication and reserves the right to make changes to specifications and product descriptions at any time without notice. Neither circuit patent licenses nor indemnity are expressed or implied. Except as set forth in IXYS Integrated Circuits Division's Standard Terms and Conditions of Sale, IXYS Integrated Circuits Division assumes no liability whatsoever, and disclaims any express or implied warranty, relating to its products including, but not limited to, the implied warranty of merchantability, fitness for a particular purpose, or infringement of any intellectual property right.

The products described in this document are not designed, intended, authorized or warranted for use as components in systems intended for surgical implant into the body, or in other applications intended to support or sustain life, or where malfunction of IXYS Integrated Circuits Division's product may result in direct physical harm, injury, or death to a person or severe property or environmental damage. IXYS Integrated Circuits Division reserves the right to discontinue or make changes to its products at any time without notice.

Specification: AN-144-R02
©Copyright 2014, IXYS Integrated Circuits Division
All rights reserved. Printed in USA.
4/11/2014