

## Braking Rectifier Assemblies

Typ	Typical			Max.			
	$V_{vRMS}$ V	$V_{dAV}$ V	$I_{dAVM}$ A	$I_{dAVM}$ A	$V_{RRM}$ V	$I_{FSM}$ A	$I^2t$ A <sup>2</sup> s
VGB 0124 AY7a	380	340	1.0	1.0	1400	60	28

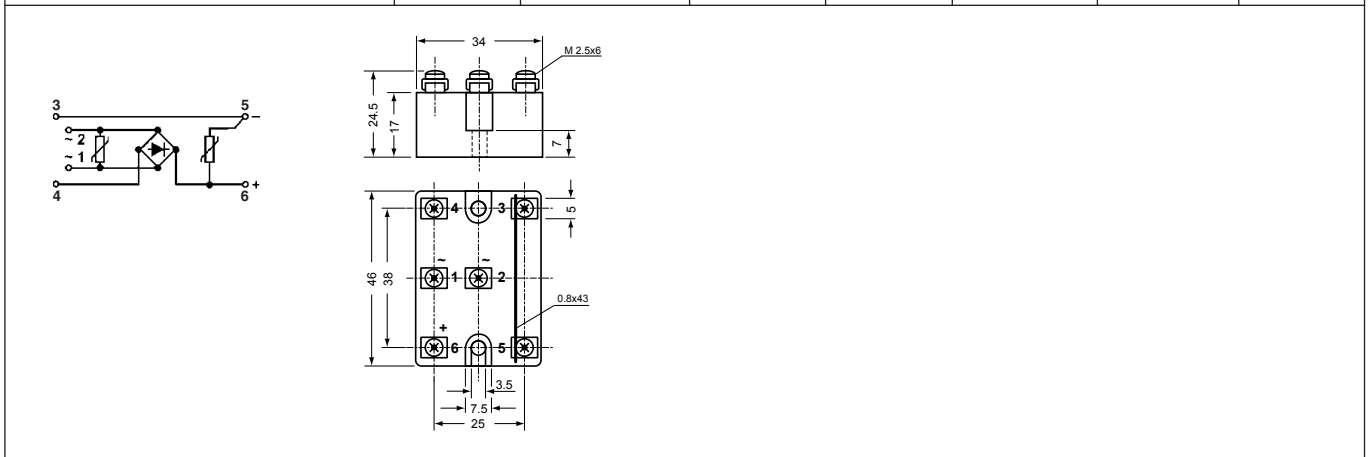

Typ	Typical			Max.			
	$V_{vRMS}$ V	$V_{dAV}$ V	$I_{dAVM}$ A	$I_{dAVM}$ A	$V_{RRM}$ V	$I_{FSM}$ A	$I^2t$ A <sup>2</sup> s
VGf 0136 AB	1000	440	1.2	1.5	2800	80	40

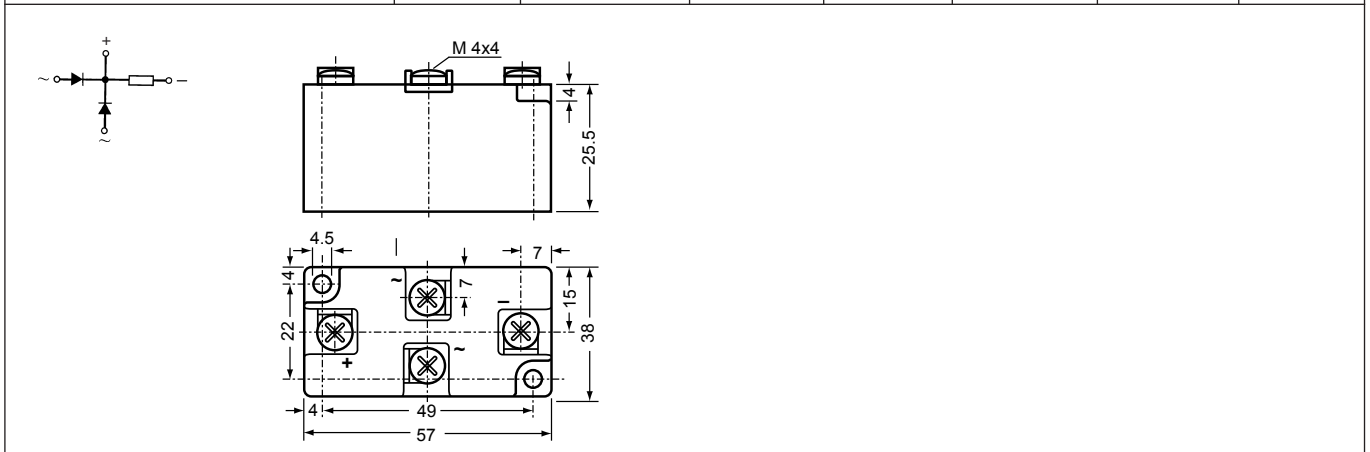

Data according to IEC 60747

### Disclaimer Notice

Information furnished is believed to be accurate and reliable. However, users should independently evaluate the suitability of and test each product selected for their own applications. Littelfuse products are not designed for, and may not be used in, all applications. Read complete Disclaimer Notice Disclaimer Notice at [www.littelfuse.com/disclaimer-electronics](http://www.littelfuse.com/disclaimer-electronics).

IXYS reserves the right to change limits, test conditions and dimensions