

# MCR08B, MCR08M

## Surface Mount – 600V - 800V

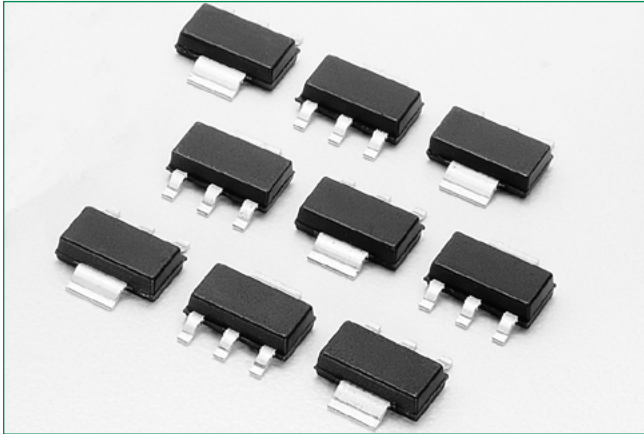

### Description

PNPN devices designed for line powered consumer applications such as relay and lamp drivers, small motor controls, gate drivers for larger thyristors, and sensing and detection circuits. Supplied in surface mount package for use in automated manufacturing.

### Features

- Sensitive Gate Trigger Current
- Blocking Voltage to 600 V
- Glass Passivated Surface for Reliability and Uniformity
- Surface Mount Package
- Lead-free and RoHS-compliant

### Functional Diagram

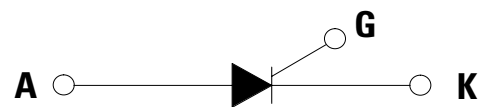

### Pin Out

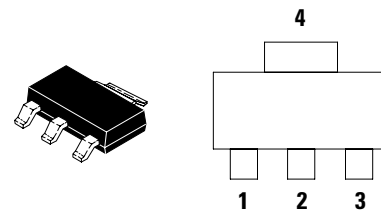

### Additional Information



Resources



Accessories



Samples

# MCR08B, MCR08M

## Surface Mount – 600V - 800V

### Maximum Ratings ( $T_J = 25^\circ\text{C}$ unless otherwise noted)

Rating	Symbol	Value	Unit
Peak Repetitive Off-State Voltage (Note 1) (Sine Wave, $R_{GK}=1\text{ k}\Omega$ , $T_J = 25$ to $110^\circ\text{C}$ )	$V_{DRM}$ $V_{RRM}$	200 600	V
On-State RMS Current (All Conduction Angles; $T_C = 80^\circ\text{C}$ )	$I_{T(RMS)}$	0.8	A
Peak Non-Repetitive Surge Current (1/2 Cycle Sine Wave, 60 Hz, $T_C = 25^\circ\text{C}$ )	$I_{TSM}$	8.0	A
Circuit Fusing Consideration ( $t = 8.3\text{ ms}$ )	$I^2t$	0.4	$\text{A}^2\text{sec}$
Forward Peak Gate Power ( $T_C = 80^\circ\text{C}$ , $t = 1.0\ \mu\text{s}$ )	$P_{GM}$	0.1	W
Average Gate Power ( $t = 8.3\text{ ms}$ , $T_C = 80^\circ\text{C}$ )	$P_{GM(AV)}$	0.01	W
Operating Junction Temperature Range	$T_J$	-40 to +110	$^\circ\text{C}$
Storage Temperature Range	$T_{stg}$	-40 to +150	$^\circ\text{C}$

### Thermal Characteristics

Rating	Symbol	Value	Unit
Thermal Resistance, Junction-to-Ambient PCB Mounted per Figure 1	$R_{\theta JA}$	156	$^\circ\text{C/W}$
Thermal Resistance, Junction-to-Tab Measured on Anode Tab Adjacent to Epoxy	$R_{\theta JA}$	25	$^\circ\text{C/W}$
Maximum Device Temperature for Soldering Purposes (for 10 Seconds Maximum)	$T_L$	260	$^\circ\text{C}$

Stresses exceeding Maximum Ratings may damage the device. Maximum Ratings are stress ratings only. Functional operation above the Recommended Operating Conditions is not implied. Extended exposure to stresses above the Recommended Operating Conditions may affect device reliability.

1.  $V_{DRM}$  and  $V_{RRM}$  for all types can be applied on a continuous basis. Ratings apply for zero or negative gate voltage; however, positive gate voltage shall not be applied concurrent with negative potential on the anode. Blocking voltages shall not be tested with a constant current source such that the voltage ratings of the devices are exceeded.

### Electrical Characteristics - OFF ( $T_J = 25^\circ\text{C}$ unless otherwise noted ; Electricals apply in both directions)

Characteristic	Symbol	Min	Typ	Max	Unit
Peak Repetitive Forward or Reverse Blocking Current (Note 3) ( $V_{AK} = \text{Rated } V_{DRM} \text{ or } V_{RRM}$ , $R_{GK} = 1\text{ k}\Omega$ )	$I_{DRM}$	-	-	10	$\mu\text{A}$
	$I_{RRM}$	-	-	200	$\mu\text{A}$

### Electrical Characteristics - ON ( $T_J = 25^\circ\text{C}$ unless otherwise noted; Electricals apply in both directions)

Characteristic	Symbol	Min	Typ	Max	Unit
Peak Forward On-State Voltage (Note 2) ( $I_T = 1.0\text{ A Peak}$ )	$V_{TM}$	-	-	1.7	V
Gate Trigger Current (Continuous dc) (Note 4) ( $V_{AK} = 12\text{ Vdc}$ , $R_L = 100\ \Omega$ )	$I_{GT}$	-	-	200	$\mu\text{A}$
Holding Current (Note 3) ( $V_{AK} = 12\text{ Vdc}$ , Initiating Current = 20 mA)	$I_H$	-	-	5.0	mA
Gate Trigger Voltage (Continuous dc) ( $V_D = 12\text{ V}$ , $R_L = 100\ \Omega$ )	$V_{GT}$	-	-	0.8	V
Turn-On Time ( $V_{AK} = 12\text{ Vdc}$ , $I_{TM} = 5\text{ Adc}$ , $I_{GT} = 5\text{ mA}$ )	$t_{gt}$	-	1.25	-	$\mu\text{s}$

2. Pulse Test: Pulse Width  $\leq 300\ \mu\text{s}$ , Duty Cycle  $\leq 2\%$ .

3.  $R_{GK} = 1000\ \Omega$  is included in measurement.

4.  $R_{GK}$  is not included in measurement.

### Dynamic Characteristics

Characteristic	Symbol	Min	Typ	Max	Unit
Critical Rate-of-Rise of Off State Voltage ( $V_{pk} = \text{Rated } V_{DRM}$ , $T_C = 110^\circ\text{C}$ , $R_{GK} = 1\text{ k}\Omega$ , Exponential Method)	$dv/dt$	10	-	-	$\text{V}/\mu\text{s}$

# MCR08B, MCR08M

Surface Mount – 600V - 800V

## Voltage Current Characteristic of SCR

Symbol	Parameter
$V_{DRM}$	Peak Repetitive Forward Off State Voltage
$I_{DRM}$	Peak Forward Blocking Current
$V_{RRM}$	Peak Repetitive Reverse Off State Voltage
$I_{RRM}$	Peak Reverse Blocking Current
$V_{TM}$	Maximum On State Voltage
$I_H$	Holding Current

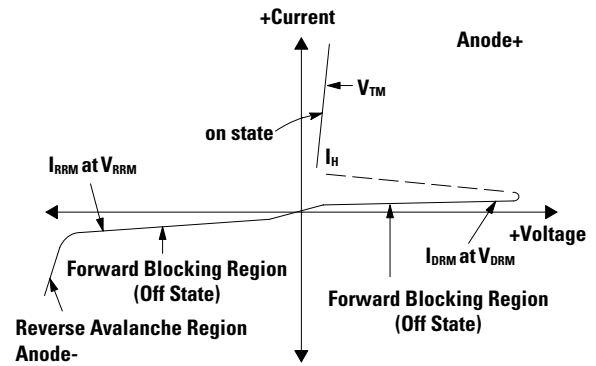

**Figure 1.**

PCB for Thermal Impedance and Power Testing of SOT-223

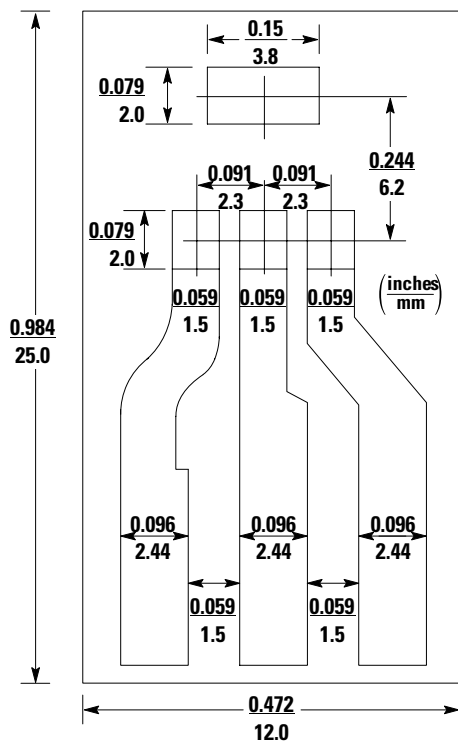

Board mounted vertically cinch 8840 edge connector.  
 Board Thickness = 65Mil.  
 Foil Thickness = 2.5Mil.  
 Material: G10 Fiberglass Base Epoxy

# MCR08B, MCR08M

Surface Mount – 600V - 800V

**Figure 2.**  
On-State Characteristics

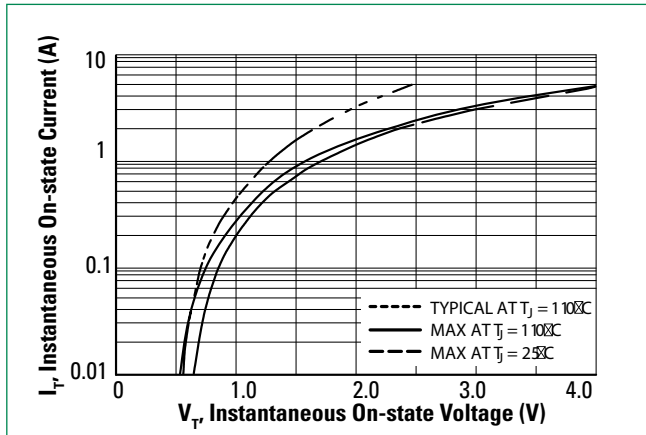

**Figure 3.**  
Junction to Ambient Thermal Resistance vs Copper Tab Area

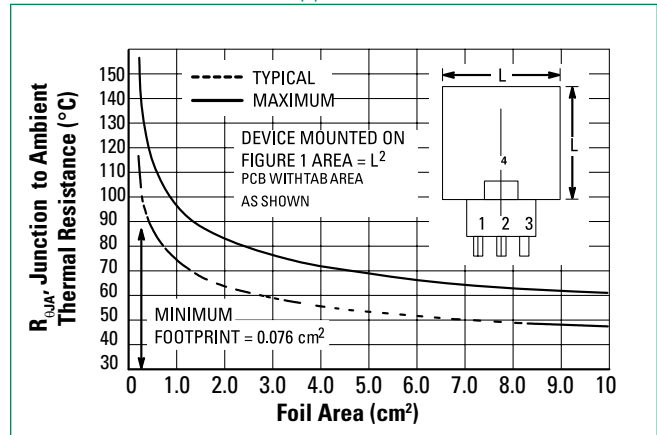

**Figure 4.**  
Current Derating, Minimum Pad Size Reference: Ambient Temperature

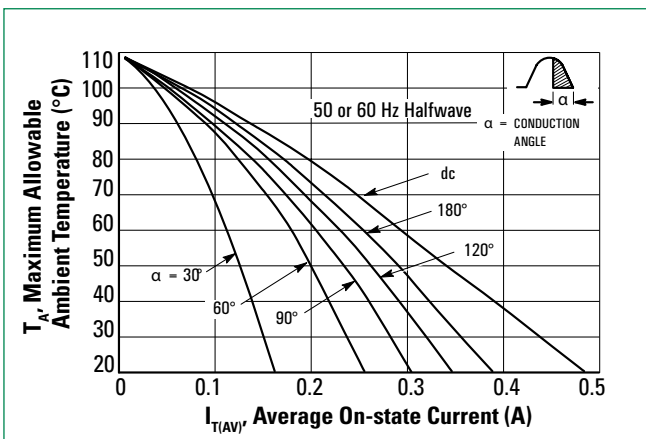

**Figure 5.**  
Current Derating, 1.0 cm Square Pad Reference: Ambient Temperature

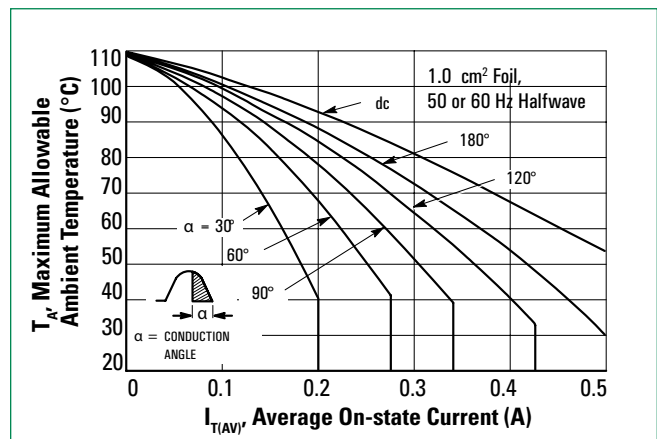

**Figure 6.**  
Current Derating, 2.0 cm Square Pad Reference: Ambient Temperature

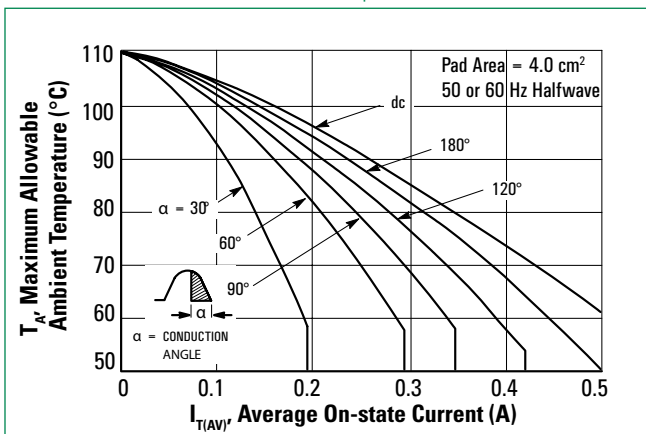

**Figure 7.**  
Current Derating Reference: Anode Tab

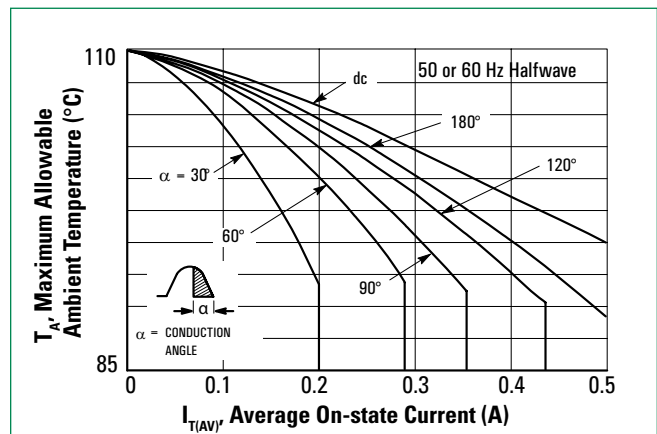

# MCR08B, MCR08M

Surface Mount – 600V - 800V

**Figure 8.**  
Power Dissipation

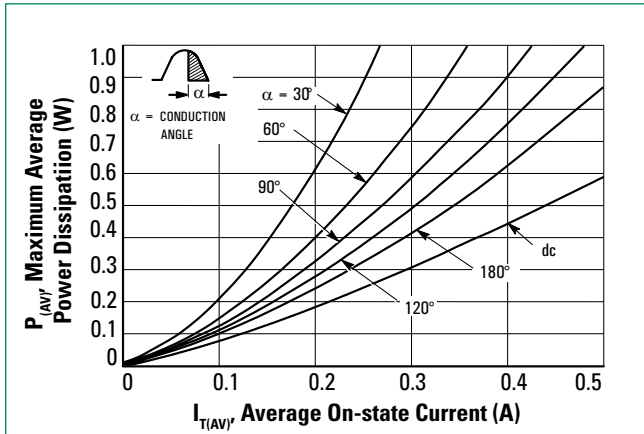

**Figure 9.**

Thermal Response Device Mounted on Figure 1 Printed Circuit Board

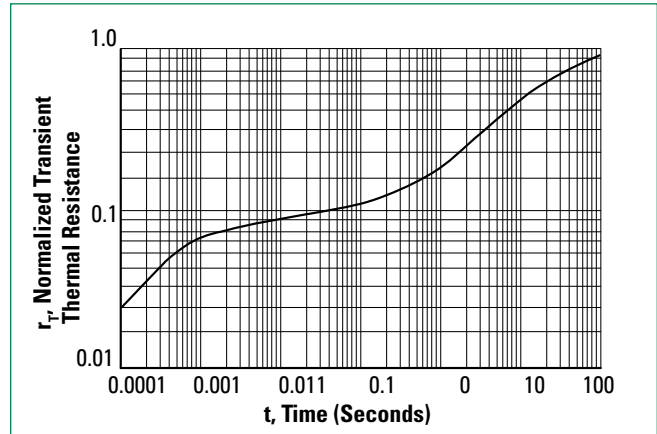

**Figure 10.**

Typical Gate Trigger Voltage vs Junction Temperature

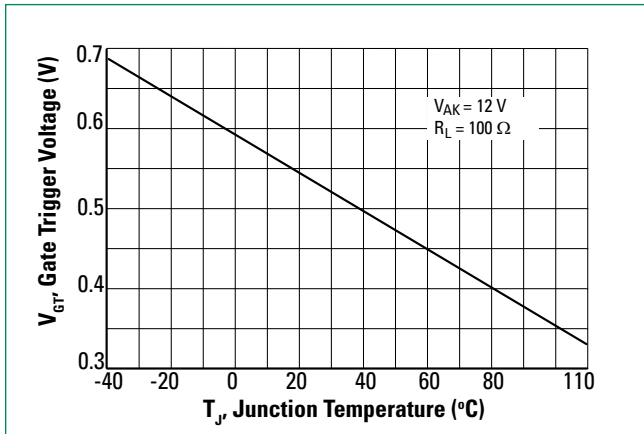

**Figure 11.**

Typical Normalized Holding Current vs Junction Temperature

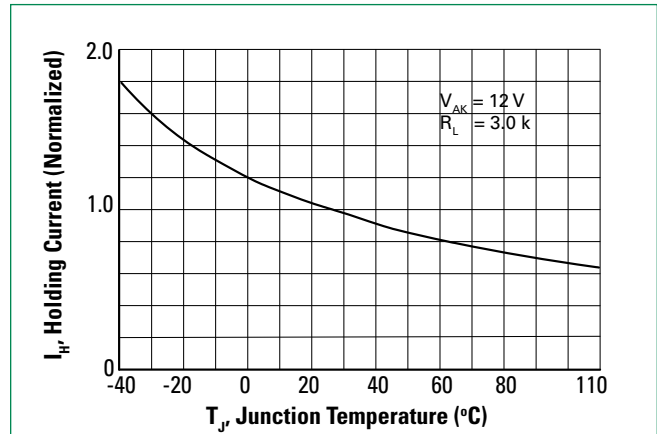

**Figure 12.**

Typical Range of VGT versus Measured IGT

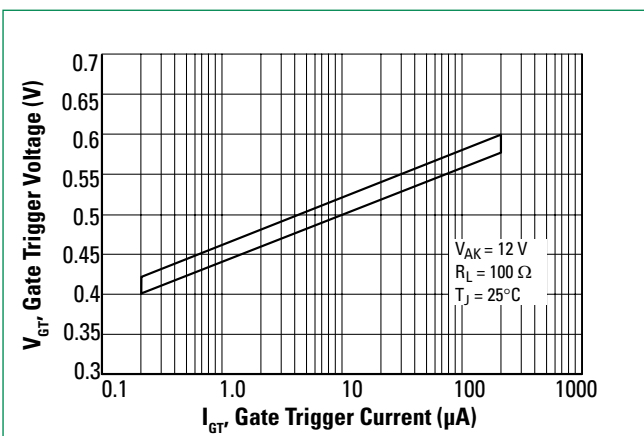

**Figure 13.**

Typical Gate Trigger Current vs Junction Temperature

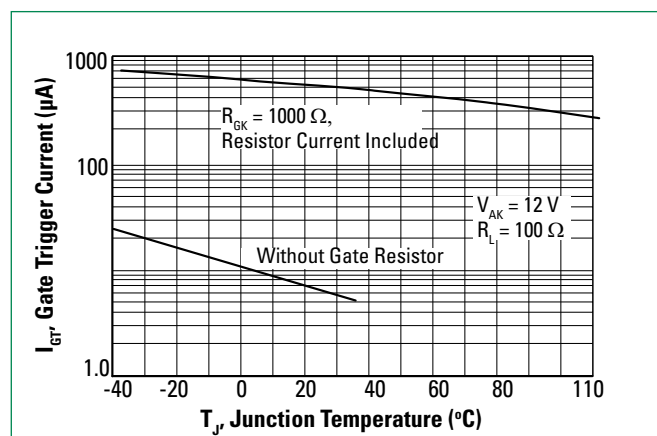

# MCR08B, MCR08M

Surface Mount – 600V - 800V

**Figure 14.**

Holding Current Range vs Gate-Cathode Resistance

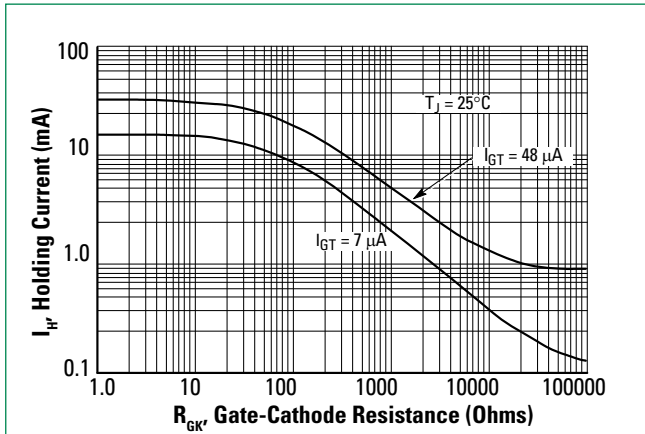

**Figure 15.**

Exponential Static dv/dt vs. Junction Temperature and Gate-Cathode Termination Resistance

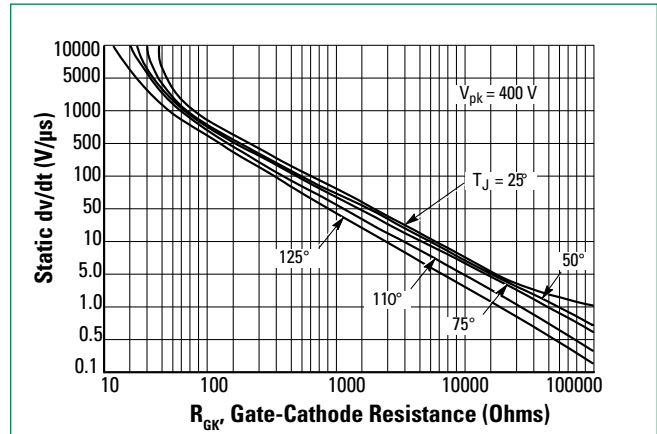

**Figure 16.**

Exponential Static dv/dt vs Peak Voltage and Gate-Cathode Termination Resistance

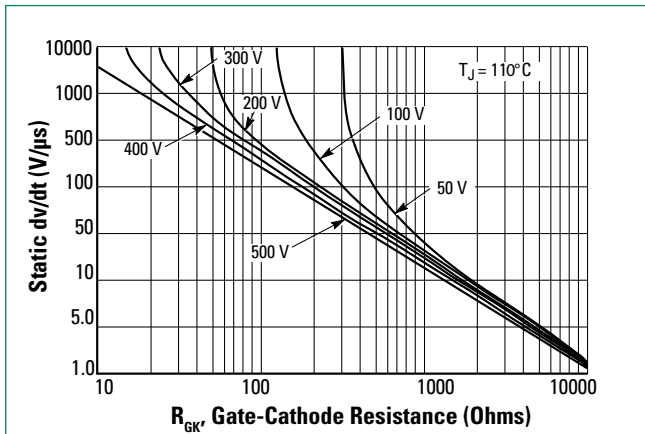

**Figure 17.**

Exponential Static dv/dt vs Gate-Cathode Capacitance and Resistance

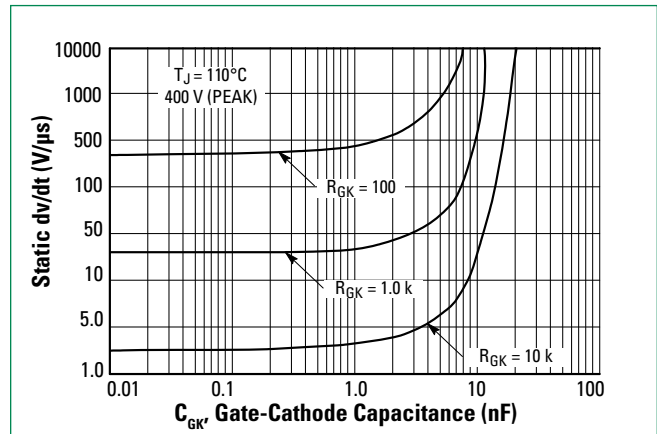

**Figure 18.**

Exponential Static dv/dt vs Gate-Cathode Termination Resistance and Product Trigger Current Sensitivity

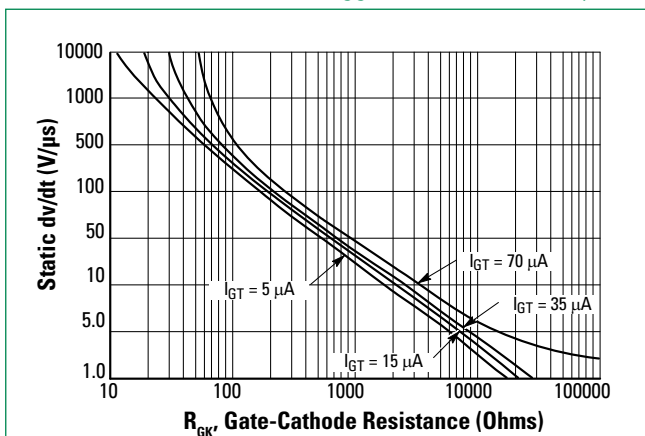

# MCR08B, MCR08M

Surface Mount – 600V - 800V

## Dimensions

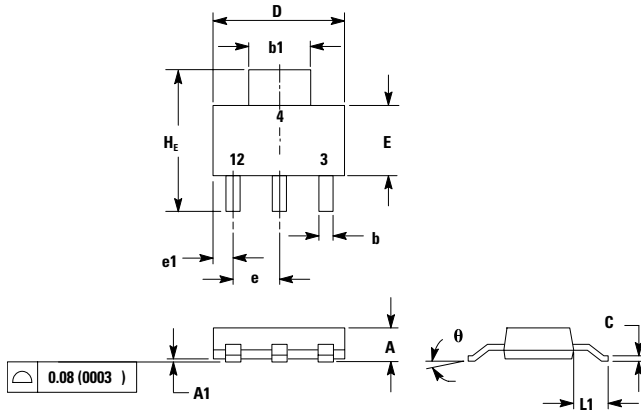

## Soldering Footprint

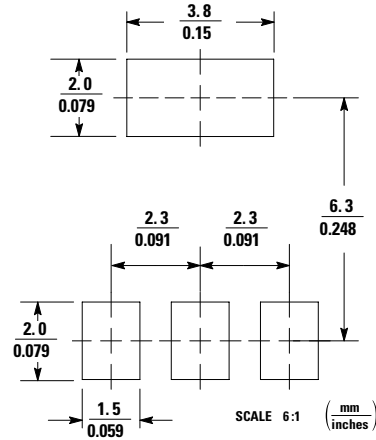

Dim	Millimeters			Inches		
	Min	Nom	Max	Min	Nom	Max
A	1.50	1.63	1.75	0.060	0.064	0.068
A1	0.02	0.06	0.10	0.001	0.002	0.004
b	0.60	0.75	0.89	0.024	0.030	0.035
b1	2.90	3.06	3.20	0.115	0.121	0.126
c	0.24	0.29	0.35	0.009	0.012	0.014
D	6.30	6.50	6.70	0.249	0.256	0.263
E	3.30	3.50	3.70	0.130	0.138	0.145
e	2.20	2.30	2.40	0.087	0.091	0.094
e1	0.85	0.94	1.05	0.033	0.037	0.041
L1	1.50	1.75	2.00	0.060	0.069	0.078
H <sub>E</sub>	6.70	7.00	7.30	0.264	0.276	0.287
θ	0°	–	10°	0°	–	10°

1. Dimensions and Tolerancing per Ansi Y14.5M. 1982.  
 2. Controlling Dimension: Inch.

## Part Marking System

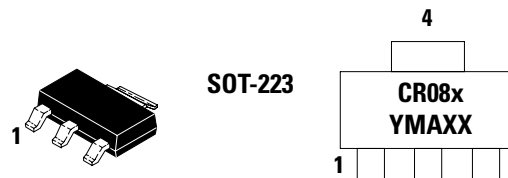

CR08x = Device Code  
 x = B or M  
 Y = Year  
 M = Month  
 A = Assembly Location  
 XX = Series Number

## Ordering Information

Device	Package	Shipping
MCR08BT1G	SOT-223 (Pb-Free)	1000/Tape & Reel
MCR08MT1G	SOT-223 (Pb-Free)	1000/Tape & Reel

## Pin Assignment

Pin	Assignment
1	Cathode
2	Anode
3	Gate
4	Anode

**Disclaimer Notice** - Information furnished is believed to be accurate and reliable. However, users should independently evaluate the suitability of and test each product selected for their own applications. Littelfuse products are not designed for, and may not be used in, all applications. Read complete Disclaimer Notice at: [www.littelfuse.com/disclaimer-electronics](http://www.littelfuse.com/disclaimer-electronics)