

# SC3051-04HTG

## 6 V, 22 A, SOT23-6, Lightning Surge Protection

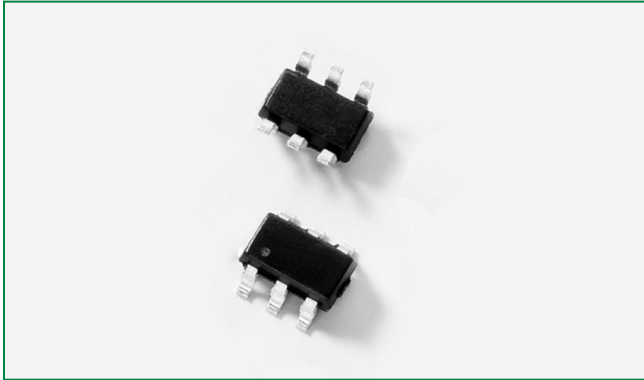

### Pinout

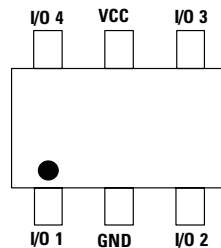

Top View

### Functional Block Diagram

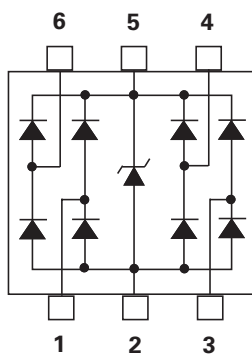

### Applications

- 10/100/1000 Ethernet
- Firewire
- Flat panel displays
- LCD/PDP TVs
- Monitors
- Notebooks
- Portable medical
- Set top boxes

### Life Support Note:

Not Intended for Use in Life Support or Life Saving Applications

The products shown herein are not designed for use in life sustaining or life saving applications unless otherwise expressly indicated.

## Description

The SC3051-04HTG TVS diode array integrates low-capacitance rail-to-rail diodes with an additional Zener diode to protect each I/O pin against ESD and high surge events. This robust component can safely absorb 22 A of current per IEC 61000-4-5 ( $t_p = 8/20 \mu s$ ) without performance degradation and has a minimum  $\pm 30$  kV ESD rating per IEC 61000-4-2 2nd edition. Their very low off-state capacitance is compatible with high-speed circuits.

## Features

- ESD, IEC 61000-4-2,  $\pm 30$  kV contact/air
- EFT, IEC 61000-4-4, 40 A (5/50 ns)
- Maximum surge tolerance, IEC 61000-4-5 2<sup>nd</sup> edition, 22 A (8/20  $\mu s$ )
- Low capacitance of 2.0 pF (typ) per I/O
- Low leakage current of 0.5  $\mu A$  (max) at 6 V
- Small SOT23-6 packaging
- Halogen-free, lead-free, and RoHS-compliant

## Application Examples

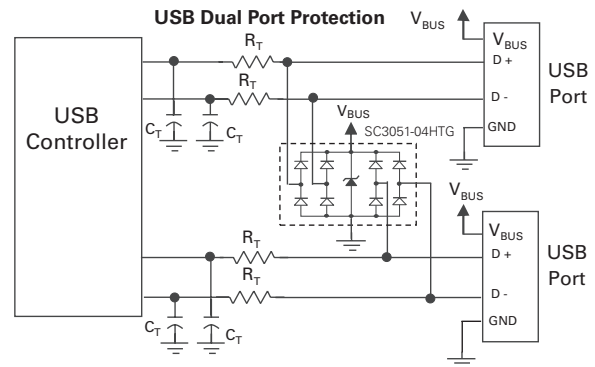

### 10/100/1000 Ethernet Protection

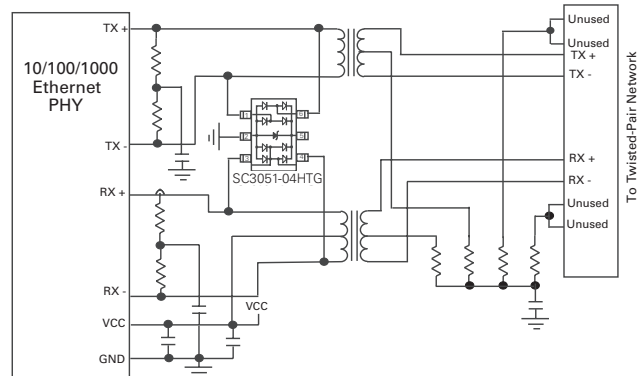

# SC3051-04HTG

## 6 V, 22 A, SOT23-6, Lightning Surge Protection

### Absolute Maximum Ratings

Symbol	Parameter	Value	Units
$I_{PP}$	Peak Current ( $t_p = 8/20 \mu s$ )	22	A
$T_{OP}$	Operating Temperature	-40 to 125	°C
$T_{STOR}$	Storage Temperature	-55 to 150	°C

**Caution:** Stresses above those listed in "Absolute Maximum Ratings" may cause permanent damage to the component. This is a stress only rating and operation of the component at these or any other conditions above those indicated in the operational sections of this specification is not implied.

### Electrical Characteristics ( $T_{OP} = 25 \text{ }^\circ\text{C}$ )

Parameter	Symbol	Test Conditions	Min	Typ	Max	Units
Reverse Standoff Voltage	$V_{RWM}$				6	V
Breakdown Voltage	$V_{BR}$	$I_R = 1 \text{ mA}$ , I/O to GND	7	8.5	10	V
Reverse Leakage Current	$I_{LEAK}$	$V_R = 6 \text{ V}$ , I/O to GND		0.1	0.5	$\mu\text{A}$
Clamp Voltage <sup>1</sup>	$V_C$	$I_{PP} = 1 \text{ A}$ , $t_p = 8/20 \mu s$ , I/O to GND		9.0	10.5	V
		$I_{PP} = 10 \text{ A}$ , $t_p = 8/20 \mu s$ , I/O to GND		11.5	15.0	
		$I_{PP} = 22 \text{ A}$ , $t_p = 8/20 \mu s$ , I/O to GND		14.3	17	
Dynamic Resistance <sup>2</sup>	$R_{DYN}$	TLP, $t_p = 100 \text{ ns}$ , I/O to GND		0.15		$\Omega$
ESD Withstand Voltage <sup>1,3</sup>	$V_{ESD}$	IEC 61000-4-2 (Contact Discharge)	$\pm 30$			kV
		IEC 61000-4-2 (Air Discharge)	$\pm 30$			kV
Diode Capacitance <sup>1</sup>	$C_{IO-GND}$	Reverse Bias = 0 V, $f = 1 \text{ MHz}$		2.0		pF
		$V_{CC} = 5 \text{ V}$ , Reverse Bias = 2.5 V, $f = 1 \text{ MHz}$		1.0	1.5	

**Note:**

- Parameter is guaranteed by design and/or component characterization.
- Transmission Line Pulse (TLP) with 100 ns width, 0.2 ns rise time, and average window  $t_1 = 70 \text{ ns}$  to  $t_2 = 90 \text{ ns}$
- Device stressed with ten non-repetitive ESD pulses.

### Capacitance vs. Reverse Bias

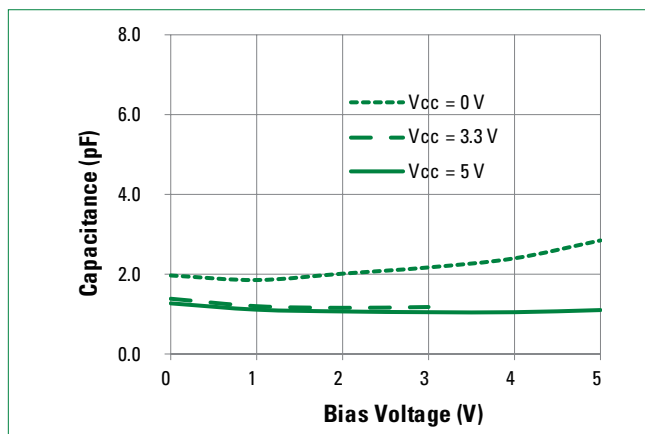

### Clamping Voltage vs $I_{PP}$

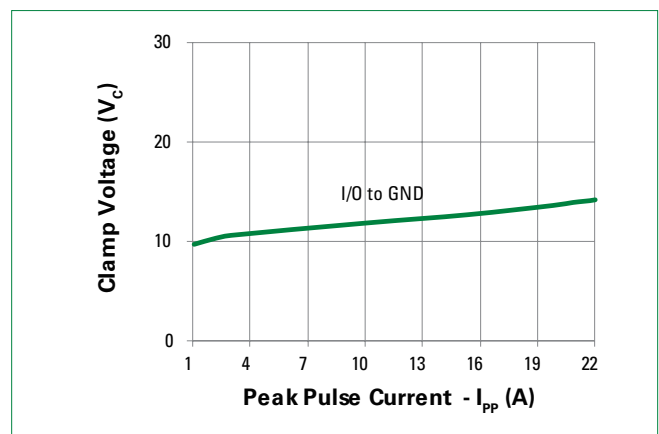

**SC3051-04HTG**

6 V, 22 A, SOT23-6, Lightning Surge Protection

Positive Transmission Line Pulsing (TLP) Plot

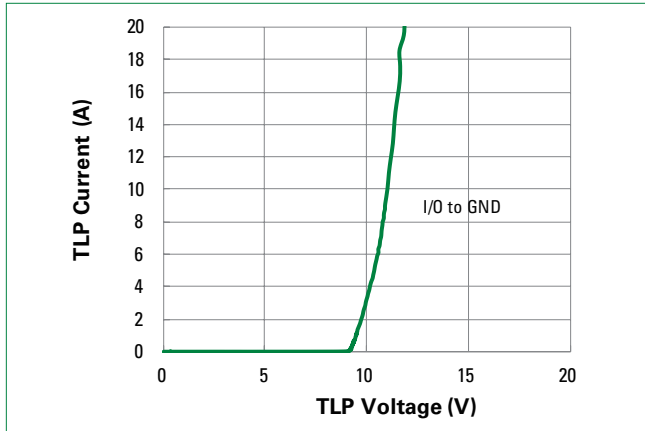

Negative Transmission Line Pulsing (TLP) Plot

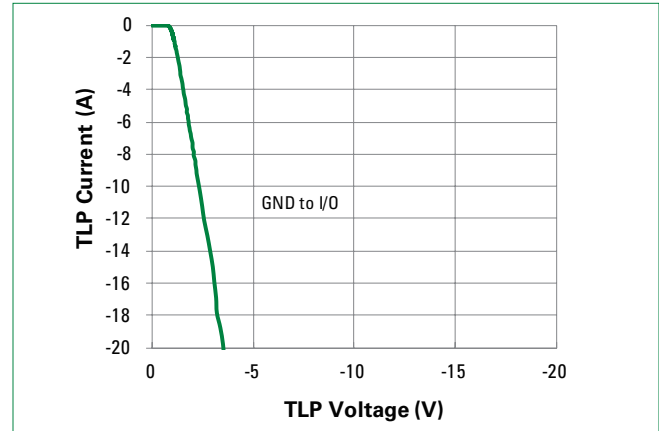

IEC 61000-4-2 +8 kV Contact ESD Clamping Voltage

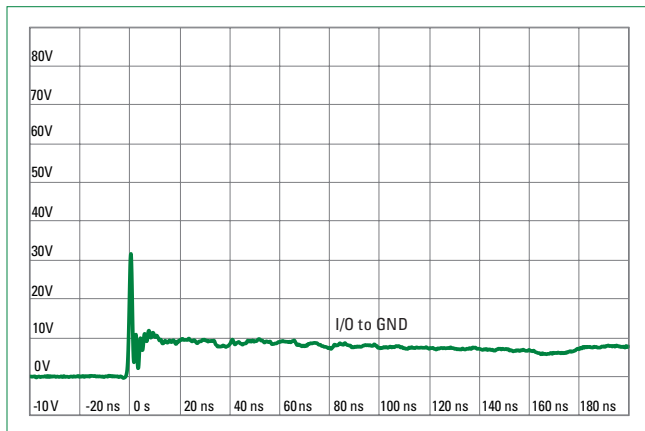

IEC 61000-4-2 -8 kV Contact ESD Clamping Voltage

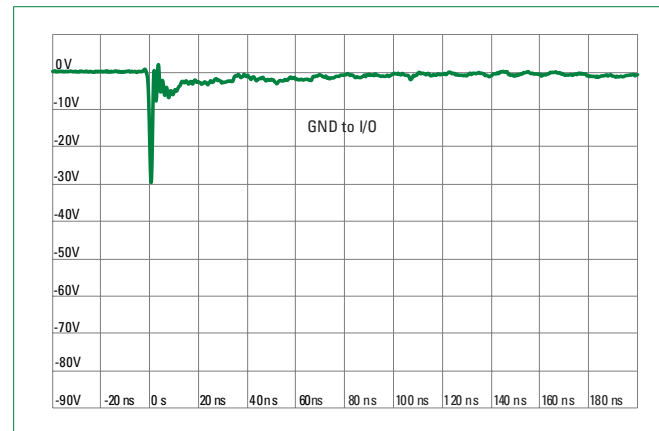

# SC3051-04HTG

## 6 V, 22 A, SOT23-6, Lightning Surge Protection

### Soldering Parameters

<b>Reflow Condition</b>		Pb – free assembly
<b>Pre Heat</b>	- Temperature Min ( $T_{s(min)}$ )	150 °C
	- Temperature Max ( $T_{s(max)}$ )	200 °C
	- Time (min to max) ( $t_s$ )	60 – 120 seconds
<b>Average Ramp Up Rate (Liquidus) Temp (<math>T_L</math>) to Peak</b>		3 °C/second max
<b><math>T_{s(max)}</math> to <math>T_L</math> - Ramp-up Rate</b>		3 °C/second max
<b>Reflow</b>	- Temperature ( $T_L$ ) (Liquidus)	217 °C
	- Temperature ( $t_L$ )	60 – 150 seconds
<b>Peak Temperature (<math>T_p</math>)</b>		260 <sup>+0/-5</sup> °C
<b>Time Within 5°C of Actual Peak Temperature (<math>t_p</math>)</b>		30 seconds
<b>Ramp-down Rate</b>		6 °C/second max
<b>Time 25°C to Peak Temperature (<math>T_p</math>)</b>		8 minutes max
<b>Do Not Exceed</b>		260 °C

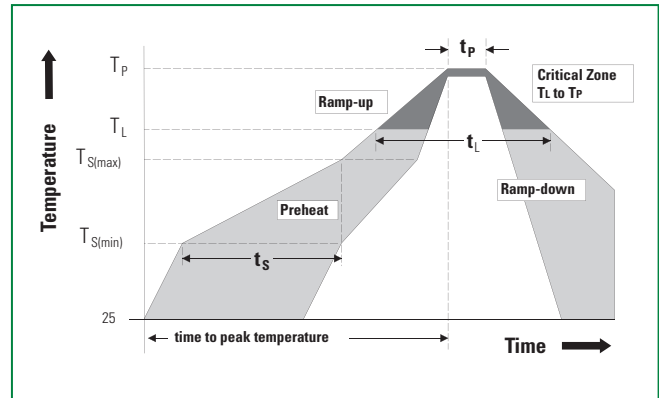

### Ordering Information

Part Number	Package	Min. Order Qty.
SC3051-04HTG	SOT23-6	3000

### Product Characteristics

<b>Lead Plating</b>	Matte tin
<b>Lead Material</b>	Copper alloy
<b>Body Material</b>	Molded compound
<b>Flammability</b>	UL recognized compound meeting flammability rating V-0

### Part Numbering System

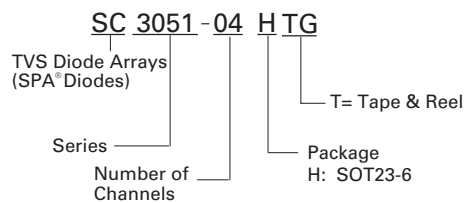

### Part Marking System

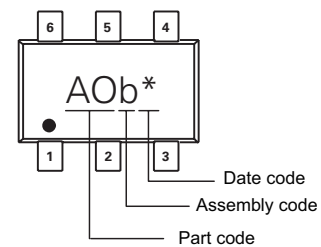

# SC3051-04HTG

6 V, 22 A, SOT23-6, Lightning Surge Protection

## Package Dimensions - SOT23-6

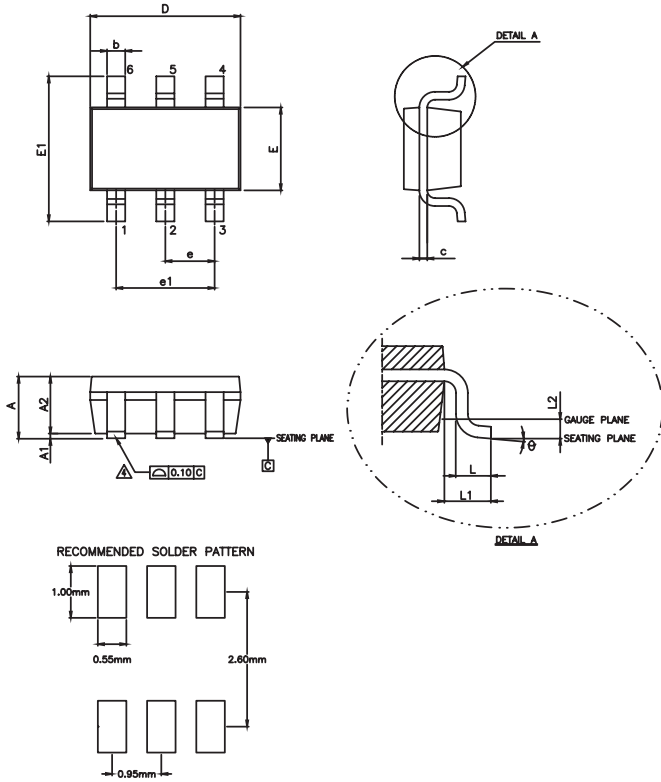

Symbol	Millimeters		Inches	
	Min	Max	Min	Max
A	-	1.45	-	0.057
A1	0.00	0.15	0.000	0.006
A2	0.90	1.30	0.035	0.051
b	0.25	0.50	0.010	0.020
c	0.08	0.22	0.003	0.009
D	2.82	3.02	0.111	0.119
E	1.50	1.70	0.059	0.067
E1	2.60	3.00	0.102	0.118
e	0.95 BSC.		0.037 BSC.	
e1	1.90 BSC.		0.075 BSC.	
L	0.30	0.55	0.012	0.022
L1	0.60 REF.		0.024 REF.	
L2	0.25 REF.		0.010 REF.	
θ	0°	8°	0°	8°

## Embossed Carrier Tape & Reel Specification — SOT23-6

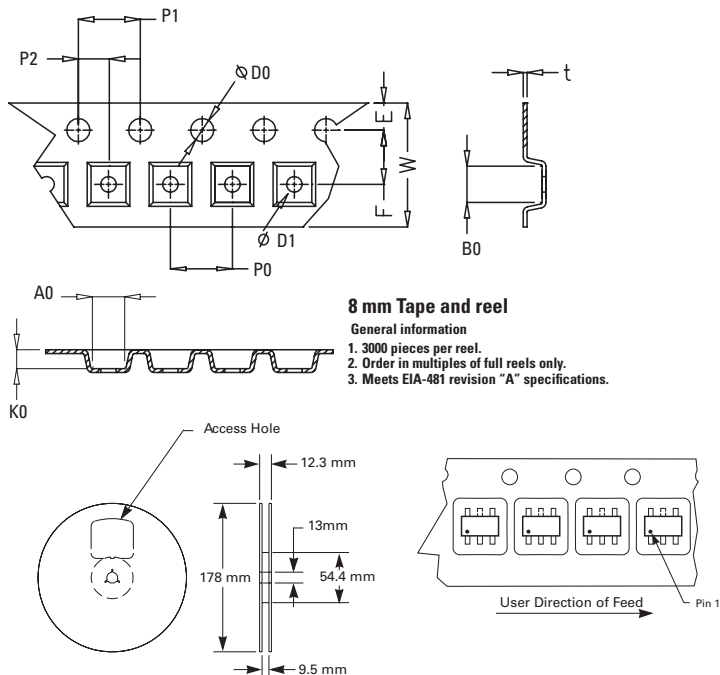

### 8 mm Tape and reel

- General information
- 3000 pieces per reel.
  - Order in multiples of full reels only.
  - Meets EIA-481 revision "A" specifications.

Symbol	Millimeters
A0	3.17+/-0.10
B0	3.23+/-0.10
W	8.00+0.30/-0.10
D0	1.50+0.10
D1	1.00+0.25
E	1.75+/-0.10
F	3.50+/-0.10
P0	4.00+/-0.10
P1	4.00+/-0.10
P2	2.00+/-0.05
K0	1.37+/-0.10
T	0.25+/-0.03

**Disclaimer Notice** - Information furnished is believed to be accurate and reliable. However, users should independently evaluate the suitability of and test each product selected for their own applications. Littelfuse products are not designed for, and may not be used in, all applications. Read complete Disclaimer Notice at <http://www.littelfuse.com/disclaimer-electronics>.

# SC3051-04HTG

## 5 V, 22 A, SOT23-6, Lightning Surge Protection

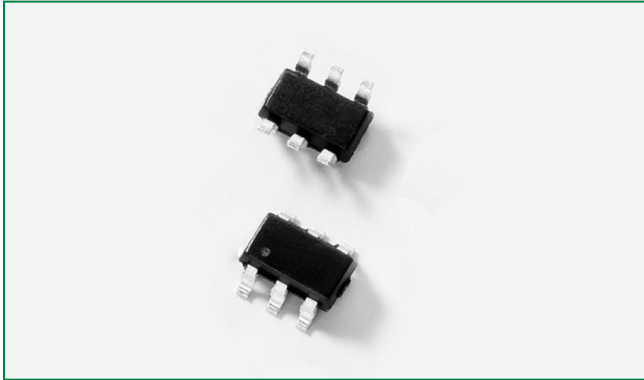

### Pinout

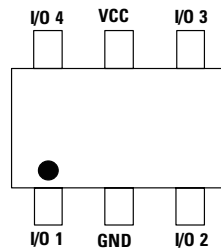

Top View

### Functional Block Diagram

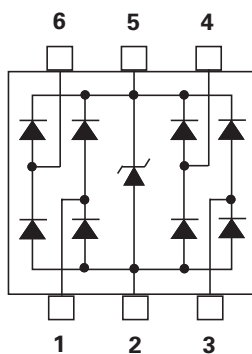

### Applications

- 10/100/1000 Ethernet
- Firewire
- Flat Panel Displays
- LCD/PDP TVs
- Monitors
- Notebooks
- Portable Medical
- Set Top Boxes

### Life Support Note:

Not Intended for Use in Life Support or Life Saving Applications

The products shown herein are not designed for use in life sustaining or life saving applications unless otherwise expressly indicated.

## Description

The SC3051-04HTG integrates low capacitance rail-to-rail diodes with an additional zener diode to protect each I/O pin against ESD and high surge events. This robust component can safely absorb 22 A of current per IEC 61000-4-5 ( $t_p = 8/20 \mu s$ ) without performance degradation and has a minimum  $\pm 30$  kV ESD rating per IEC 61000-4-2 2<sup>nd</sup> edition. Their very low off-state capacitance is compatible with high speed circuits.

## Features

- ESD, IEC 61000-4-2,  $\pm 30$  kV contact/air
- EFT, IEC 61000-4-4, 40 A (5/50 ns)
- Maximum surge tolerance, IEC 61000-4-5 2<sup>nd</sup> edition, 22 A (8/20  $\mu s$ )
- Low capacitance of 2.0 pF (TYP) per I/O
- Low leakage current of 0.5  $\mu A$  (MAX) at 5 V
- Small SOT23-6 packaging
- Halogen free, lead free and RoHS compliant

## Application Examples

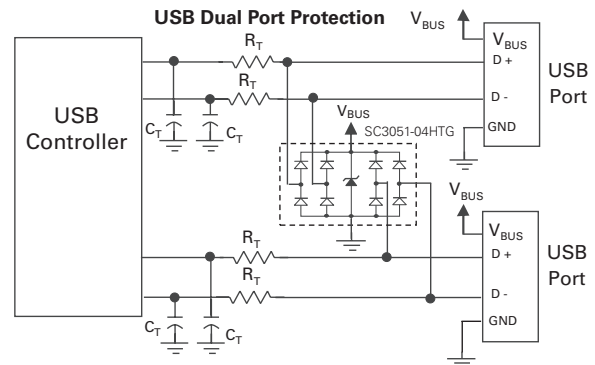

### 10/100/1000 Ethernet Protection

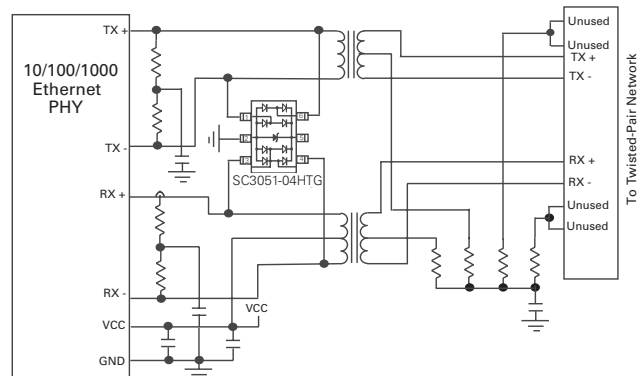

# SC3051-04HTG

## 5 V, 22 A, SOT23-6, Lightning Surge Protection

### Absolute Maximum Ratings

Symbol	Parameter	Value	Units
$I_{PP}$	Peak Current ( $t_p = 8/20 \mu s$ )	22	A
$T_{OP}$	Operating Temperature	-40 to 125	°C
$T_{STOR}$	Storage Temperature	-55 to 150	°C

**CAUTION:** Stresses above those listed in "Absolute Maximum Ratings" may cause permanent damage to the component. This is a stress only rating and operation of the component at these or any other conditions above those indicated in the operational sections of this specification is not implied.

### Electrical Characteristics ( $T_{OP} = 25 \text{ }^\circ\text{C}$ )

Parameter	Symbol	Test Conditions	Min	Typ	Max	Units
Reverse Standoff Voltage	$V_{RWM}$				5	V
Breakdown Voltage	$V_{BR}$	$I_R = 1 \text{ mA}$ , $V_{CC}$ to GND	6.0	7.5	9.0	V
Reverse Leakage Current	$I_{LEAK}$	$V_R = 5 \text{ V}$ , $V_{CC}$ to GND		0.1	0.5	$\mu\text{A}$
Clamp Voltage <sup>1</sup>	$V_C$	$I_{PP} = 1 \text{ A}$ , $t_p = 8/20 \mu s$ , I/O to GND		9.0	10.5	V
		$I_{PP} = 10 \text{ A}$ , $t_p = 8/20 \mu s$ , I/O to GND		11.5	15.0	
		$I_{PP} = 22 \text{ A}$ , $t_p = 8/20 \mu s$ , I/O to GND		14.3	17	
Dynamic Resistance <sup>2</sup>	$R_{DYN}$	TLP, $t_p = 100 \text{ ns}$ , I/O to GND		0.15		$\Omega$
ESD Withstand Voltage <sup>1,3</sup>	$V_{ESD}$	IEC 61000-4-2 (Contact Discharge)	$\pm 30$			kV
		IEC 61000-4-2 (Air Discharge)	$\pm 30$			kV
Diode Capacitance <sup>1</sup>	$C_{IO-GND}$	Reverse Bias = 0 V, $f = 1 \text{ MHz}$		2.0		pF
		$V_{CC} = 5 \text{ V}$ , Reverse Bias = 2.5 V, $f = 1 \text{ MHz}$		1.0	1.5	

**Note:**

Note:

- Parameter is guaranteed by design and/or component characterization.
- Transmission Line Pulse (TLP) with 100 ns width, 0.2 ns rise time, and average window  $t_1 = 70 \text{ ns}$  to  $t_2 = 90 \text{ ns}$
- Device stressed with ten non-repetitive ESD pulses.

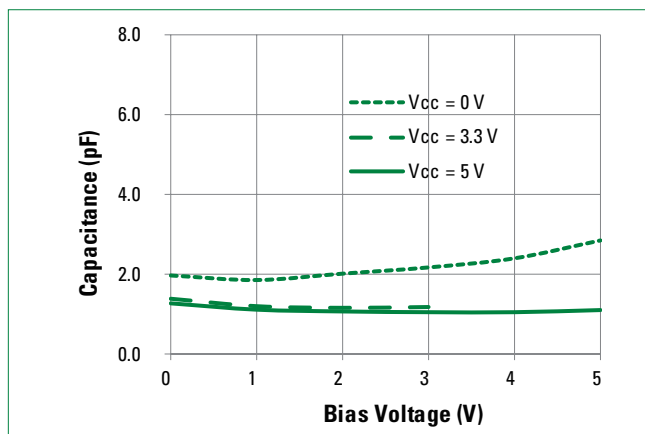
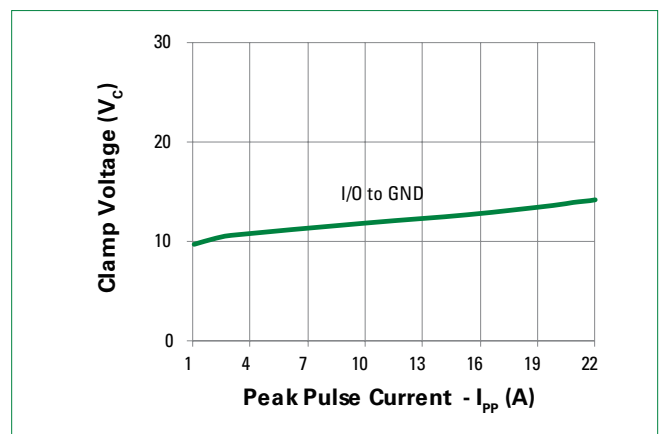
**Capacitance vs. Reverse Bias****Clamping Voltage vs  $I_{PP}$** 

**SC3051-04HTG**

5 V, 22 A, SOT23-6, Lightning Surge Protection

Positive Transmission Line Pulsing (TLP) Plot

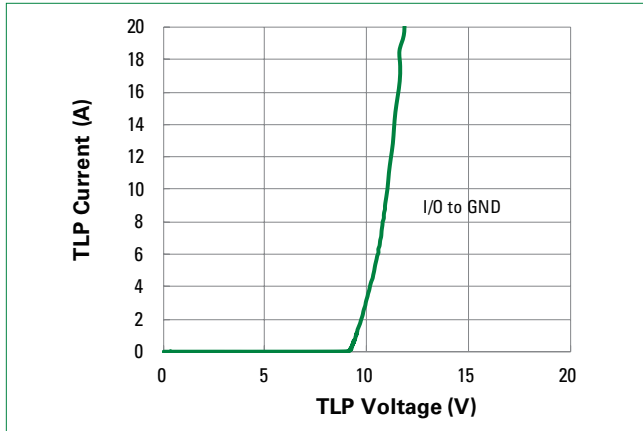

Negative Transmission Line Pulsing (TLP) Plot

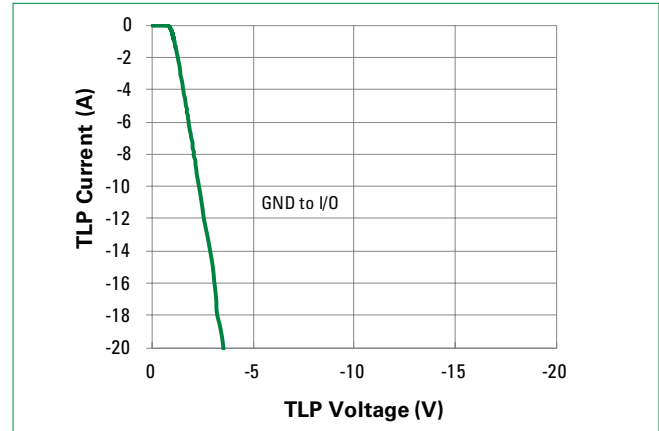

IEC 61000-4-2 +8 kV Contact ESD Clamping Voltage



IEC 61000-4-2 -8 kV Contact ESD Clamping Voltage

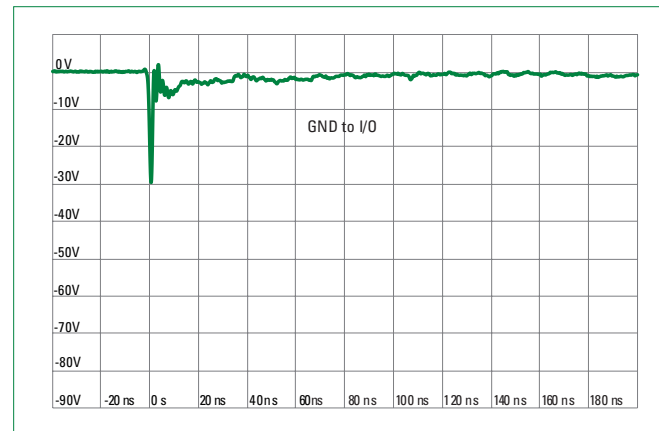



# SC3051-04HTG

## 5 V, 22 A, SOT23-6, Lightning Surge Protection

### Soldering Parameters

<b>Reflow Condition</b>		Pb – free assembly
<b>Pre Heat</b>	- Temperature Min ( $T_{s(min)}$ )	150 °C
	- Temperature Max ( $T_{s(max)}$ )	200 °C
	- Time (min to max) ( $t_s$ )	60 – 120 seconds
<b>Average Ramp Up Rate (Liquidus) Temp (<math>T_L</math>) to Peak</b>		3 °C/second max
<b><math>T_{s(max)}</math> to <math>T_L</math> - Ramp-up Rate</b>		3 °C/second max
<b>Reflow</b>	- Temperature ( $T_L$ ) (Liquidus)	217 °C
	- Temperature ( $t_L$ )	60 – 150 seconds
<b>Peak Temperature (<math>T_p</math>)</b>		260 <sup>+0/-5</sup> °C
<b>Time Within 5°C of Actual Peak Temperature (<math>t_p</math>)</b>		30 seconds
<b>Ramp-down Rate</b>		6 °C/second max
<b>Time 25°C to Peak Temperature (<math>T_p</math>)</b>		8 minutes max
<b>Do Not Exceed</b>		260 °C

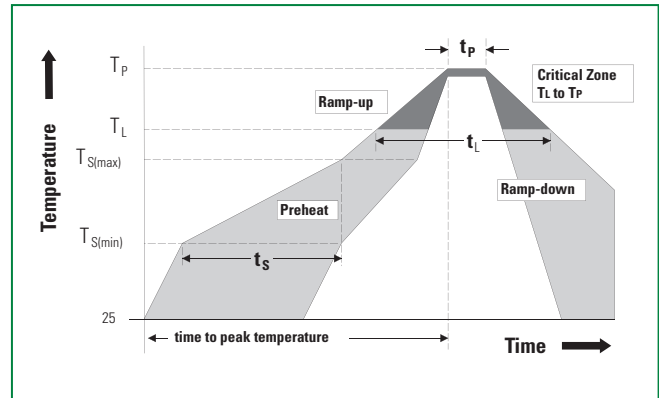

### Ordering Information

Part Number	Package	Min. Order Qty.
SC3051-04HTG	SOT23-6	3000

### Product Characteristics

<b>Lead Plating</b>	Matte tin
<b>Lead Material</b>	Copper alloy
<b>Body Material</b>	Molded compound
<b>Flammability</b>	UL recognized compound meeting flammability rating V-0

### Part Numbering System

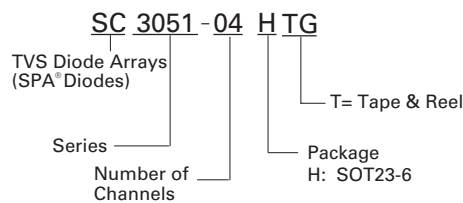

### Part Marking System

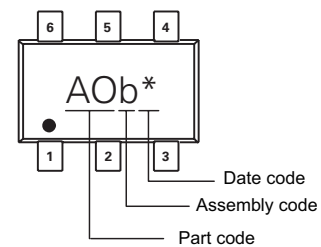

**SC3051-04HTG**

5 V, 22 A, SOT23-6, Lightning Surge Protection

## Package Dimensions - SOT23-6

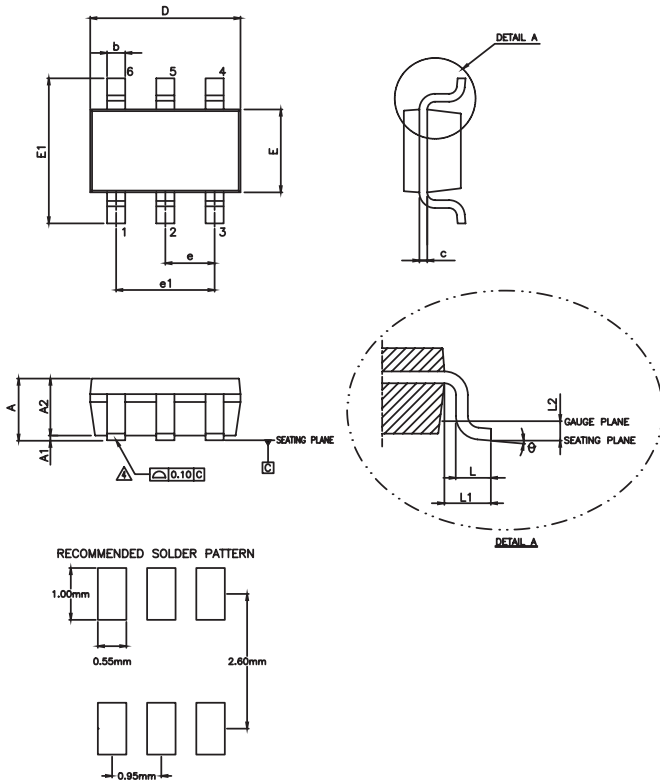

Symbol	Millimeters		Inches	
	Min	Max	Min	Max
A	-	1.45	-	0.057
A1	0.00	0.15	0.000	0.006
A2	0.90	1.30	0.035	0.051
b	0.25	0.50	0.010	0.020
c	0.08	0.22	0.003	0.009
D	2.82	3.02	0.111	0.119
E	1.50	1.70	0.059	0.067
E1	2.60	3.00	0.102	0.118
e	0.95 BSC.		0.037 BSC.	
e1	1.90 BSC.		0.075 BSC.	
L	0.30	0.55	0.012	0.022
L1	0.60 REF.		0.024 REF.	
L2	0.25 REF.		0.010 REF.	
θ	0°	8°	0°	8°

## Embossed Carrier Tape &amp; Reel Specification — SOT23-6

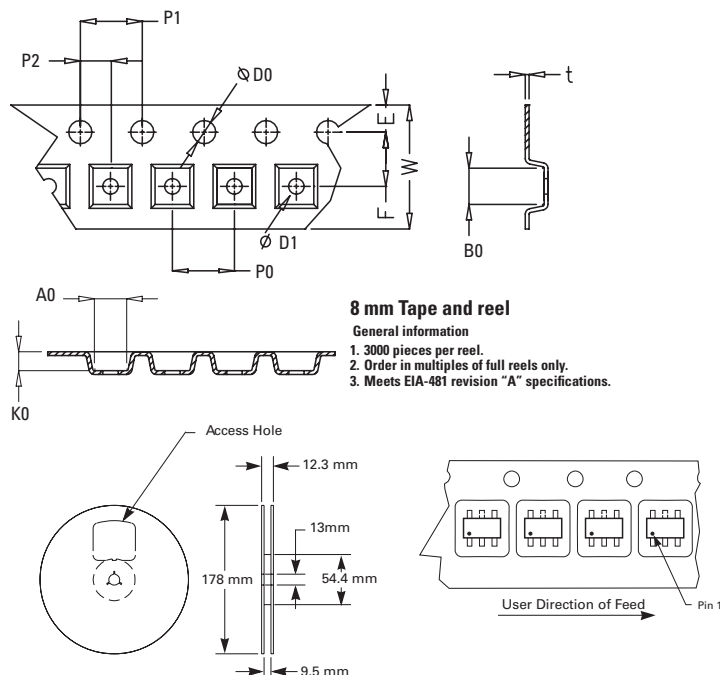
**8 mm Tape and reel**

## General information

- 3000 pieces per reel.
- Order in multiples of full reels only.
- Meets EIA-481 revision "A" specifications.

Symbol	Millimeters
A0	3.17+/-0.10
B0	3.23+/-0.10
W	8.00+0.30/-0.10
D0	1.50+0.10
D1	1.00+0.25
E	1.75+/-0.10
F	3.50+/-0.10
P0	4.00+/-0.10
P1	4.00+/-0.10
P2	2.00+/-0.05
K0	1.37+/-0.10
T	0.25+/-0.03

**Disclaimer Notice** - Information furnished is believed to be accurate and reliable. However, users should independently evaluate the suitability of and test each product selected for their own applications. Littelfuse products are not designed for, and may not be used in, all applications. Read complete Disclaimer Notice at <http://www.littelfuse.com/disclaimer-electronics>.