

PART NUMBER	UPC CODE
LM32003PJ	07945831083

REVISION		
REV	DATE	DESCRIPTION
A	5/4/23	526430GCP - RELEASE PER EM3380 MRY
B	4/15/24	527548ECP/C - UPDATE WIRE RANGE IN SIDE PRINTING MRY

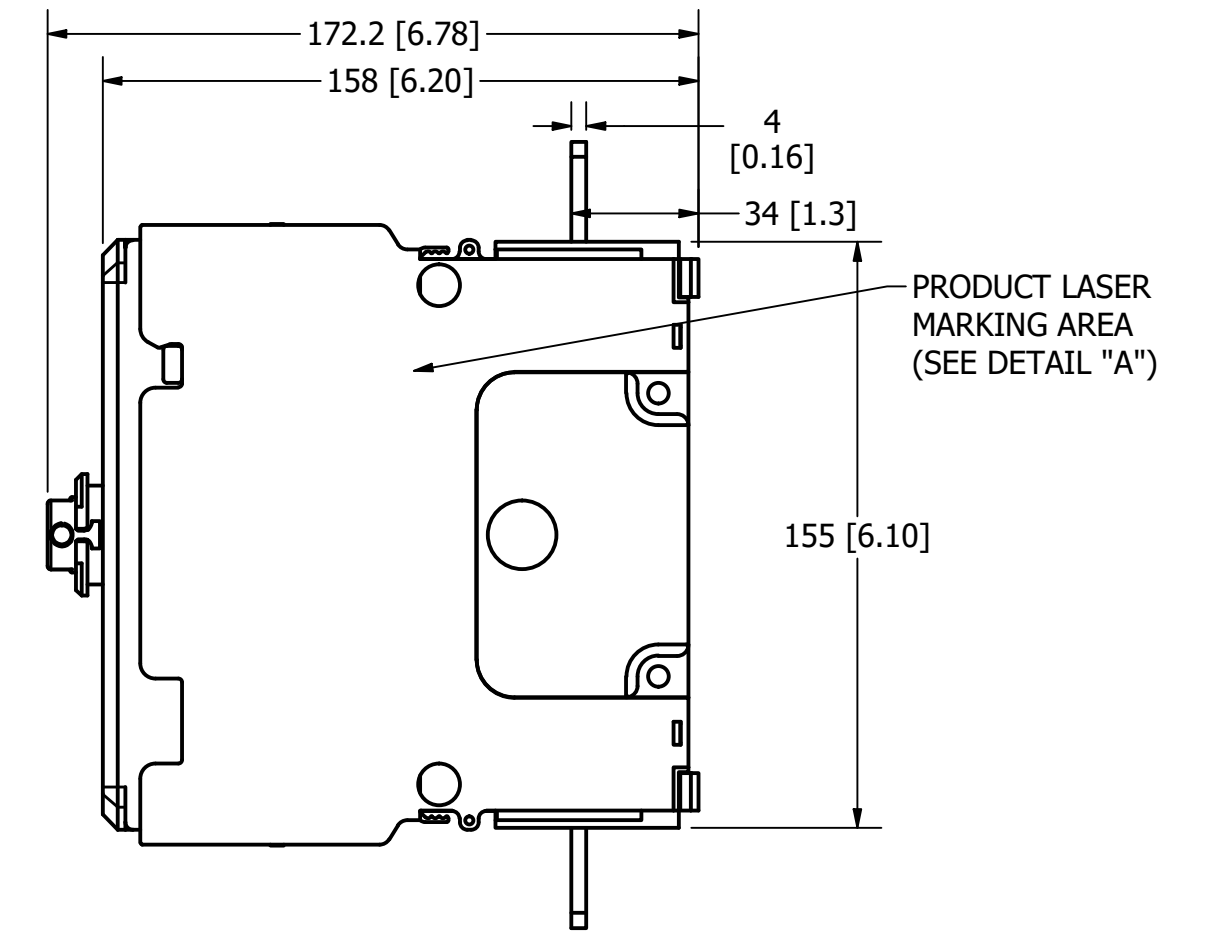

LM32003PJ
 L: 0123456789; NS: 01234
 UL 98
 600Vac 200A 50/60Hz
 General purpose switch
Use Cu wire only
 75°C 3/0AWG - 300MCM Wire
 Terminal Torque 159 LB.IN.
 With KIT Terminal Lugs LDM3TLU11
 Motor-Circuit Switch

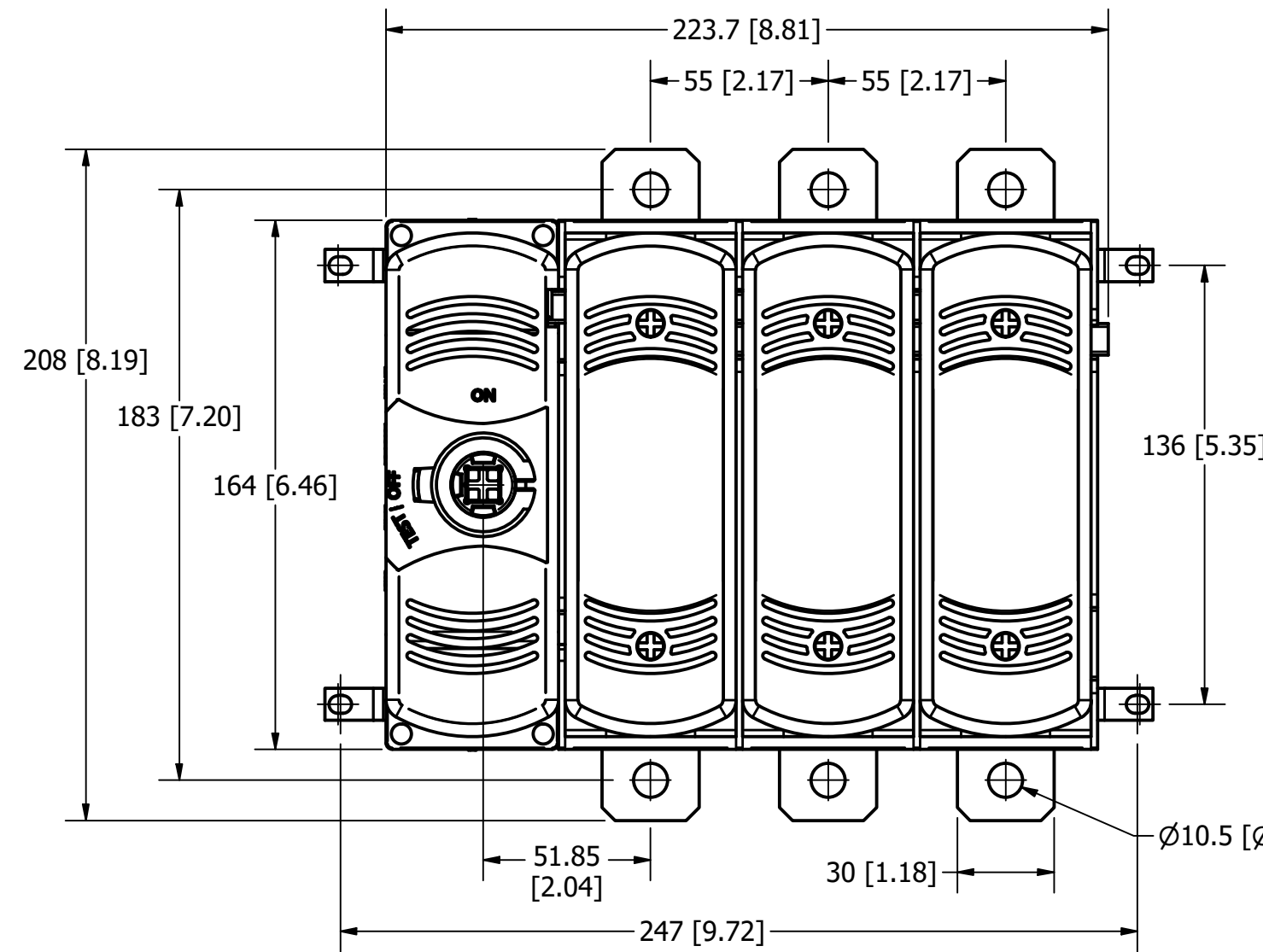
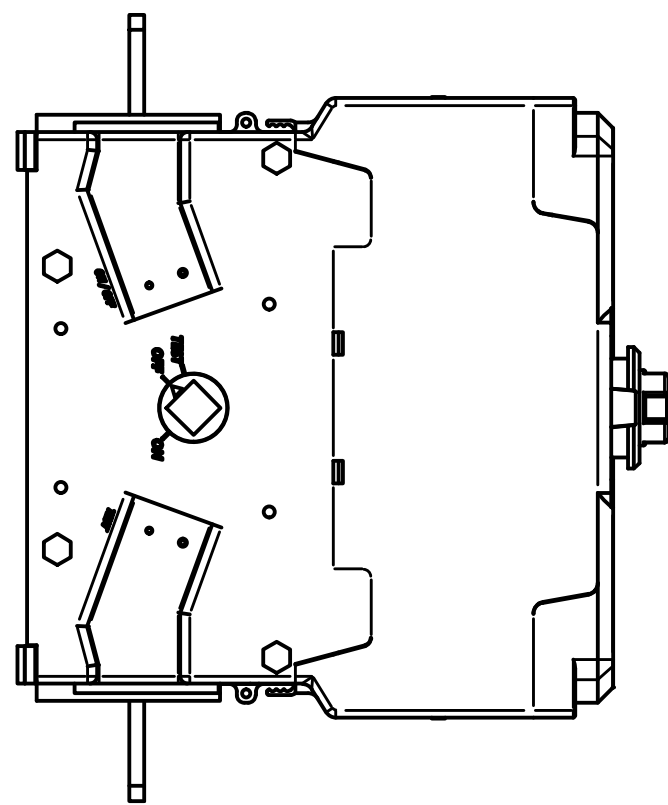
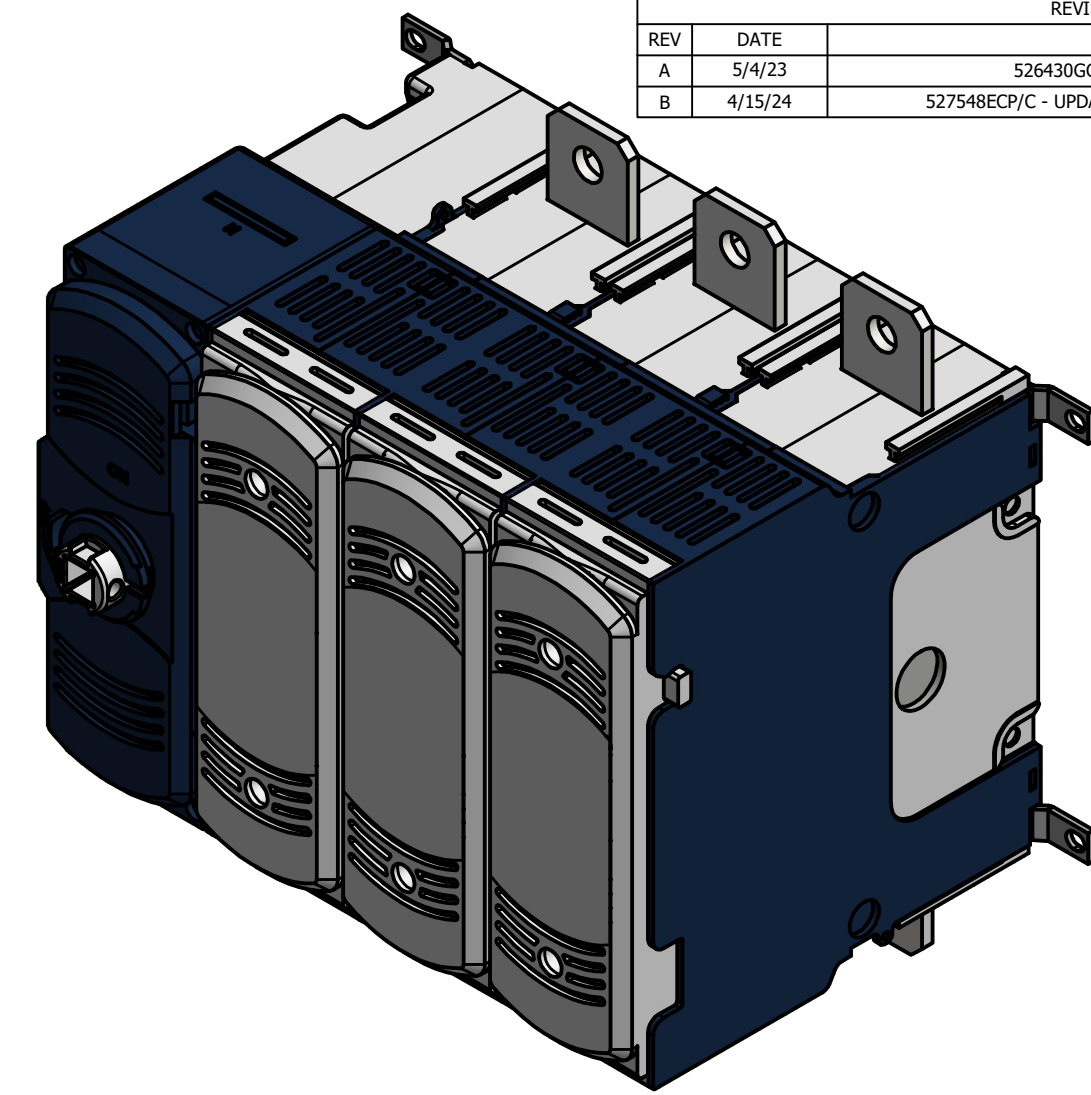
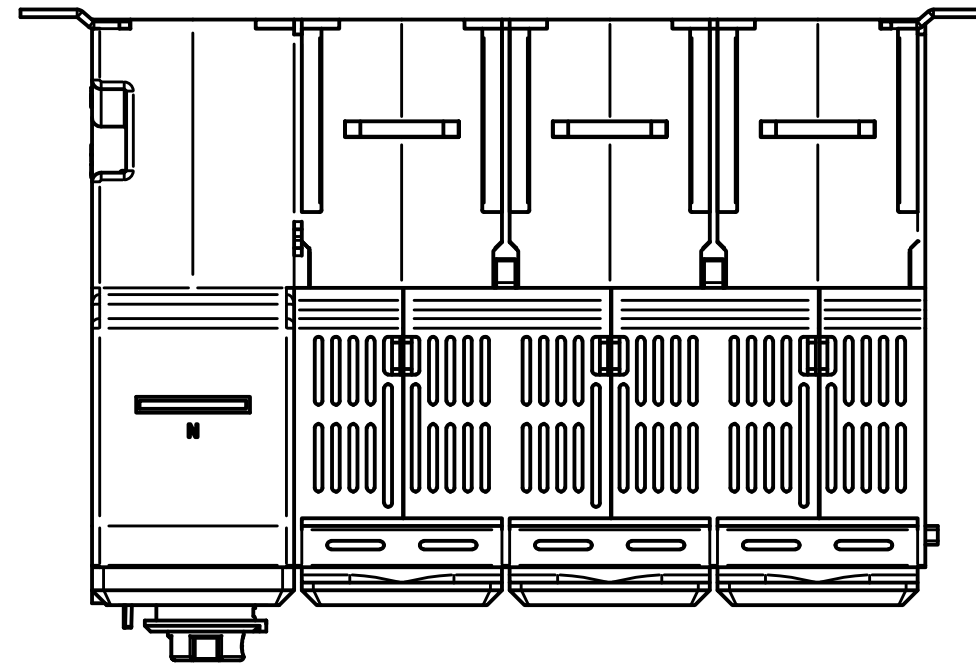

3 \varnothing	Vac	240	480	600
MAX	HP	50	100	125
STD	HP	25	50	60

Suitable for use on a circuit capable of delivering not more than 200kA R.M.S symmetrical, 600V max. Use class J fuses.

Max. fuse size **200A**

The starting current of motors of more than the standard horsepower ratings may require the use of fuses with appropriate time-delay characteristics.

Continuous load current not to exceed 80 percent of the rating of the fuses employed in other than motor circuits.

Not for use as a motor controller.

Use accessories according to instructions: 45672011

MADE IN SPAIN

DETAIL "A"
SIDE PRINTING

1	NO	COMPONENT NO	DESCRIPTION	QTY/M	U/M
BILL OF MATERIAL					
<S>	CRITICAL CHARACTERISTIC FOR PART SAFETY/COMPLIANCE				
●	DENOTES CRITICAL CHARACTERISTICS.				
CPK	DENOTES CPK DIMENSIONS, -MINIMUM CPK VALUE				
(ST)	DENOTES A CHARACTERISTIC THAT PROVIDES AN INDICATION OF PROCESS PERFORMANCE. PROCEDURE FOR MEASUREMENT AND TRACKING TO BE DEFINED IN LITTELFUSE INSPECTION INSTRUCTIONS.				
CP	DENOTES CP DIMENSIONS, -MINIMUM CP VALUE MUST BE WITHIN THE DIMENSIONAL LIMITATIONS SHOWN ON DRAWING AND INITIALLY LOCATED TO ALLOW FOR MAXIMUM TOOL LIFE.				
MATL SPEC			FINISH		
DRW	DATE	SCALE	FINISH GOOD WT		
myork	1/5/2023	NTS	GRAMS/PIECE		
UNLESS OTHERWISE SPECIFIED, DIMENSIONS ARE IN MILLIMETERS, DIMENSIONS IN BRACKETS [] ARE INCHES DIMENSIONING AND DO NOT INCLUDE PLATING. TOLERANCING TO BE INTERPRETED IN ACCORDANCE WITH ANSI Y14.5M-1994					
3RD ANGLE PROJECTION					
TITLE CLASS J 200A DISCONNECT 3P OUTLINE					
Littelfuse® CHICAGO, ILLINOIS 60631			REVISION	DRWG NO.	SHEET 1 OF 1
			B	OL-LM32003PJ	