

MPS MANUAL

MOTOR PROTECTION SYSTEM

Revision 6-F-022117

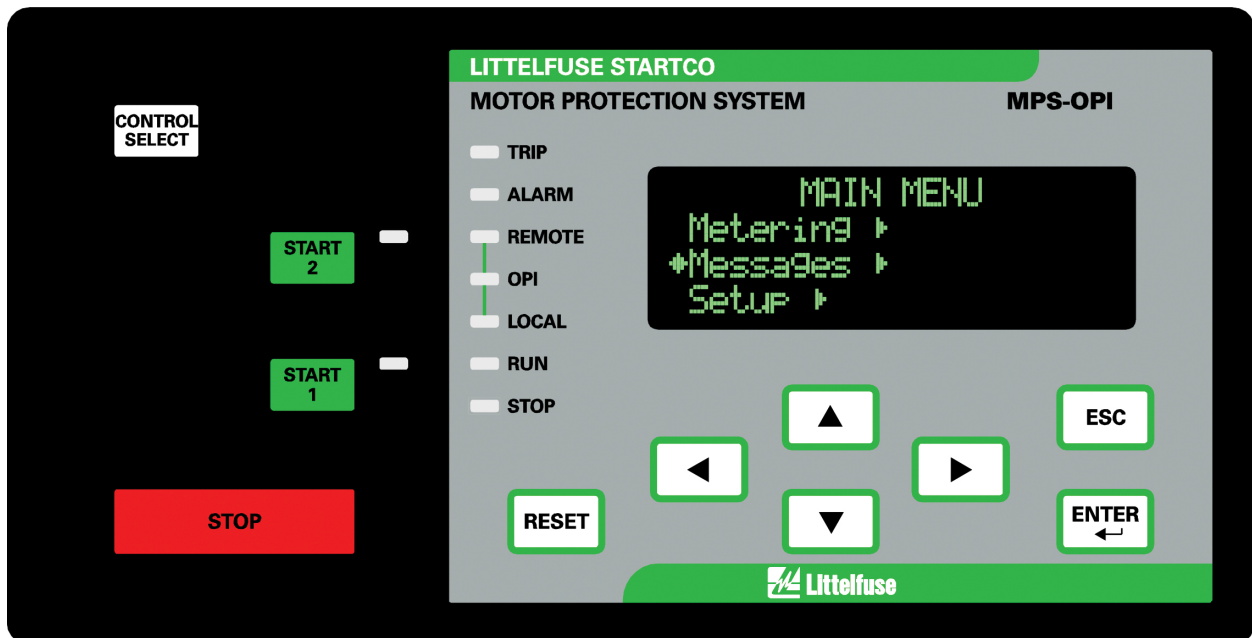

Copyright © 2017 by Littelfuse Startco

All rights reserved.

Factory default password is 1111

New Password

See Section 4.3.6.

Motor Identification

TABLE OF CONTENTS

SECTION	PAGE	SECTION	PAGE
List of Figures	iv		
List of Tables	iv		
Disclaimer	v		
1 Introduction	1-1		
1.1 General	1-1		
1.2 MPS Features	1-1		
1.2.1 Protection	1-1		
1.2.2 Control – Starting Methods	1-1		
1.2.3 Metering	1-1		
1.2.4 Data Logging	1-1		
1.2.5 Inputs and Outputs	1-1		
1.2.6 MPS-OPI Operator Interface	1-2		
1.2.7 MPS-RTD Module	1-2		
1.2.8 MPS-DIF Differential Module	1-2		
1.2.9 Communications Interface	1-2		
1.3 Ordering Information	1-2		
2 Installation	2-1		
2.1 General	2-1		
2.2 MPS-CTU Control Unit	2-1		
2.3 MPS-OPI Operator Interface	2-1		
2.4 MPS-RTD Module	2-1		
2.5 MPS-DIF Differential Module	2-1		
2.6 Earth-Fault CT's	2-1		
3 System Wiring	3-1		
3.1 General	3-1		
3.2 Wiring Connections	3-1		
3.2.1 MPS-CTU Connections	3-1		
3.2.1.1 Supply Voltage	3-1		
3.2.1.2 Current Inputs	3-1		
3.2.1.3 Voltage Inputs	3-1		
3.2.1.3.1 Direct Connection	3-3		
3.2.1.3.2 1-PT Connection	3-3		
3.2.1.3.3 2-PT Connection	3-3		
3.2.1.3.4 3-PT Connection	3-3		
3.2.1.4 Digital Inputs	3-3		
3.2.1.4.1 DC Operation	3-4		
3.2.1.4.2 AC Operation	3-4		
3.2.1.4.3 Combined AC and DC Operation	3-4		
3.2.1.4.4 Tachometer Input (HSI)	3-4		
3.2.1.5 Analog Input (AN IN)	3-4		
3.2.1.6 Analog Output (AN OUT)	3-4		
3.2.1.7 PTC Input	3-4		
3.2.1.8 IRIG-B Input	3-4		
3.2.1.9 I/O Module Communication	3-4		
3.2.1.10 RS-485 Network Communications	3-4		
3.2.2 MPS-OPI Connections and Address Selection	3-4		
3.2.3 MPS-RTD Connections and Address Selection	3-5		
3.2.4 MPS-DIF Connections	3-5		
3.2.4.1 Core Balance	3-5		
		3.2.4.2 MPS Summation	3-5
		3.2.4.3 DIF Summation	3-5
		3.2.5 Dielectric-Strength Testing	3-5
4 Operation and Setup	4-1		
4.1 General	4-1		
4.2 MPS-CTU	4-1		
4.2.1 LED Indication	4-1		
4.2.2 Reset Switch	4-1		
4.2.3 Phase-CT Inputs	4-1		
4.2.4 Earth-Fault-CT Input	4-2		
4.2.5 Voltage Inputs	4-2		
4.2.6 Motor Data	4-2		
4.2.7 Output Relay Assignment	4-2		
4.2.8 Digital Inputs 1 to 7	4-3		
4.2.9 Tachometer Input (HSI)	4-4		
4.2.10 Analog Output	4-4		
4.2.11 Analog Input	4-5		
4.2.11.1 Metering only	4-5		
4.2.11.2 Protection	4-5		
4.2.11.3 Synchronize to ASD	4-5		
4.2.11.4 Motor Speed	4-5		
4.2.12 Starter	4-5		
4.2.13 Protection	4-5		
4.2.14 Miscellaneous Configuration	4-5		
4.2.15 Network Communications	4-5		
4.3 MPS-OPI	4-5		
4.3.1 General	4-5		
4.3.2 Configuring the MPS-CTU for OPI Operation	4-5		
4.3.3 Starter Control	4-6		
4.3.3.1 OPI Control	4-6		
4.3.3.2 Local Control	4-6		
4.3.3.3 Remote Control	4-6		
4.3.4 Metering	4-7		
4.3.5 Messages	4-7		
4.3.5.1 Trip Reset	4-7		
4.3.5.2 Status	4-7		
4.3.5.3 Data Logging	4-9		
4.3.5.4 Statistical Data	4-9		
4.3.5.5 Emergency Thermal Reset	4-9		
4.3.6 Password Entry and Programming	4-9		
4.4 MPS-RTD	4-10		
4.5 MPS-DIF	4-10		
4.6 Waveform Capture	4-10		
5 Protective Functions	5-1		
5.1 General	5-1		
5.2 Overload	5-1		
5.2.1 Thermal Model	5-1		
5.2.2 Locked-Rotor Times	5-4		
5.2.3 Emergency Thermal Reset	5-4		
5.3 Overcurrent	5-4		
5.4 Auxiliary Overcurrent	5-5		
5.5 Reduced Overcurrent	5-5		
5.6 Jam	5-5		
5.7 Earth Fault	5-5		

SECTION	PAGE	SECTION	PAGE
5.8	5-5	8.2	8-1
5.9	5-6	8.2.1	8-1
5.10	5-6	8.2.2	8-1
5.11	5-6	8.2.3	8-1
5.12	5-6	8.2.4	8-1
5.13	5-6	9	9-1
5.14	5-6	9.1	9-1
5.15	5-6	9.2	9-3
5.16	5-7	9.3	9-3
5.17	5-7	9.4	9-4
5.18	5-7	10	9-5
5.19	5-7	Appendix A	A-1
5.20	5-7	Appendix B	B-1
5.21	5-7	Appendix C	C-1
5.22	5-8	Appendix D	D-1
5.23	5-8	Appendix E	E-1
5.24	5-8	Appendix F	F-1
5.25	5-9	Appendix G	G-1
5.26	5-9		
5.27	5-9		
5.28	5-10		
5.29	5-10		
5.29.1	5-10		
5.29.2	5-10		
5.29.3	5-10		
5.29.4	5-10		
6	6-1		
6.1	6-1		
6.2	6-4		
6.3	6-7		
6.4	6-7		
6.5	6-7		
6.6	6-8		
6.7	6-8		
6.8	6-10		
6.9	6-10		
6.10	6-11		
6.11	6-12		
6.12	6-12		
6.13	6-12		
6.14	6-12		
6.15	6-13		
6.16	6-13		
7	7-1		
7.1	7-1		
7.2	7-1		
7.3	7-1		
7.4	7-1		
7.5	7-1		
7.6	7-1		
8	8-1		
8.1	8-1		
8.1.1	8-1		
8.1.2	8-1		

LIST OF FIGURES

FIGURE	PAGE	FIGURE	PAGE
1.1	1-3	6.12	6-8
1.2	1-4	6.13	6-8
2.1	2-2	6.14	6-9
2.1.1	2-3	6.15	6-9
2.2	2-4	6.16	6-10
2.3	2-5	6.17	6-10
2.3.1	2-6	6.18	6-11
2.4	2-7	6.19	6-12
2.5	2-8	6.20	6-13
2.6	2-9	6.21	6-14
2.7	2-10	6.22	6-14
2.8	2-11	6.23	6-15
2.9	2-12		
2.10	2-13		
2.11	2-14		
2.12	2-15		
3.1	3-1		
3.2	3-2		
3.3	3-3		
3.4	3-3		
3.5	3-3		
3.6	3-3		
3.7	3-4		
3.8	3-5		
3.9	3-6		
3.10	3-7		
3.11	3-8		
3.12	3-8		
3.13	3-9		
4.1	4-1		
4.2	4-1		
4.3	4-6		
5.1	5-3		
5.2	5-5		
5.3	5-10		
6.1	6-3		
6.2	6-4		
6.3	6-4		
6.4	6-4		
6.5	6-5		
6.6	6-5		
6.7	6-6		
6.8	6-6		
6.9	6-7		
6.10	6-7		
6.11	6-7		

LIST OF TABLES

TABLE	PAGE
3.1	3-4
3.2	3-5
4.1	4-2
4.2	4-3
4.3	4-4
4.4	4-8
4.5	4-8
5.1	5-4
5.2	5-4
6.1	6-1
6.2	6-3

DISCLAIMER

Specifications are subject to change without notice. Littelfuse Startco is not liable for contingent or consequential damages, or for expenses sustained as a result of incorrect application, incorrect adjustment, or a malfunction.

1. INTRODUCTION

1.1 GENERAL

The Littelfuse Startco Motor Protection System (MPS) is a modular system with integrated protection, control, metering, and data-logging functions. The Control Unit (MPS-CTU) is the core module. It can operate as a stand-alone unit or with the Operator Interface (MPS-OPI), RTD Modules (MPS-RTD), and Differential Module (MPS-DIF). The CTU can be programmed using the OPI or the communications network. Programmable inputs and outputs provide a flexible hardware platform and custom software can be easily loaded from a PC to the CTU's flash memory. The MPS block diagram is shown in Fig. 1.1.

1.2 MPS FEATURES

1.2.1 PROTECTION

- Overload (49, 51)
- Overcurrent (50, 51)
- Earth fault (50G/N, 51G/N)
- Unbalance (voltage and current) (46, 47)
- Phase loss (voltage and current) (46, 47)
- Phase reverse (voltage and current) (46, 47)
- Jam
- Undercurrent (37)
- Failure to accelerate
- Underspeed (14)
- Overvoltage (59)
- Undervoltage (27)
- Underpower (37)
- Reversepower (32)
- Power factor (55)
- Overfrequency (81)
- Underfrequency (81)
- PTC overtemperature (49)
- RTD temperature (38, 49)
- Starts per Hour (66)
- Differential (87)

1.2.2 CONTROL—STARTING METHODS ⁽¹⁾

- Non-reversing
 - Reversing
 - Soft start
 - Soft start with bypass
 - Adjustable-speed drive
 - Two speed
 - Wye-delta (open or closed transition)
 - Reactor (open or closed transition)
 - Resistor (open or closed transition)
 - Autotransformer
 - Part winding
 - Slip ring
 - Two winding
 - Double delta
- ⁽¹⁾ Only three CT's required for all starting methods.

1.2.3 METERING

- Line currents
- Current unbalance
- Positive-sequence current
- Negative-sequence current
- Earth-leakage current
- Differential currents
- Line-to-line voltages
- Line frequency
- Voltage unbalance
- Positive-sequence voltage
- Negative-sequence voltage
- Power
 - Apparent, Reactive, Real, and Power factor
- Energy
 - kWh, kVAh, and kVARh
- Used thermal capacity
- Thermal trend
- Motor speed
- RTD temperatures
- Analog input and output

1.2.4 DATA LOGGING

- Sixty-four records
 - Date and time of event
 - Event type
 - Line currents
 - Current unbalance
 - Earth-leakage current
 - Differential currents
 - Line-to-line voltages
 - Voltage unbalance
 - Thermal capacity
 - Thermal capacity used during starts
 - Start time
 - Analog-input value
 - Frequency
 - Power (P, S, Q, PF)
 - RTD temperatures
- Trip counters
- Running hours
- Waveform Capture
 - 5 seconds of pre-trip waveform data
 - 16 samples per cycle
 - COMTRADE and CSV file generation

1.2.5 INPUTS AND OUTPUTS

- Three ac-current inputs
- Three ac-voltage inputs
- Earth-leakage-current input
- Seven programmable digital (ac/dc) inputs
- 24-Vdc source for digital inputs
- Tachometer (high-speed pulse) input
- 4-20-mA analog input
- 4-20-mA analog output
- PTC thermistor temperature input

- Up to twenty-four RTD inputs
- Five programmable output relays
- Network communications
- IRIG-B time-code input

1.2.6 MPS-OPI OPERATOR INTERFACE

- 4 x 20 vacuum-fluorescent display
- Starter-control keys
- Display-control and programming keys
- LED status indication
- Remote operation up to 1.2 km (4,000')
- Powered by MPS-CTU

1.2.7 MPS-RTD MODULE

- Eight inputs per module
- Individually selectable RTD types
- RTD Voting
- Solid-state multiplexing
- Up to three modules per system
- Remote operation up to 1.2 km (4,000')
- Powered by MPS-CTU

1.2.8 MPS-DIF DIFFERENTIAL MODULE

- 3-CT core-balance connection
- 6-CT summation connection
- Remote operation up to 1.2 km (4,000')
- Powered by MPS-CTU

1.2.9 COMMUNICATIONS INTERFACE

The standard network communication interface is an RS-485 port with Modbus® RTU and A-B® DF1 protocol support. In addition to the standard interface, network communication options include DeviceNet™, Profibus®, Modbus® TCP, and Ethernet/IP.

1.3 ORDERING INFORMATION

See Fig. 1.2 for MPS-CTU, MPS-OPI, MPS-RTD, and MPS-DIF model numbers.

Earth-Fault Current Sensors:

EFCT-1	Earth-Fault CT, 5-A-primary rating, 82 mm (3.2") window
EFCT-1FC.....	Flux Conditioner for EFCT-1, 70 mm (2.7") window
EFCT-2	Earth-Fault CT with Flux Conditioner, 5-A-primary rating, 139 mm (5.5") window
EFCT-26	Earth-Fault CT, 5-A-primary rating, 26 mm (1") window

(All EFCT's include 6 m (19.5') of 22 AWG (0.33 mm²) shielded cable.)

SE-CS30-4	Current Sensor, 30-A-primary rating, c/w Flux Conditioner, 95.0 mm (3.7") window
SE-CS30-5	Current Sensor, 30-A-primary rating, c/w Flux Conditioner, 130.0 mm (5.1") window
SE-CS30-8	Current Sensor 30-A-primary rating, c/w Flux Conditioner, 200.0 mm (7.9") window
SE-CS30-26.....	Current Sensor, 30-A-primary rating, 26 mm (1.0") window
SE-CS30-70	Current Sensor, 30-A-primary rating, 70 mm (2.7") window

Phase CT's..... Protection-Class CT's,
Contact factory

Accessories:

SE-IP65CVR-M.....	Hinged Transparent OPI Cover
SE-485-PP.....	Port-Powered Serial Converter
SE-485-DIN.....	Serial Converter, Industrial, 24 Vdc

Software:

SE-Comm-RIS	PC Communication Software ⁽¹⁾
SE-Flash.....	Firmware Upgrade Software ⁽¹⁾

⁽¹⁾ Available at www.littelfuse.com/relayscontrols.

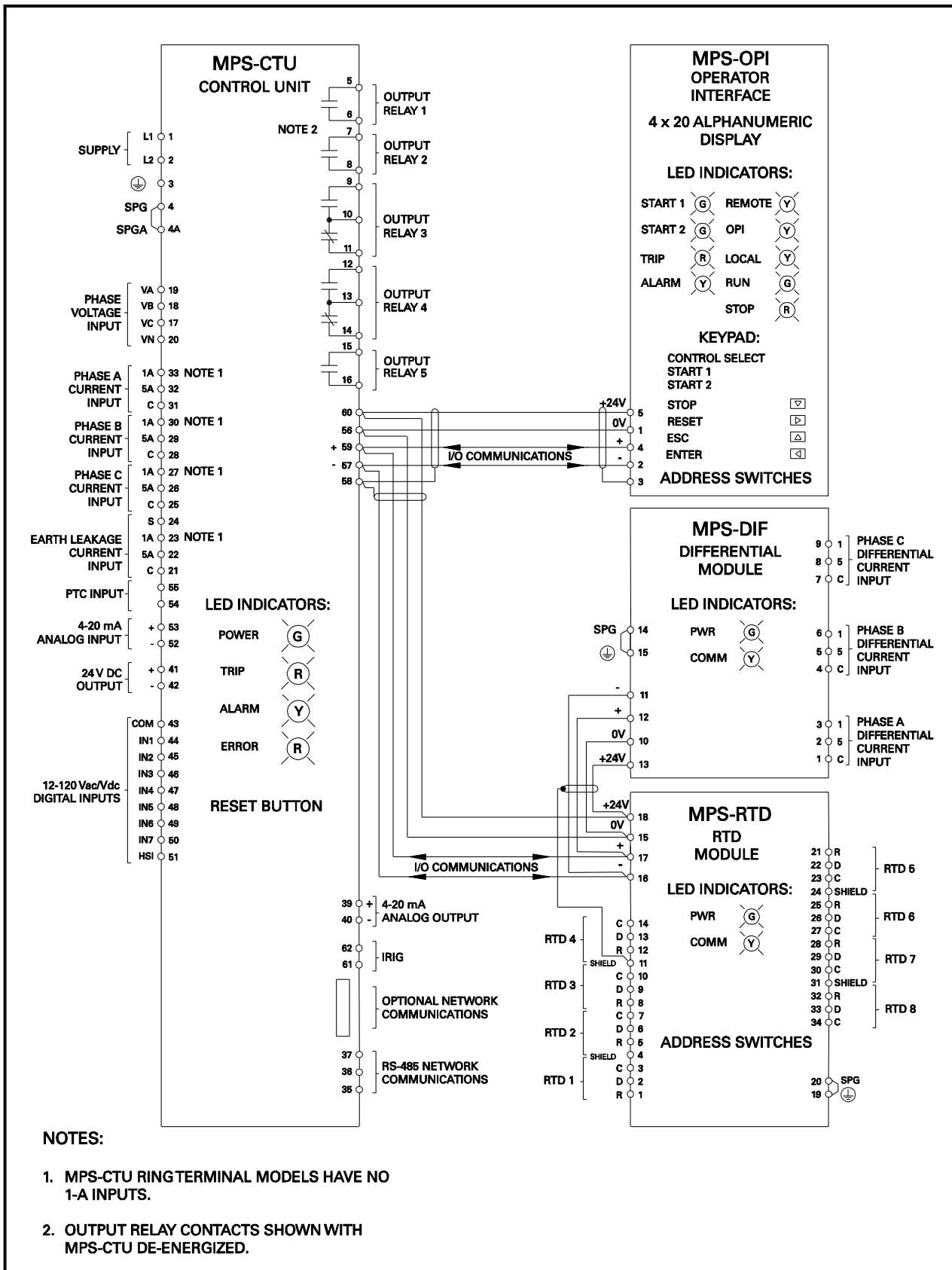

FIGURE 1.1 Motor Protection System Block Diagram.

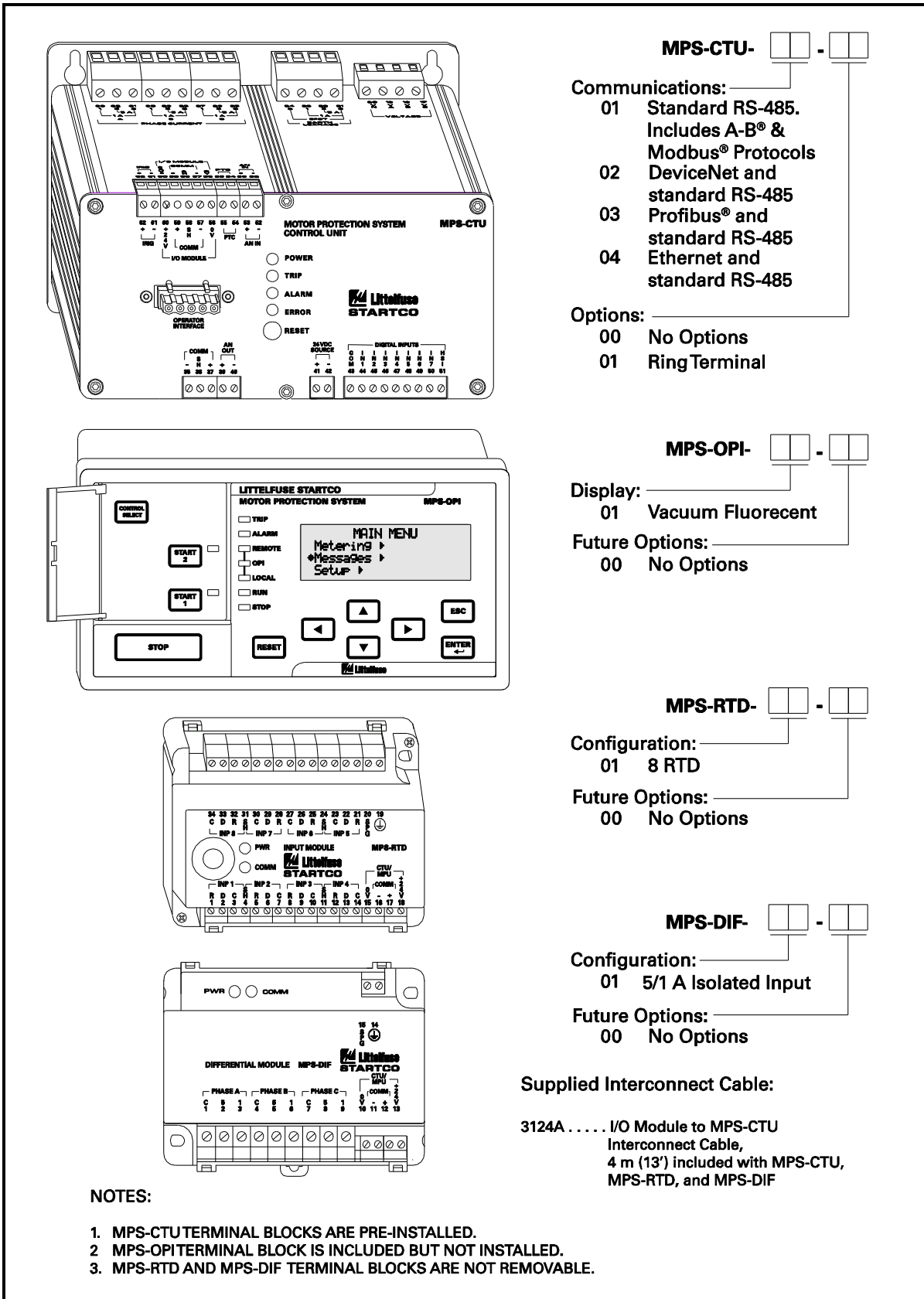

FIGURE 1.2 MPS Ordering Information.

2. INSTALLATION

2.1 GENERAL

A basic Motor Protection System (MPS) consists of an MPS-CTU and three customer-supplied current transformers (CT's) for measuring phase current. For core-balance earth-fault detection, a 1-A, 5-A, EFCT-1, or EFCT-2 CT is required. For the optional Ring Terminal MPS-CTU, the 1-A connection is not available. The residual phase-CT connection can also be used for earth-fault detection. Voltage inputs do not require potential transformers (PT's) for system voltages up to 600 Vac. For RTD-temperature measurement, up to three MPS-RTD modules can be connected to the MPS-CTU. For differential protection, an MPS-DIF module can be connected to the MPS-CTU. The MPS-OPI provides an operator interface for the MPS.

The MPS power-factor-corrected switch-mode power supply is rated 65 to 265 Vac and 80 to 275 Vdc.

All modules can be mounted in any orientation.

2.2 MPS-CTU CONTROL UNIT

The Control Unit is configured for surface mounting. Outline and mounting details for the MPS-CTU are shown in Figs. 2.1 and 2.1.1.

2.3 MPS-OPI OPERATOR INTERFACE

Outline and mounting details for the MPS-OPI are shown in Fig. 2.2. It is certified for use in Class I, Zone 2 and Class I, Division 2 hazardous locations.

The Operator Interface is configured for panel mounting or it can be mounted on the MPS-CTU as shown in Fig. 2.3. The Operator Interface can also be mounted on the MPS-CTU ring terminal as shown in Fig. 2.3.1 (surface mount only).

If an optional SE-IP65CVR-M is used, follow the included installation instructions. See Figs. 2.4 and 2.5.

2.4 MPS-RTD MODULE

Outline and mounting details for the MPS-RTD are shown in Fig. 2.6. The MPS-RTD will fit inside most motor RTD-termination junction boxes and it is certified for use in Class I, Zone 2 and Class I, Division 2 hazardous locations. The MPS-RTD can be surface or DIN-rail mounted.

2.5 MPS-DIF DIFFERENTIAL MODULE

Outline and mounting details for the MPS-DIF are shown in Fig 2.7. The MPS-DIF can be surface or DIN-rail mounted.

2.6 EARTH-FAULT CT'S

Outline and mounting details for the EFCT-1, EFCT-2, EFCT-26, and SE-CS30 series are shown in Figs. 2.8, 2.9, 2.10, 2.11, and 2.12.

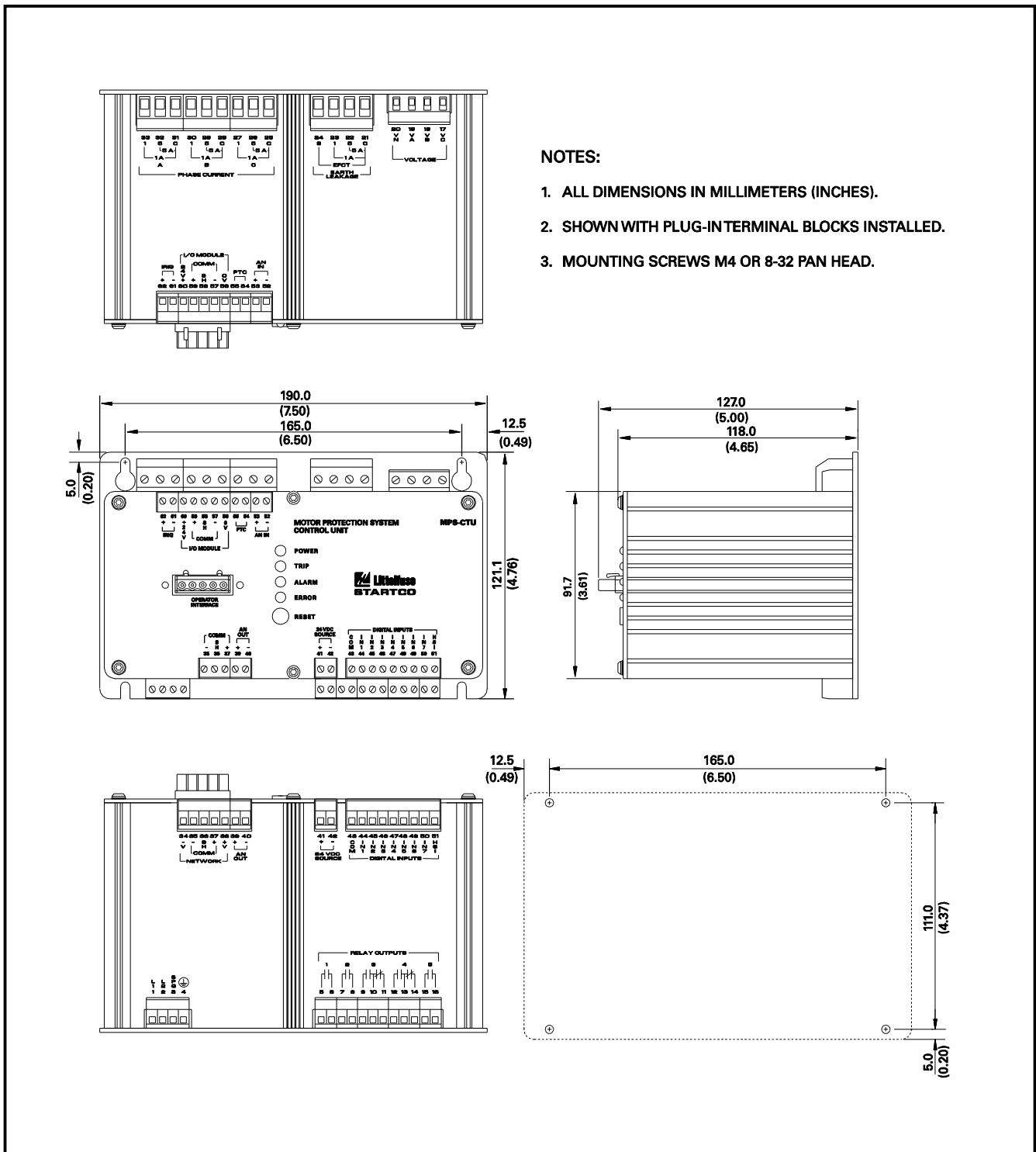

NOTES:

1. ALL DIMENSIONS IN MILLIMETERS (INCHES).
2. SHOWN WITH PLUG-IN TERMINAL BLOCKS INSTALLED.
3. MOUNTING SCREWS M4 OR 8-32 PAN HEAD.

FIGURE 2.1 MPS-CTU Outline and Mounting Details.

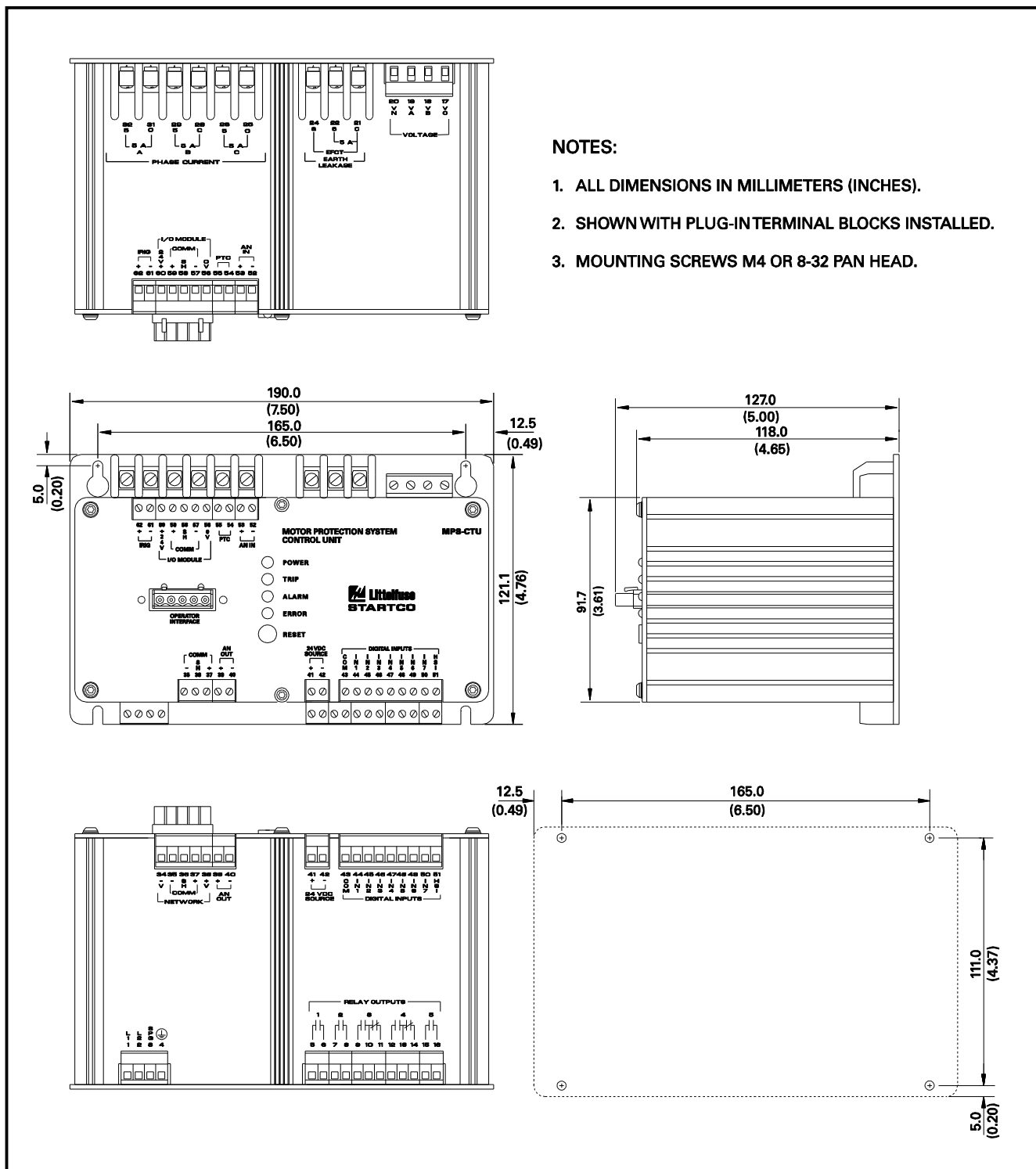

FIGURE 2.1.1 MPS-CTU-XX-X1 Ring Terminal Outline and Mounting Details.

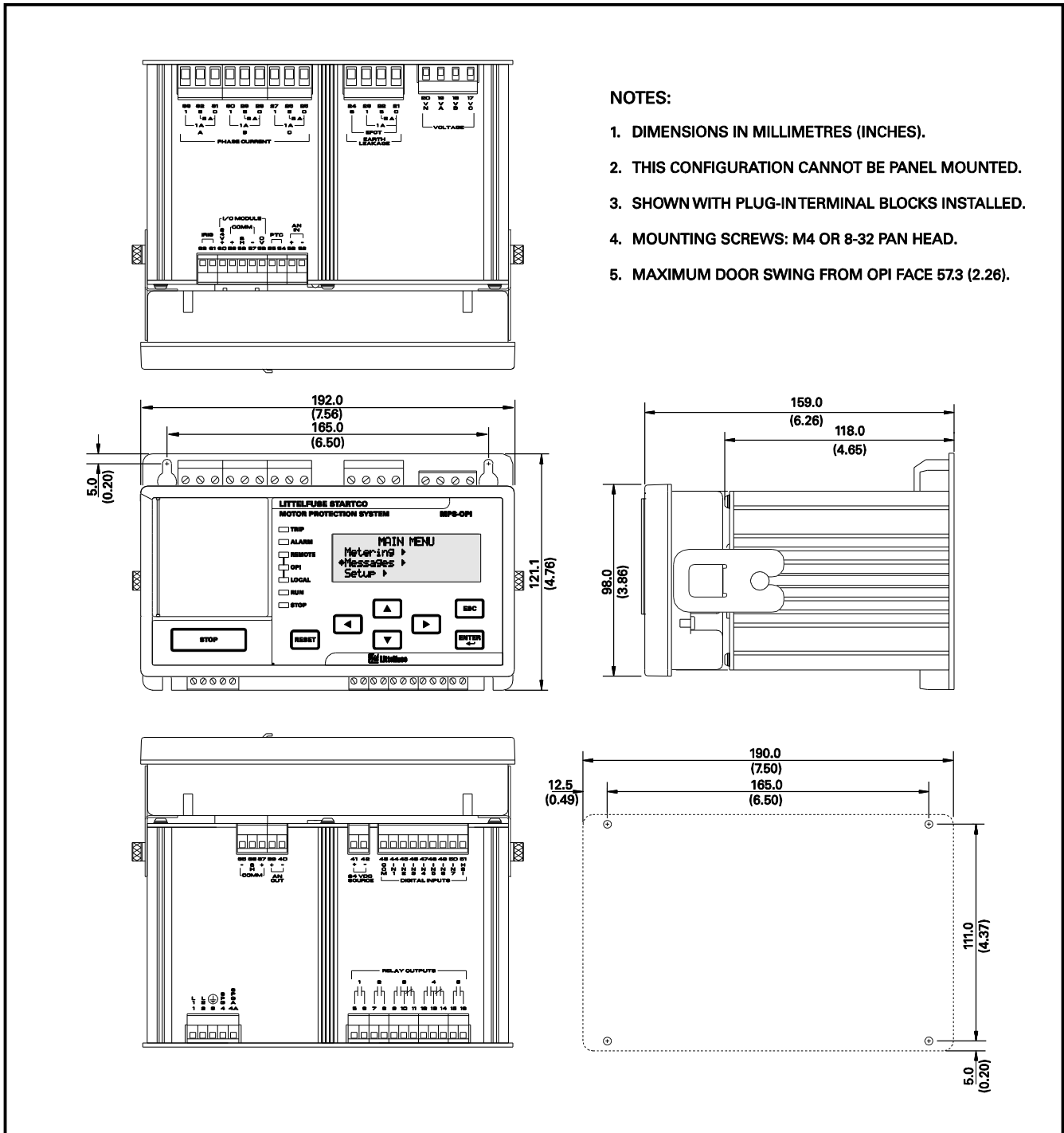

FIGURE 2.3 MPS-CTU with OPI Outline and Mounting Details.

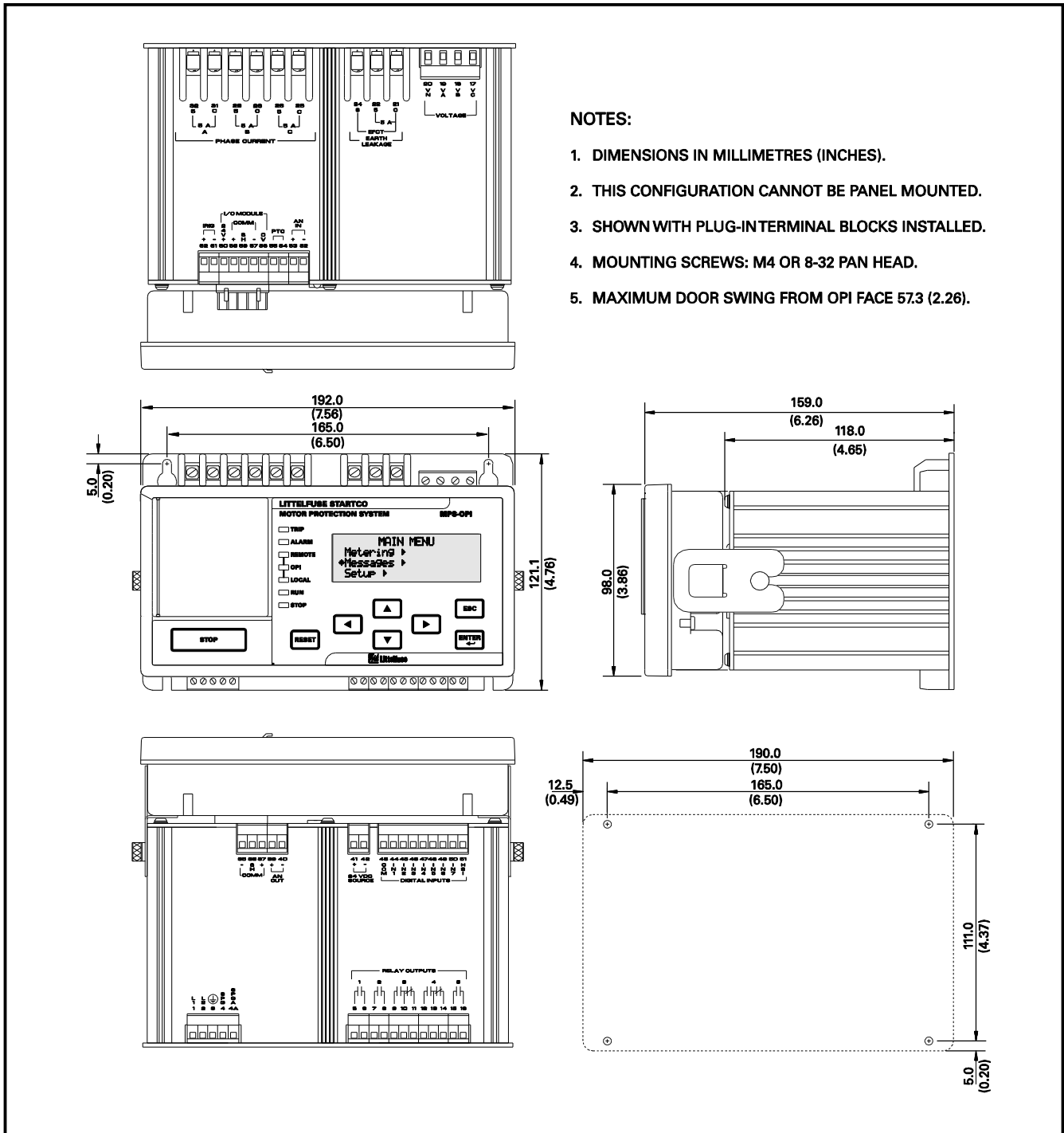

FIGURE 2.3.1 MPS-CTU Ring Terminal with OPI Outline and Mounting Details.

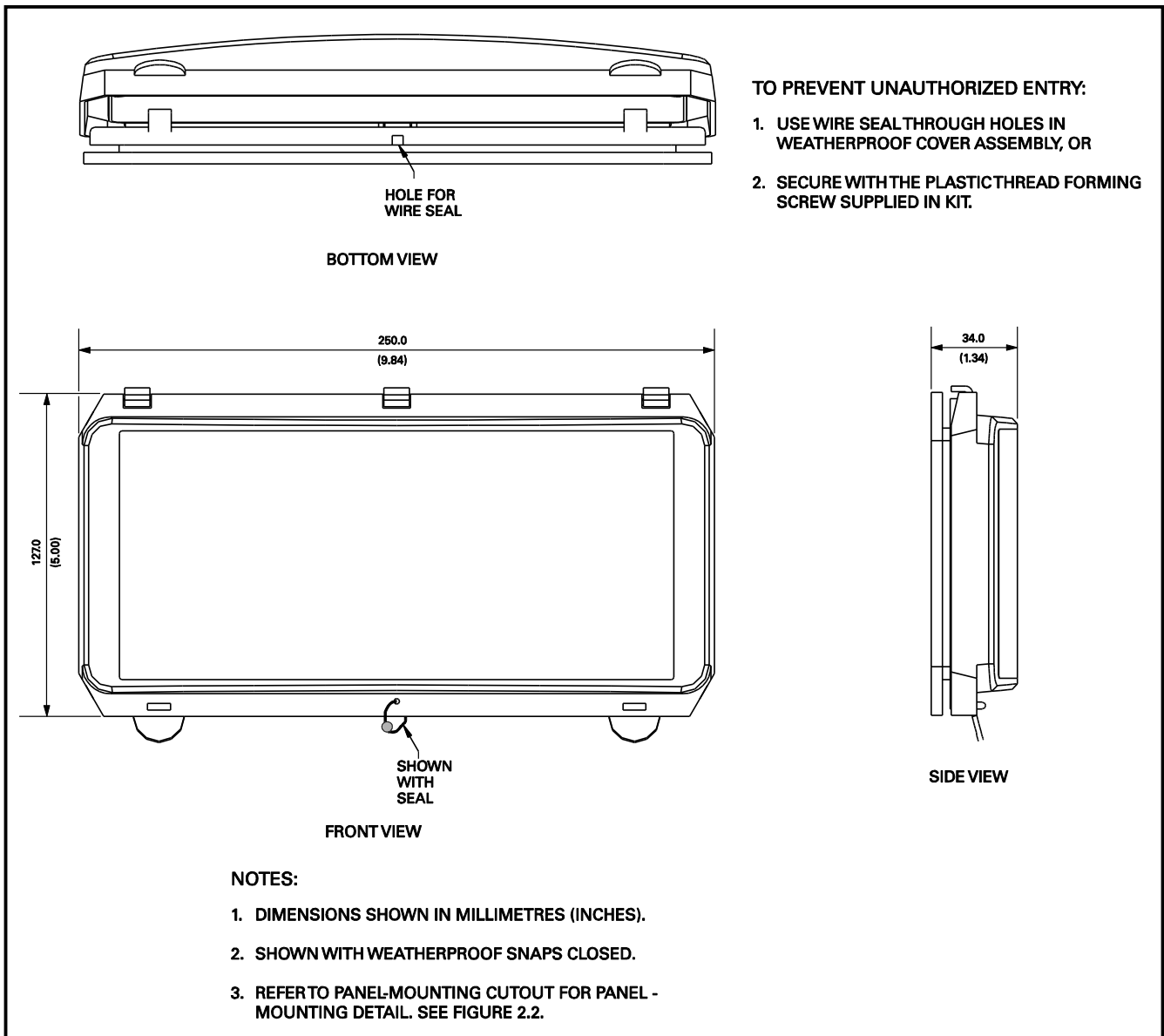

FIGURE 2.4 SE-IP65CVR-M Weatherproof Cover Outline.

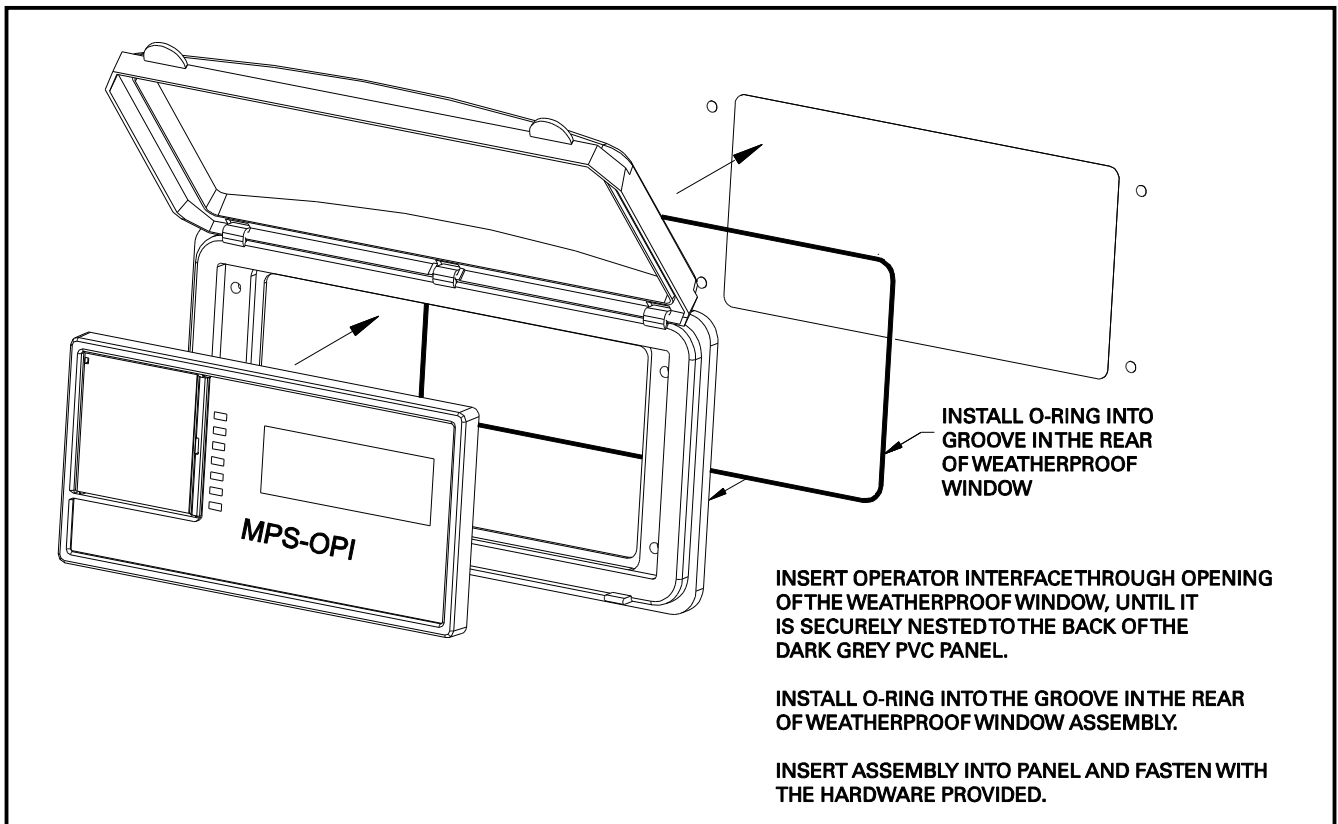

FIGURE 2.5 SE-IP65CVR-M Weatherproof Cover Installation.

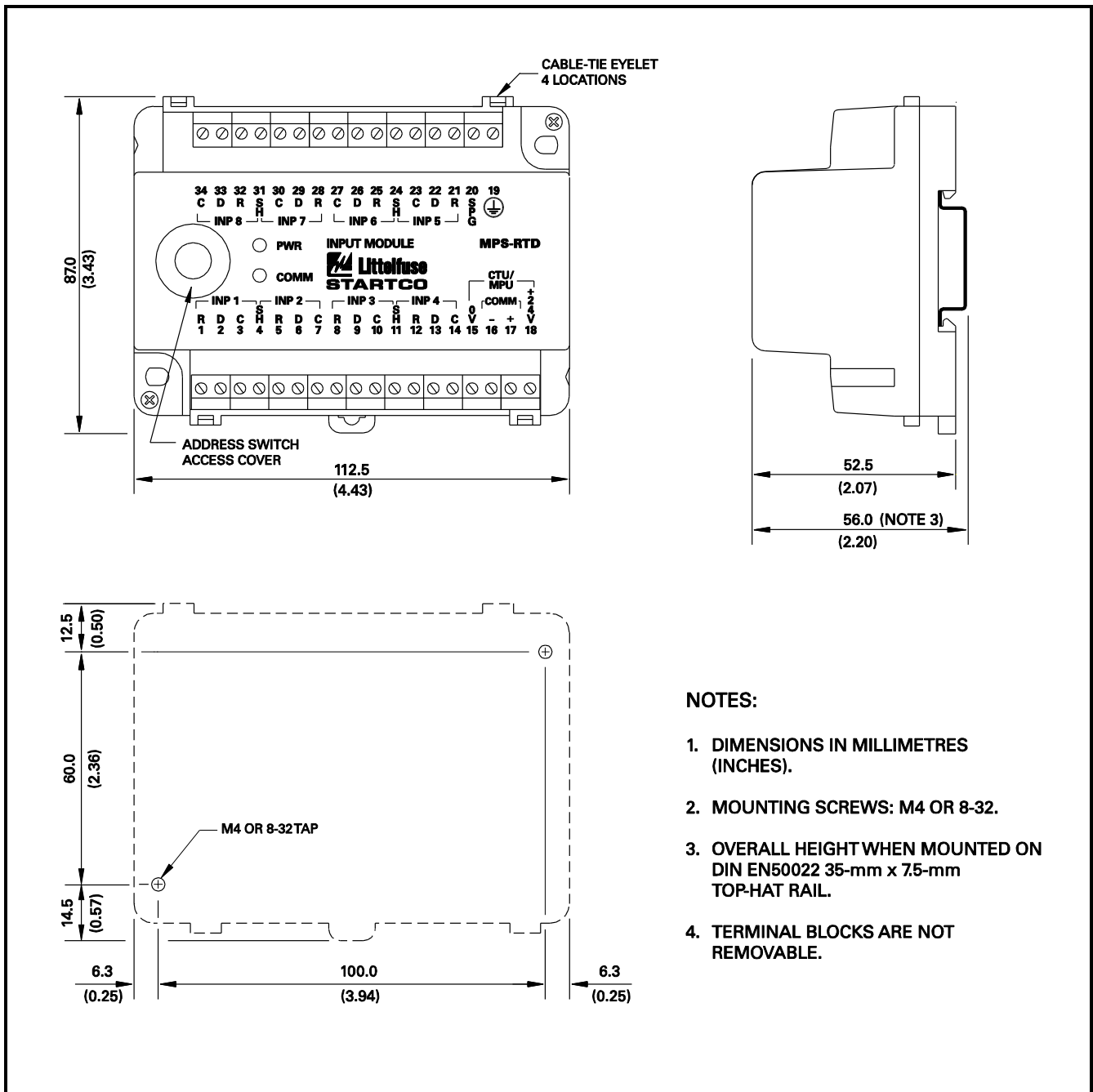

FIGURE 2.6 MPS-RTD Outline and Mounting Details.

NOTES:

1. DIMENSIONS IN MILLIMETRES (INCHES).
2. MOUNTING SCREWS: M4 OR 8-32.
3. OVERALL HEIGHT WHEN MOUNTED ON DIN EN50022 35-mm x 7.5-mm TOP-HAT RAIL.
4. TERMINAL BLOCKS ARE NOT REMOVABLE.

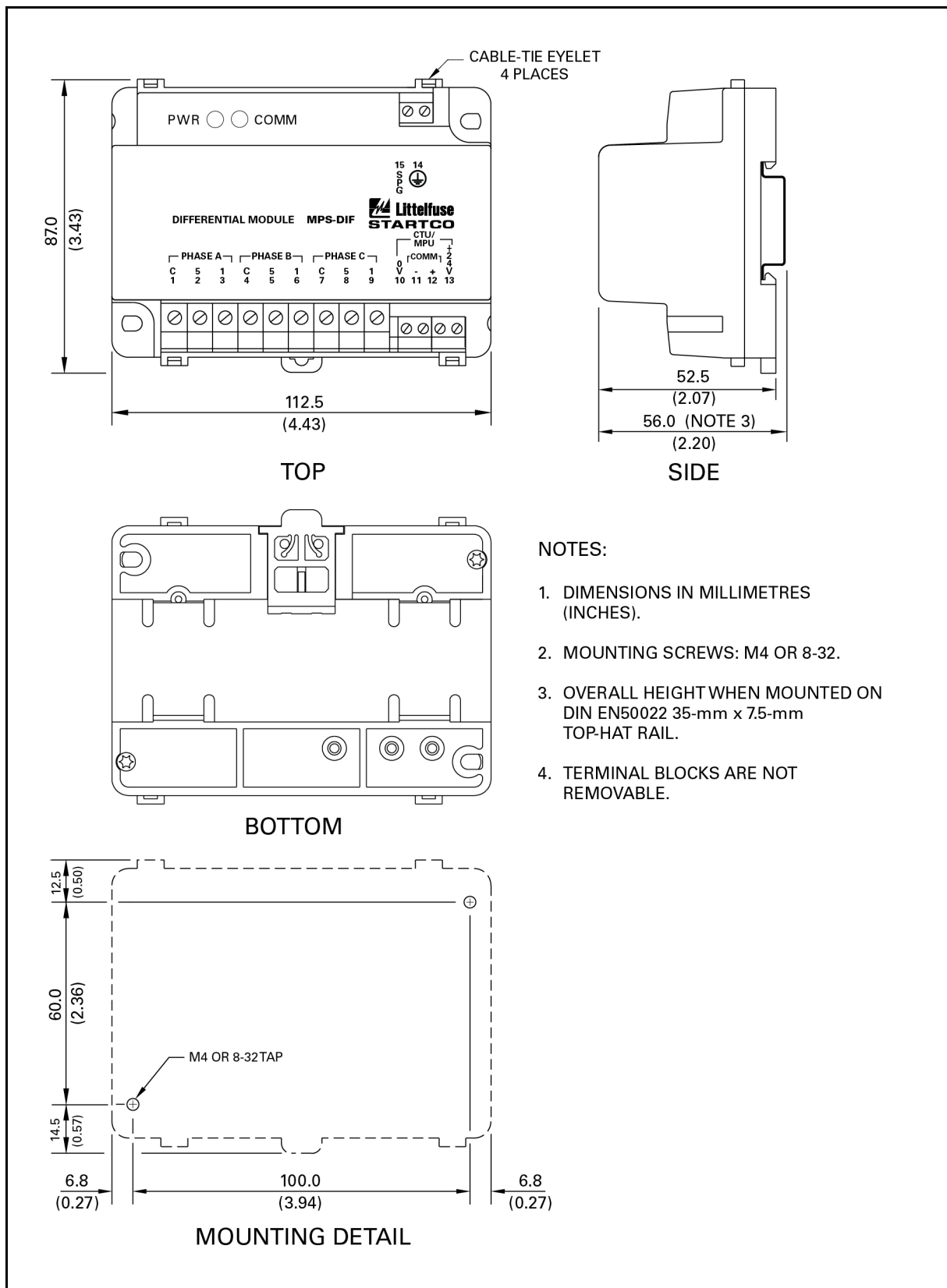

FIGURE 2.7 MPS-DIF Outline and Mounting Details.

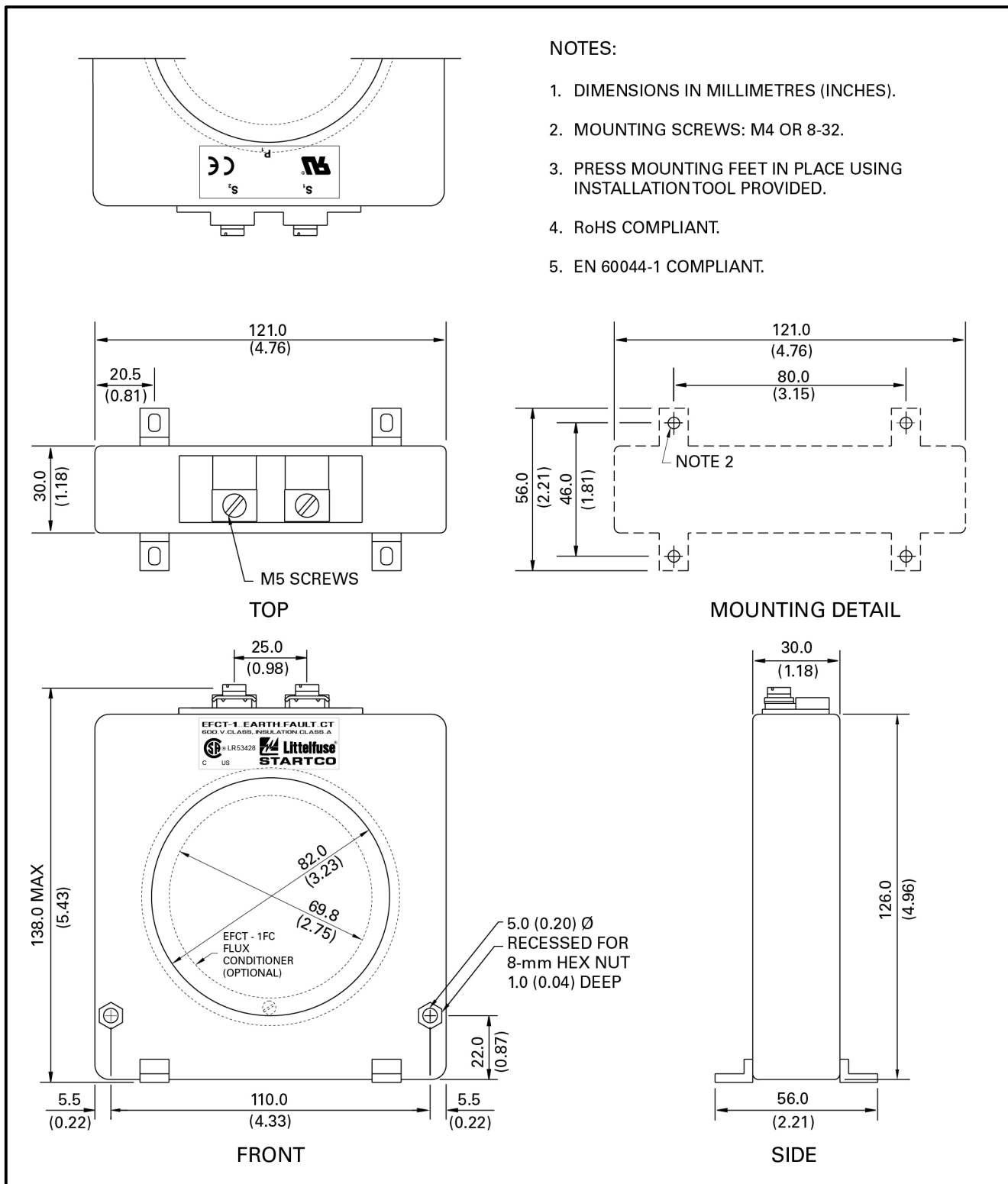

FIGURE 2.8 EFCT-1 Outline and Mounting Details.

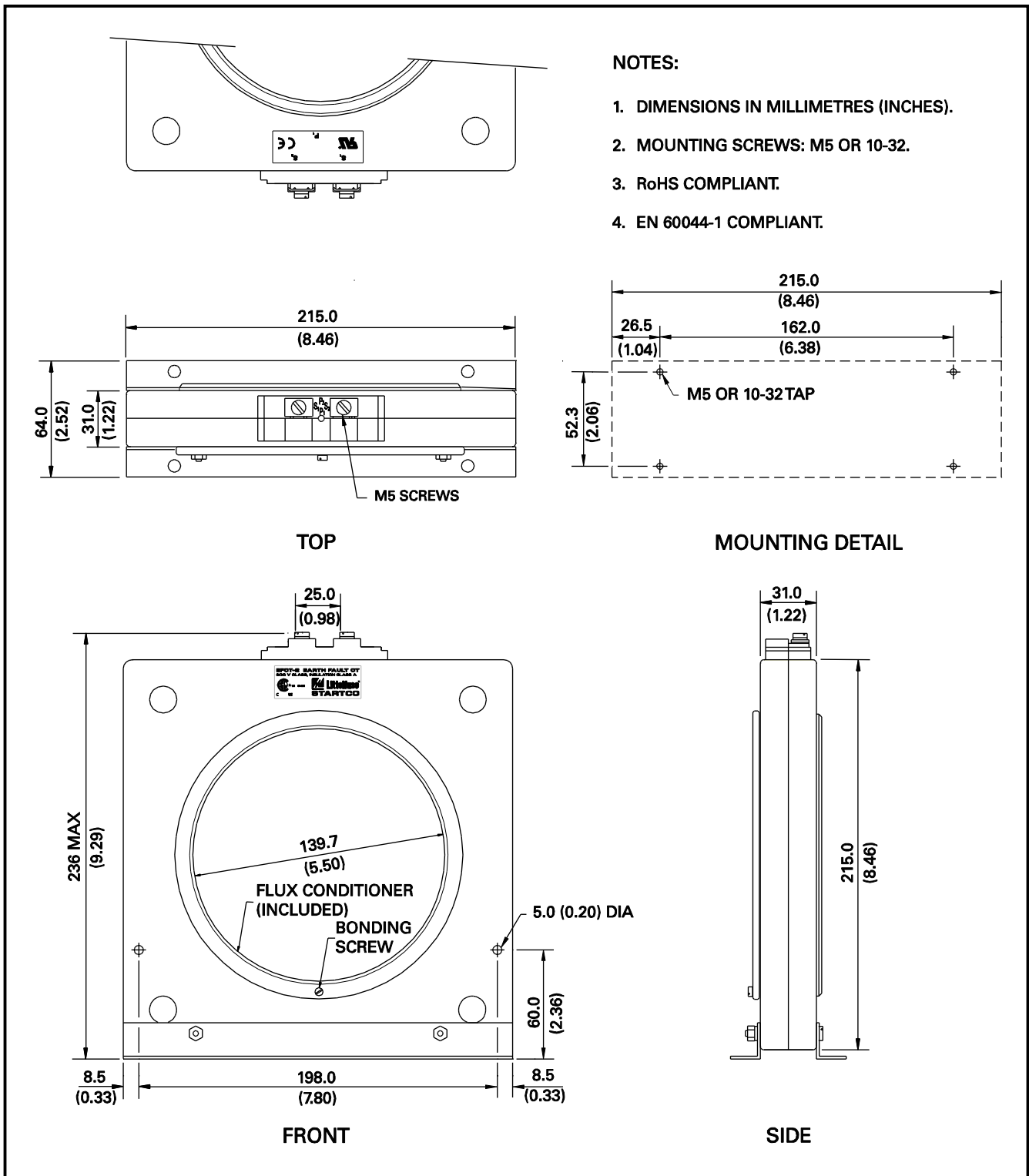

FIGURE 2.9 EFCT-2 Outline and Mounting Details.

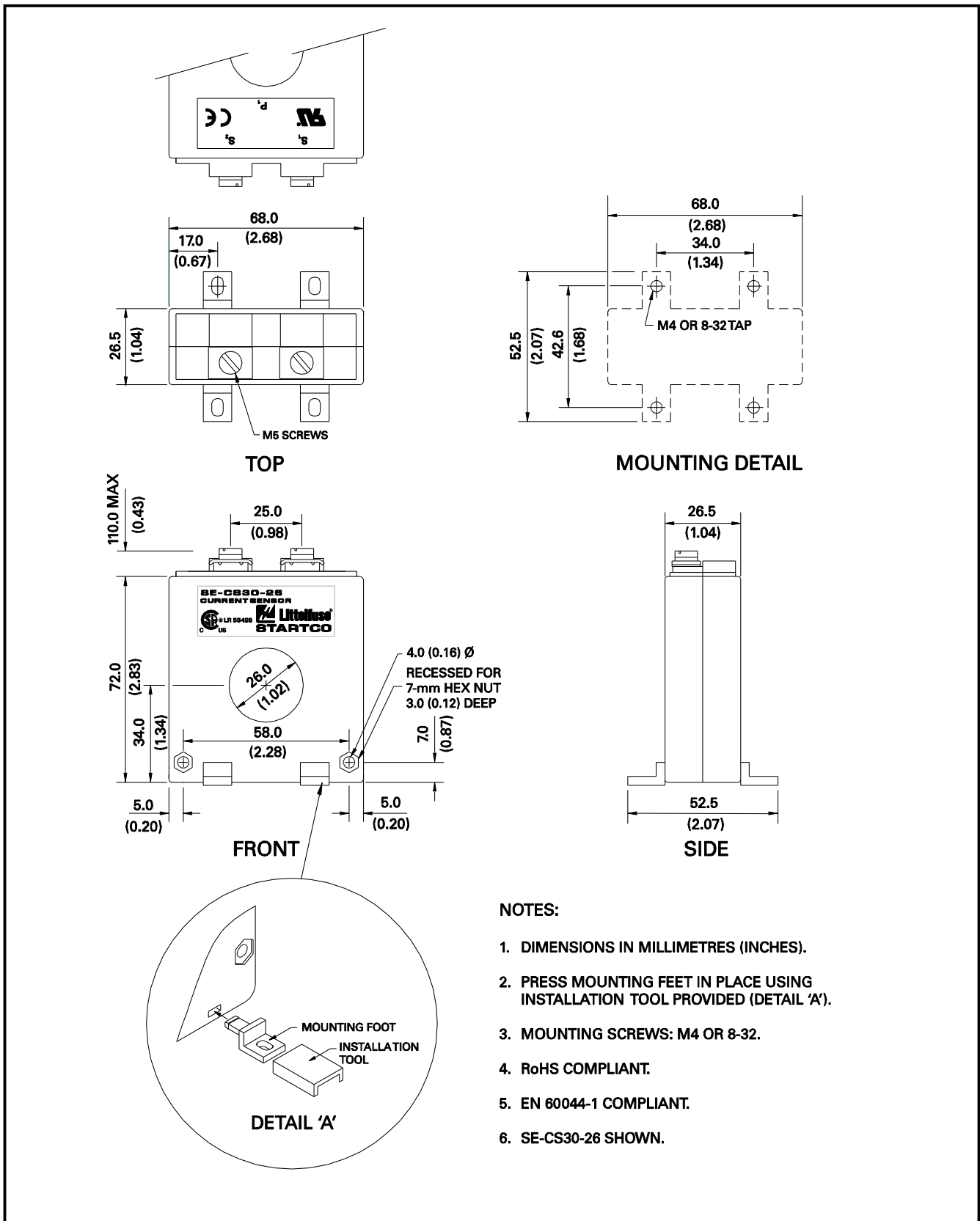

FIGURE 2.10 EFCT-26 and SE-CS30-26 Outline and Mounting Details.

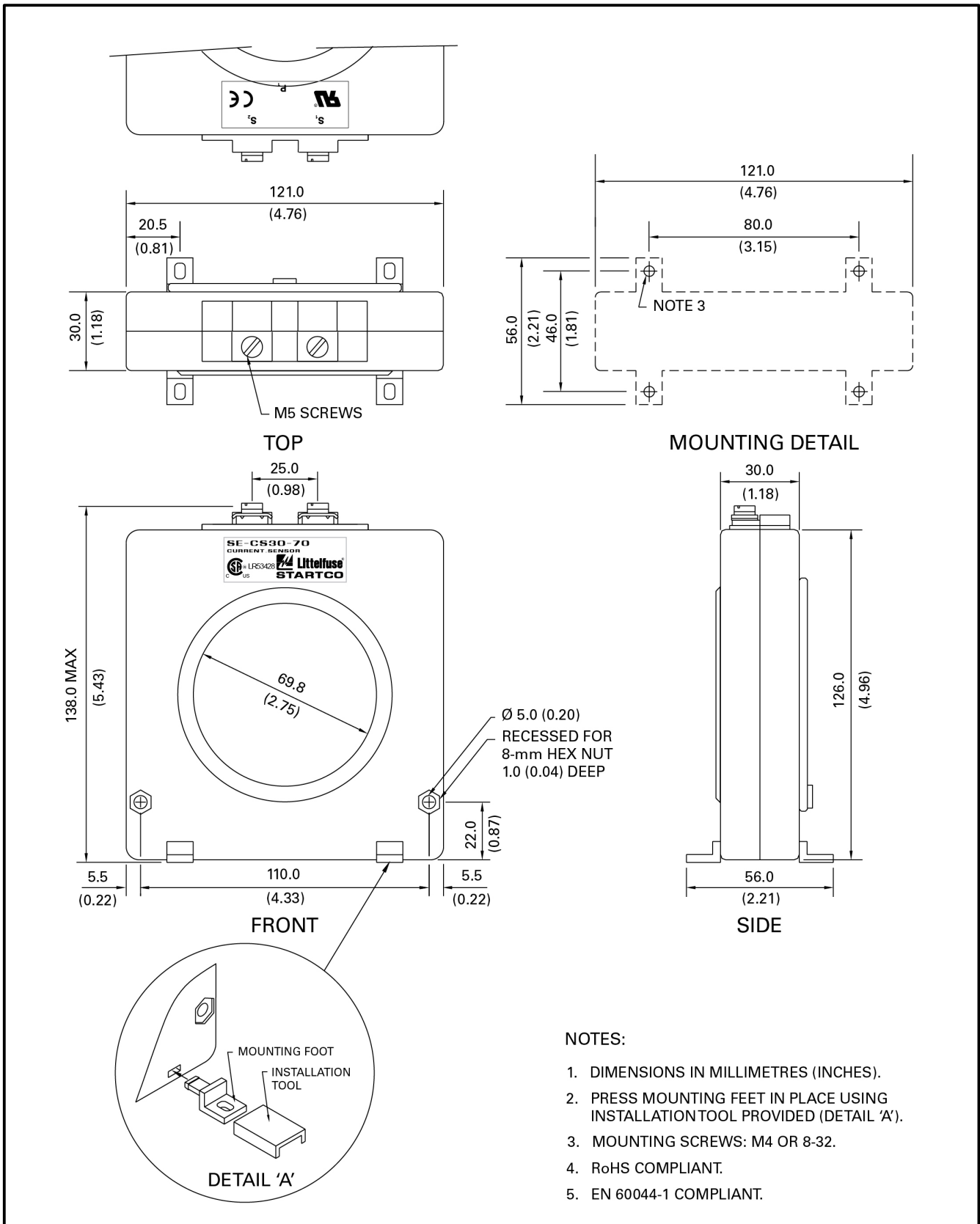

FIGURE 2.11 SE-CS30-70 Outline and Mounting Details.

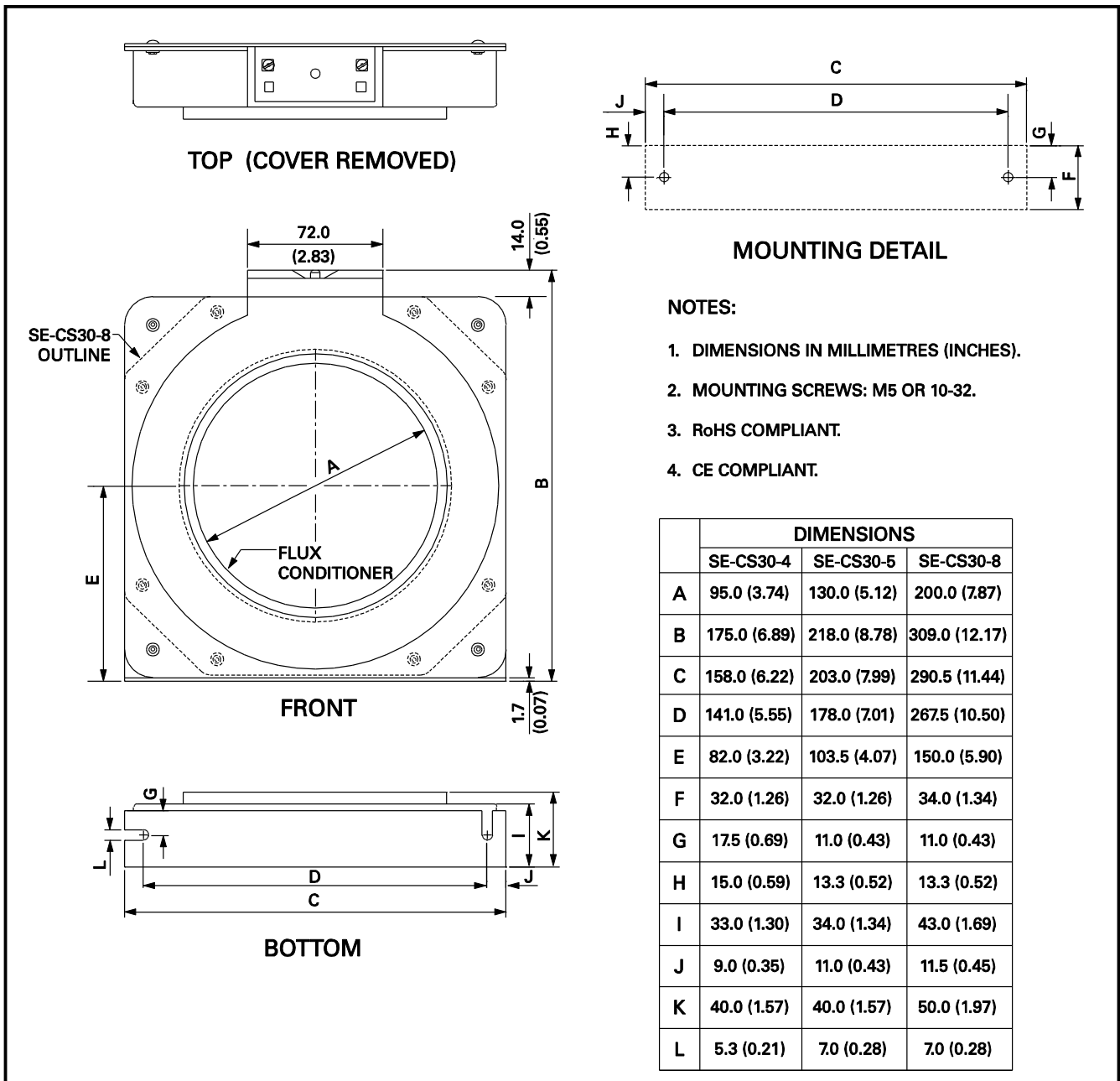

FIGURE 2.12 SE-CS30-4, -5, and -8 Outline and Mounting Details.

This page intentionally left blank.

3. SYSTEM WIRING

3.1 GENERAL

A typical connection diagram is shown in Fig. 3.2. The MPS-CTU provides the 24-Vdc supply for the peripheral modules and it communicates with them using an RS-485 interface. The total length of the I/O communication system must be less than 1.2 km (4,000'). I/O communications addressing supports up to three modules of each type; however, the power supply in the MPS-CTU will not support more than three I/O modules. An external 24-Vdc power supply is required if more than three modules are used.

The MPS-CTU voltage inputs can be directly connected to a system with line-to-line voltages up to 600 Vac. PT's are required for system voltages higher than 600 Vac. Input resistance of the voltage inputs is 3.4 MΩ.

NOTE: The current and voltage inputs must be phase sequenced A-B-C with correct polarity observed.

START1, START2, and STOP starter-control commands can be issued through the digital inputs, the network interface, or the MPS-OPI. Start, stop, and interlock contacts can be wired to any of the programmable digital inputs. The five programmable output relays can be used for starting control, protection, and interlock functions. Relay 5 is a solid-state, low-level output relay not recommended for starter control. See Section 9 for relay ratings.

NOTE: The default configuration has no assignments for digital inputs and relay outputs.

3.2 WIRING CONNECTIONS

3.2.1 MPS-CTU CONNECTIONS

The MPS-CTU CT-input terminal blocks accept 22 to 10 AWG (0.3 to 4.0 mm²) conductors. The remaining MPS-CTU clamping blocks accept 24 to 12 AWG (0.2 to 2.5 mm²) conductors. Terminal blocks unplug to allow the MPS-CTU to be easily replaced.

The MPS-CTU Ring Terminal CT-input terminal block accept a maximum ring width of 8 mm (0.315"). These terminal blocks cannot be unplugged.

3.2.1.1 SUPPLY VOLTAGE

Derive supply voltage from the line side of the motor controller or from an independent source. Connect supply voltage to terminals 1 and 2 (L1 and L2) as shown in Fig. 3.2. In 120-Vac systems, L2 is usually designated as the neutral conductor. For direct-current power supplies, use L1 for the positive terminal and L2 as the negative terminal. Earth terminal 3 (⊕).

Internal surge-protection devices are connected to terminals 4 (SPG) and 4A (SPGA) to allow dielectric-strength testing. Terminals 4 and 4A must be connected except during dielectric-strength testing.

The 24-Vdc I/O module supply (terminals 56 and 60) can support three I/O modules. An external 24-Vdc supply is required if more than three modules are used.

3.2.1.2 CURRENT INPUTS

The MPS-CTU uses 1-A or 5-A CT's for phase-current measurement. The MPS-CTU Ring Terminal uses 5-A CT's for phase-current measurement. To maintain specified accuracy, phase CT's should be protection class and selected with a primary rating between 100 and 300% of motor full-load current (FLA). Current threshold is a function of full-load current and CT-primary rating as defined by the following formula.

$$\text{Current Threshold (\%)} = 1.5 \times \frac{\text{CT Primary Rating}}{\text{FLA}}$$

The Current Threshold is also used to determine when the motor is in Run mode. Several protective functions are only enabled when in Run mode. See Section 5.1 for a description of Run mode.

For synchronous-motor applications, the CT-primary rating should be selected such that the current threshold is less than the idle current, typically less than 5%. All CT inputs can withstand a common-mode voltage of 120 Vac so that the MPS-CTU can be connected in series with other CT loads. The connection diagram in Fig. 3.2 shows a typical connection where the MPS-CTU is the only device connected to the phase CT's. The MPS-CTU requires the phase sequence to be A-B-C with correct polarity.

The I_p Threshold sets the current level where unbalance protection becomes active. See Section 5.8.

A 1-A, 5-A, or sensitive CT is used for core-balance earth-leakage measurement. The MPS-CTU Ring Terminal has no 1-A input. See Fig. 3.1 for the phase-CT residual connection for earth-fault detection.

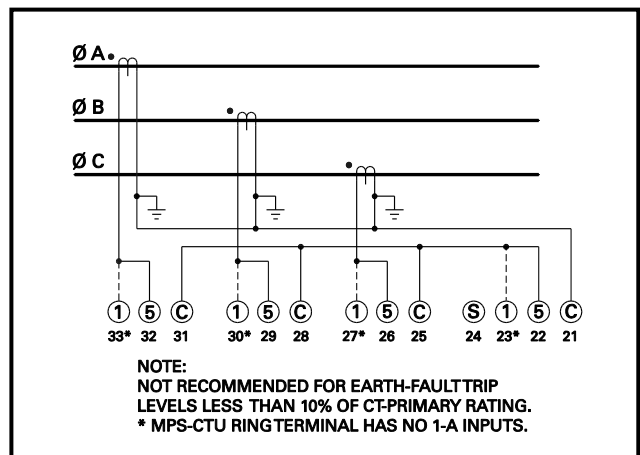

FIGURE 3.1 Residual Phase-CT Connection.

3.2.1.3 VOLTAGE INPUTS

For all input-voltage connections, the MPS-CTU requires the phase sequence to be A-B-C with correct polarity.

If voltage inputs are not used, connect VA, VB, and VC to VN.

NOTE: A voltage input is required for line-frequency metering.

3.2.1.3.1 DIRECT CONNECTION

PT's are not required for system voltages up to 600 Vac line-to-line. Connect the voltage inputs as shown in Figs. 3.2 and 3.3.

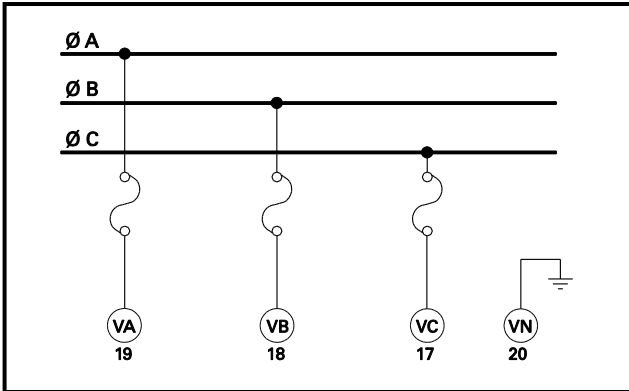

FIGURE 3.3 Direct Connection.

3.2.1.3.2 1-PT CONNECTION

The 1-PT connection is shown in Fig. 3.4. Connect the PT between phase A and phase B. The PT-secondary voltage must be less than 350 Vac.

NOTE: The 1-PT connection does not allow detection of voltage unbalance.

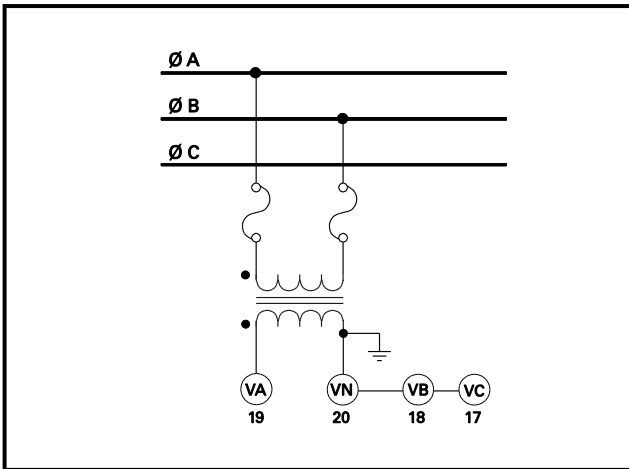

FIGURE 3.4 1-PT Connection.

3.2.1.3.3 2-PT CONNECTION

The 2-PT connection is shown in Fig. 3.5. The PT-secondary voltages must be less than 350 Vac. Connect the PT secondaries in open delta.

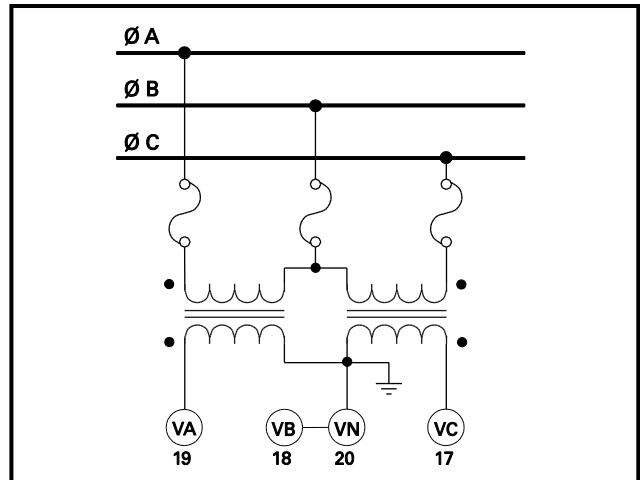

FIGURE 3.5 2-PT Connection.

3.2.1.3.4 3-PT CONNECTION

The 3-PT connection is shown in Fig. 3.6. The PT-secondary voltages must be less than 350 Vac. Since the MPS-CTU measures line-to-line voltage, there is no advantage in using a 3-PT connection over a 2-PT connection.

NOTE: This connection relies on PT primary-magnetization current for voltage balance. Do not connect any other secondary loads.

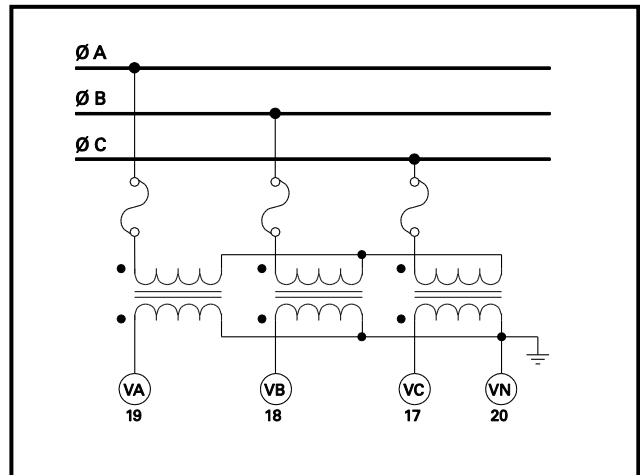

FIGURE 3.6 3-PT Connection.

3.2.1.4 DIGITAL INPUTS

Digital inputs 1 to 8 (terminals 44 to 51) are referenced to COM (terminal 43). These inputs are isolated from all other terminals and operate over a 12 to 120 Vac/Vdc range. Inputs 1 to 7 have programmable functions. See Table 4.2. Input 8 is a high-speed input (HSI) for a tachometer sensor.

3.2.1.4.1 DC OPERATION

Supply voltage for dc-input operation can be obtained from the 24-Vdc source (terminals 41 and 42), or it can be obtained from an external 12- to 120-Vdc supply.

The internal source is current limited at 100 mA and is referenced to the analog output (terminal 40) and the I/O Supply (terminal 56). Connect the “-” terminal of the dc source to COM and connect field inputs between “+” and the digital-input terminals.

3.2.1.4.2 AC OPERATION

Inputs operate over a 12- to 120-Vac range. Connect the ac neutral to COM and connect field inputs between line and the digital inputs.

3.2.1.4.3 COMBINED AC AND DC OPERATION

If both ac and dc inputs are used, connect both the ac-supply common and dc-supply “-” to COM.

3.2.1.4.4 TACHOMETER INPUT (HSI)

A tachometer sensor can be used to provide motor-speed measurement. Connect a logic-output PNP tachometer as shown in Fig. 3.7.

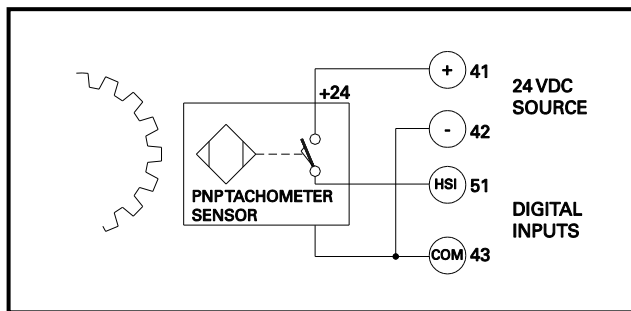

FIGURE 3.7 Digital Tachometer Input (HSI).

3.2.1.5 ANALOG INPUT (AN IN)

The analog input (terminal 52 and 53) is a 4-20-mA current input with a 100-Ω input impedance.

NOTE: The analog input is referenced to an internal supply with 100-kΩ resistors. Maximum common-mode voltage is ± 5 Vdc with respect to MPS-CTU terminal 4.

3.2.1.6 ANALOG OUTPUT (AN OUT)

The analog output is a self-powered current-source output. The current source output is the “+” (terminal 39) and the common is “-” (terminal 40).

NOTE: The analog output (terminal 40) is internally referenced to the 24-Vdc source (terminal 42) and the I/O supply (terminal 56).

3.2.1.7 PTC INPUT

Terminals 54 and 55 are provided for PTC over-temperature protection. See Section 9 for specifications.

3.2.1.8 IRIG-B INPUT

Terminals 61 and 62 are used for an IRIG-B time-code signal. When an IRIG-B signal is detected, the real-time clock (RTC) synchronizes with it. The user must set the MPS date value because the IRIG-B day-of-the-year parameter is not supported.

If the time-code generator does not have a local-time adjustment, the IRIG Offset set points can be used to adjust the hour and minute values so that the MPS will read local time.

3.2.1.9 I/O MODULE COMMUNICATION

The I/O module communications interface (terminals 56 through 60) is used to support optional modules. The connector labeled Operator Interface on the MPS-CTU top panel is in parallel with terminals 50 to 56. It is used for direct MPS-OPI mounting. See Section 2.3.

I/O module communication is based on the 2-wire multi-drop RS-485 standard. Overall line length must not exceed 1.2 km (4,000'). For line lengths exceeding 10 m (33'), 150-Ω terminations are required at the cable ends. See Fig. 3.9.

3.2.1.10 RS-485 NETWORK COMMUNICATIONS

Terminals 35, 36, and 37 are used for the standard RS-485 interface. See Section 4.2.15.

3.2.2 MPS-OPI CONNECTIONS AND ADDRESS SELECTION

Connect the MPS-OPI to the MPS-CTU using shielded cable (Belden® 3124A or equivalent). The 24-Vdc supply for the MPS-OPI is provided by the MPS-CTU. The cable shield must be connected at both ends so that MPS-OPI transient protection is operational. See Fig. 3.9.

The MPS-OPI has two switches to select its network address. See Figs. 2.2 and 3.8. Up to three MPS-OPI modules can be connected to the I/O MODULE bus, and each active OPI must have a unique address. If one OPI is used, address 1 must be used. If two OPI's are used, addresses 1 and 2 must be used. If three OPI's are used, addresses 1, 2, and 3 must be used.

Table 3.1 and Fig. 3.8 shows the addressing selection format.

TABLE 3.1 MPS-OPI ADDRESS SELECTION

ADDRESS	SWITCH 1	SWITCH 2
0 (Factory Test)	Open	Open
1 (First OPI)	Closed	Open
2 (Second OPI)	Open	Closed
3 (Third OPI)	Closed	Closed

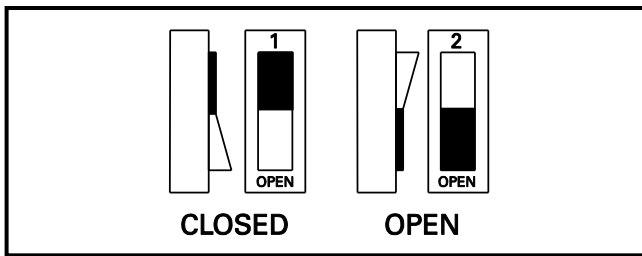

FIGURE 3.8 Address Selection Switch Detail.

3.2.3 MPS-RTD CONNECTIONS AND ADDRESS SELECTION

MPS-RTD terminal blocks accept 24 to 12 AWG (0.2 to 2.5 mm²) conductors.

Connect the MPS-RTD to the MPS-CTU using the four-conductor shielded cable (Belden 3124A or equivalent) as shown in Fig. 3.9. The MPS-CTU 24-Vdc supply can power up to three MPS-RTD modules.

Connect RTD's to the MPS-RTD as shown in Fig 3.9. When the RTD module is installed in a motor junction box, RTD-lead shielding is not required.

Connect the surge-protection (SPG) terminal 20 to terminal 19 (\oplus), and earth terminal 19.

The MPS-RTD has two switches to select its network address. See Figs. 3.8 and 3.10. Up to three MPS-RTD modules can be connected to the I/O MODULE bus, and each RTD-module address must be unique. If one module is used, address 1 must be used. If two RTD modules are used, addresses 1 and 2 must be used. If three RTD modules are used, addresses 1, 2, and 3 must be used.

Table 3.2 shows the addressing selection format.

TABLE 3.2 MPS-RTD ADDRESS SELECTION

ADDRESS	SWITCH 1	SWITCH 2
0 (Offline)	Open	Open
1 (First RTD Module)	Closed	Open
2 (Second RTD Module)	Open	Closed
3 (Third RTD Module)	Closed	Closed

3.2.4 MPS-DIF CONNECTIONS

The MPS-DIF CT-input terminal blocks accept 22 to 10 AWG (0.3 to 4.0 mm²) conductors. The remaining MPS-DIF clamping blocks accept 24 to 12 AWG (0.2 to 2.5 mm²) conductors.

Connect the MPS-DIF to the MPS-CTU using four-conductor shielded cable (Belden 3124A or equivalent) as shown in Fig. 3.9.

Connect the surge-protection (SPG) terminal 15 to terminal 14 (\oplus), and earth terminal 14.

3.2.4.1 CORE BALANCE

The core-balance connection is shown in Fig. 3.11. To minimize power-cable and CT-lead length, both the differential CT's and the MPS-DIF can be located near the motor. The primary rating of the differential CT does not have to match the phase-CT primary rating and is usually selected with a lower ratio resulting in more sensitive differential protection. The core-balance method avoids CT-matching issues and is the preferred connection.

3.2.4.2 MPS SUMMATION

The MPS summation connection uses three phase CT's and three differential CT's as shown in Fig. 3.12. Both CT ratio and CT-saturation characteristics must be matched to avoid differential currents under motor starting and running conditions. The MPS-DIF module should be located near the MPS-CTU to minimize CT wire length. It is preferred to use three dedicated phase CT's and three core-balance differential CT's as described in Section 3.2.4.1.

For the delta connection, the MPS *FLA Rating* is set equal to the motor's full-load current multiplied by $\sqrt{3}$. Power, power factor and energy measurements are not correct for the delta connection.

3.2.4.3 DIF SUMMATION

The DIF summation connection uses six differential CT's as shown in Fig. 3.13. Both CT-ratio and CT-saturation characteristics must be matched to avoid differential currents under motor starting and running conditions. It is preferred to use three core-balance CT's as described in Section 3.2.4.1. This six CT connection allows the CT's and MPS-DIF to be placed near the motor to minimize power-cable and CT-lead length.

3.2.5 DIELECTRIC-STRENGTH TESTING

Dielectric-strength testing should be performed only on CT inputs, PT inputs, output relays, and digital inputs. Unplug all other I/O and remove the SPG connection (terminal 4 to terminal 4A) on the MPS-CTU during dielectric-strength testing.

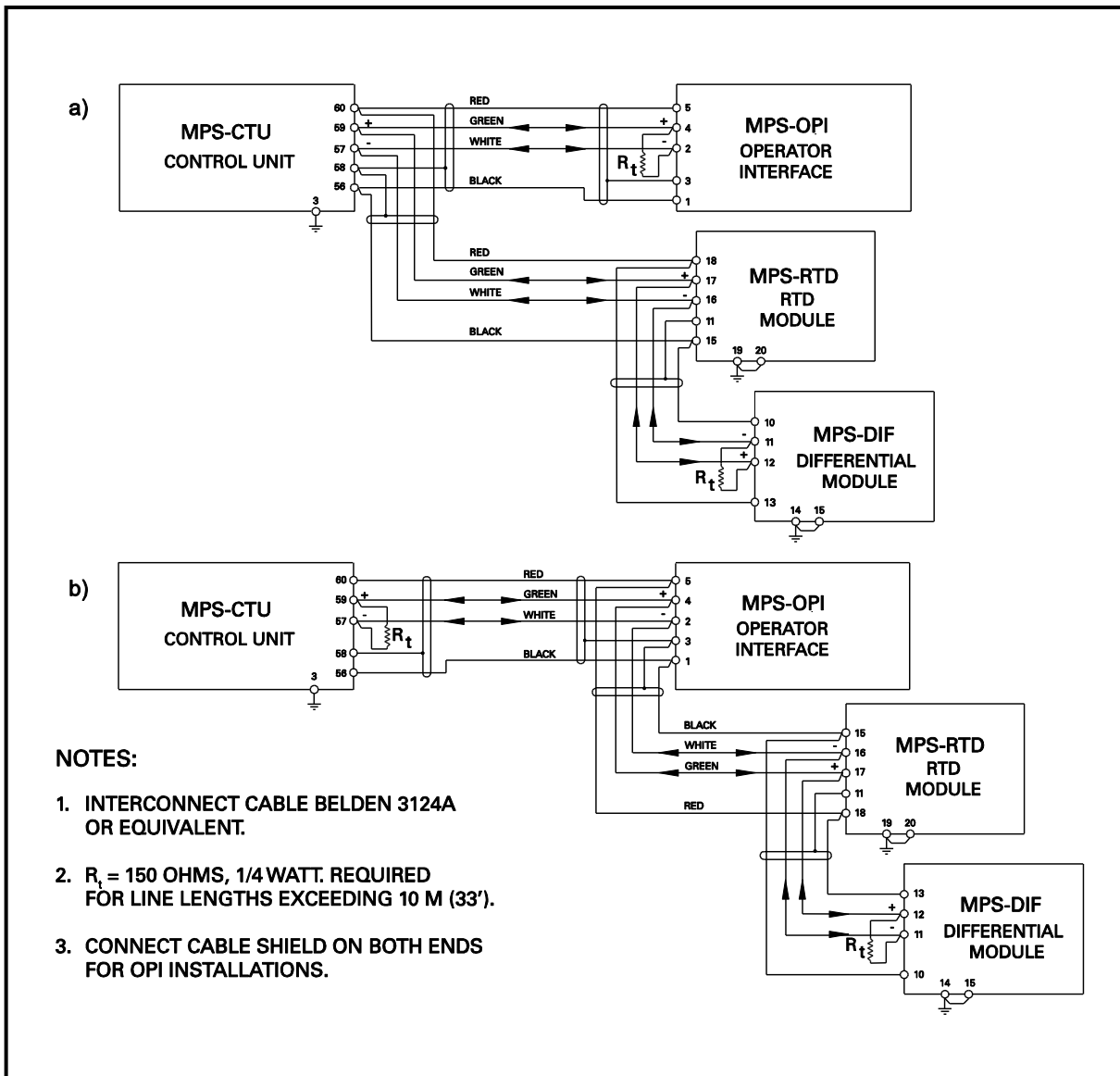

FIGURE 3.9 Two Examples of I/O Module Connections.

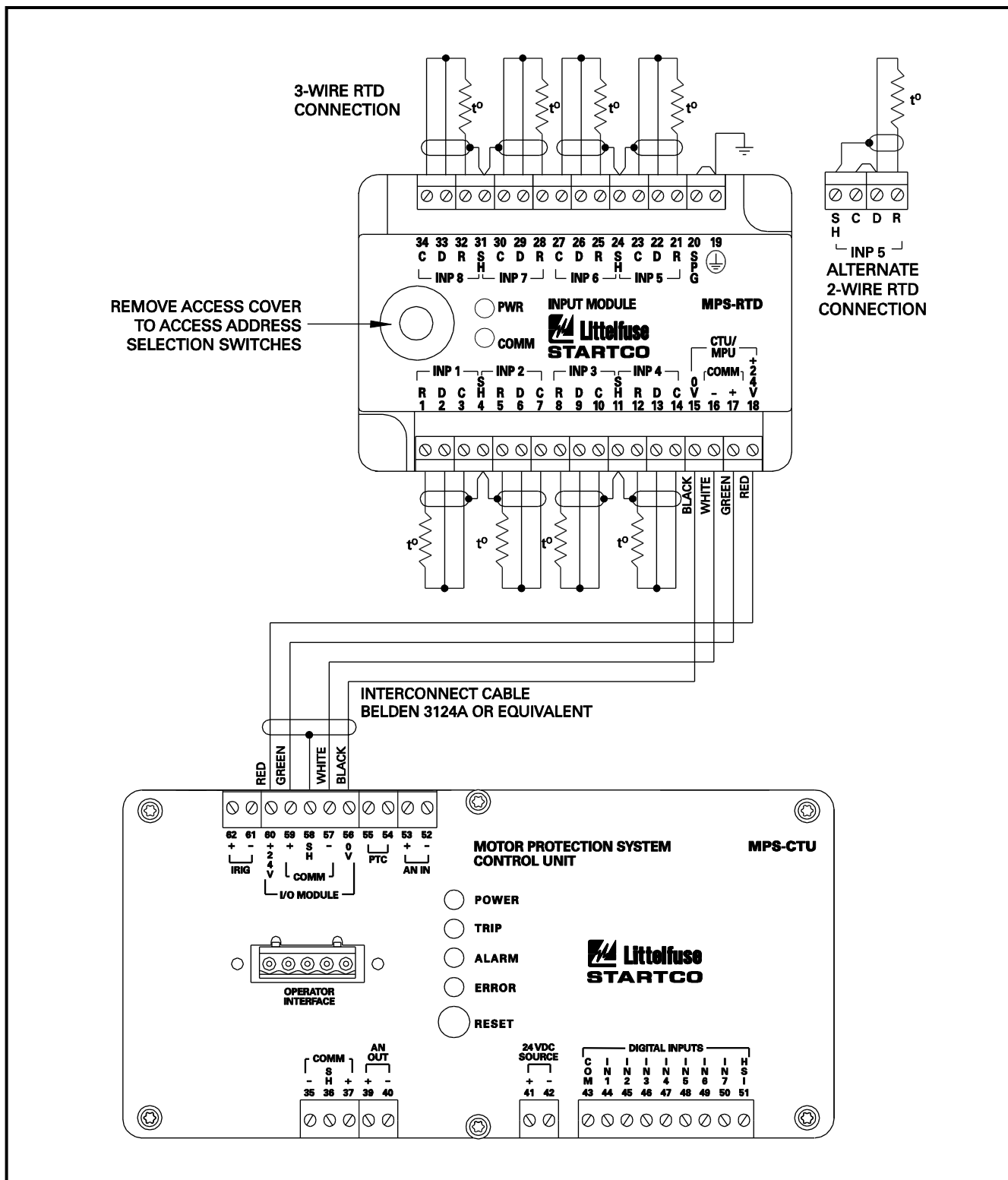

FIGURE 3.10 MPS-RTD Connection Diagram.

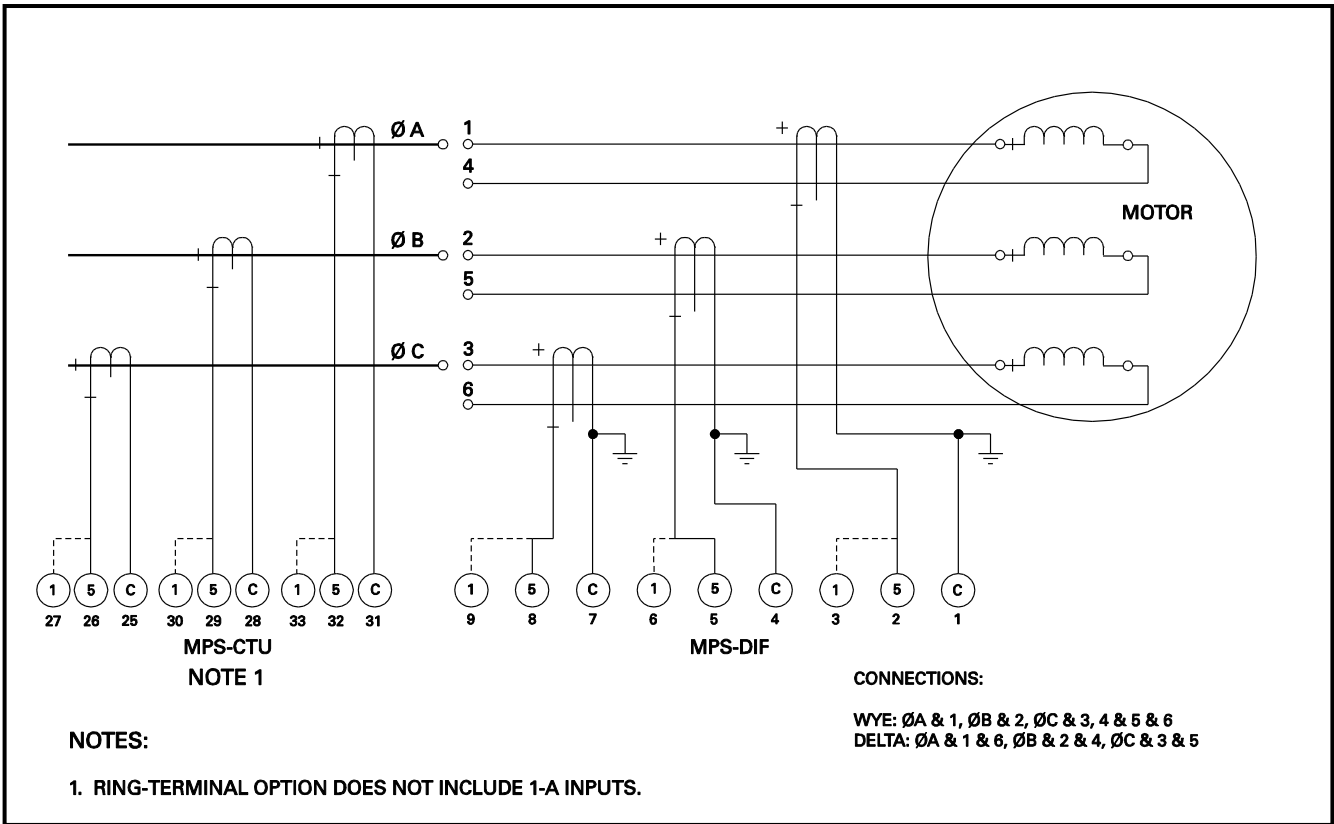

FIGURE 3.11 Core Balance Connection.

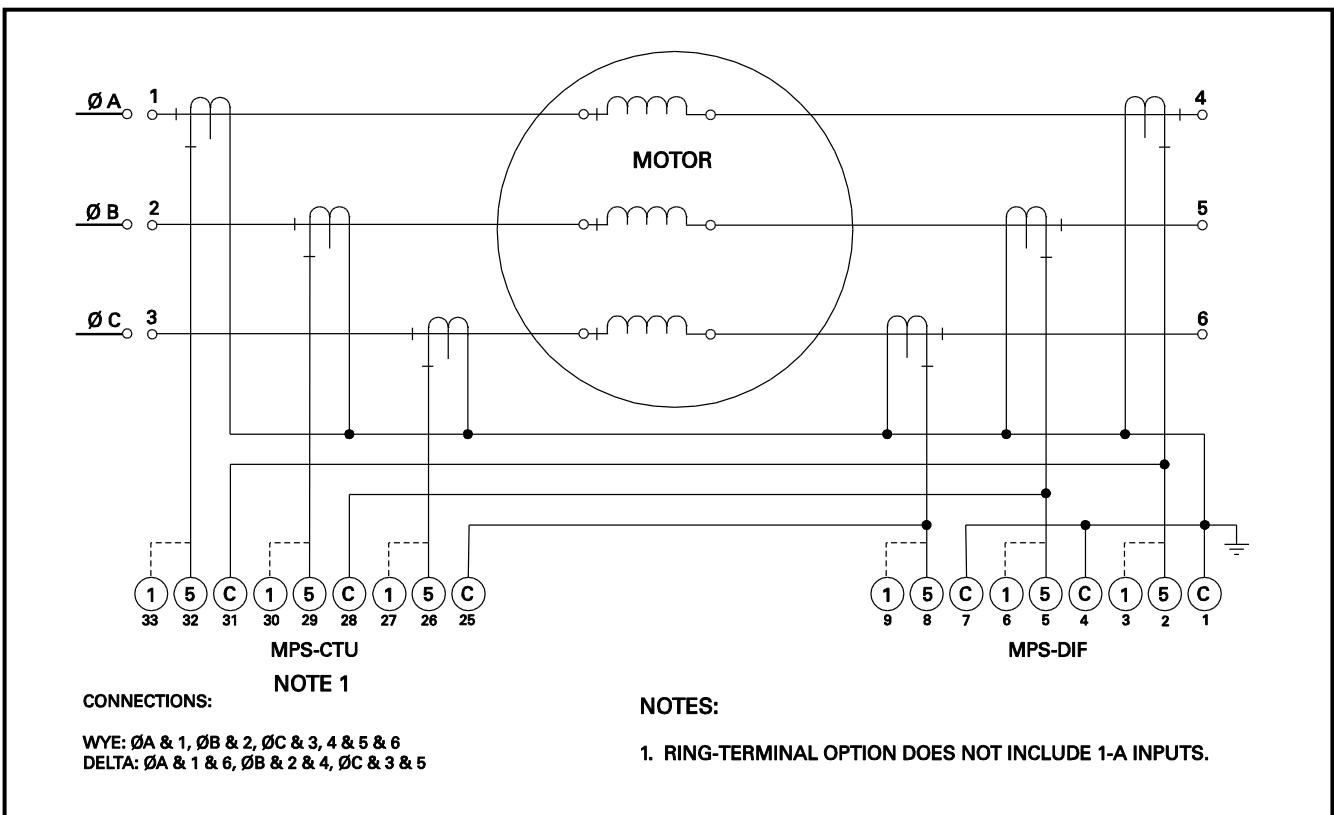

FIGURE 3.12 MPS Summation Connection.

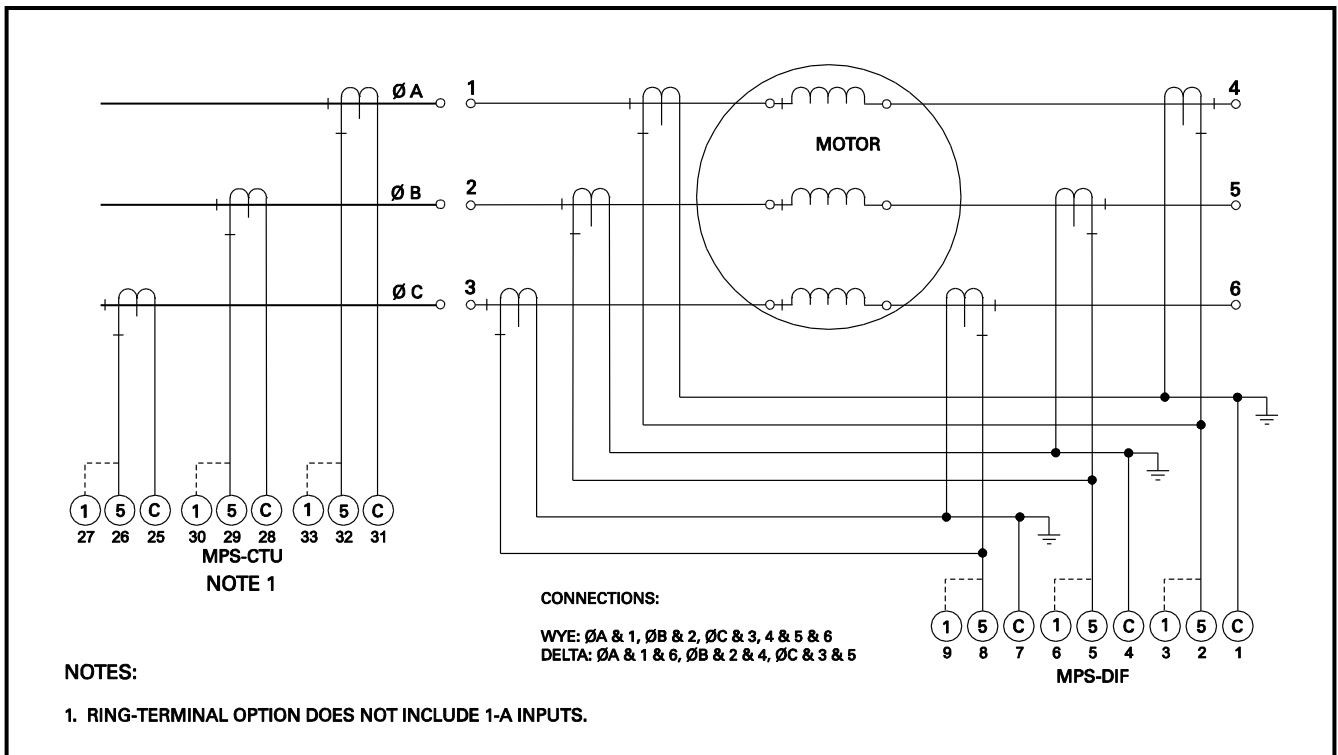

FIGURE 3.13 DIF Summation Connection.

This page intentionally left blank.

4. OPERATION AND SETUP

4.1 GENERAL

The MPS-CTU can operate independently. It can also operate in conjunction with network communications, the MPS-OPI, MPS-RTD and the MPS-DIF. All settings are stored in the MPS-CTU and can be accessed using the OPI or the network communications interface. Use SE-Comm-RIS software and an SE-485PP or SE-485-DIN serial converter to program with a personal computer.

In the following sections, menu items and setup parameters are listed in italics and are shown in the format displayed on the OPI. The OPI cannot display subscripts and superscripts.

Menu selection is in the following format:

Menu 1 | Sub Menu 1 | Sub Menu 2 | Sub Menu 3 |.....

Example: For the menu item shown in Fig. 4.1, the notation is *Setup | System Ratings | CT Primary*

Metering ▶		
Messages ▶		
▲ Setup ▶	Protection ▶	
	◆ System Ratings ▶	
	Starter ▶	▼ CT Primary→
	•	EF-CT-Primary→
	•	System Voltage→
	•	Input Voltage→
	•	
	•	

FIGURE 4.1 Menu Example.

Fig. 4.2 shows the symbols that assist in navigating the menu system and how these symbols relate to the arrow keys on the MPS-OPI. See the menu map in Appendix A.

4.2 MPS-CTU

4.2.1 LED INDICATION

The four LED's on the MPS-CTU indicate POWER (green), TRIP (red), ALARM (yellow), and ERROR (red). The POWER LED is ON when supply voltage is present. The TRIP and ALARM LED's indicate a trip or alarm condition. The ERROR LED is ON during firmware updates or when there is an MPS-CTU failure.

4.2.2 RESET SWITCH

The reset switch is used to simultaneously reset all trips. Trips cannot be held off by a maintained closure.

4.2.3 PHASE-CT INPUTS

OPI Menu: *Setup | System Ratings | CT Primary*

The setting range for the CT-primary rating is 1 to 5,000 A. To maintain specified accuracy, phase CT's should be selected with a primary rating between 100 and 300% of motor full-load current.

Current unbalance will indicate “-” if the current sequence is B-A-C. If B-A-C sequence is indicated, correct the CT connections so that power measurements will be valid.

NOTE: B-A-C sequence will cause a trip if current phase-reverse protection is enabled.

NOTE: Phase-unbalance and phase-loss testing requires three-phase inputs to the MPS.

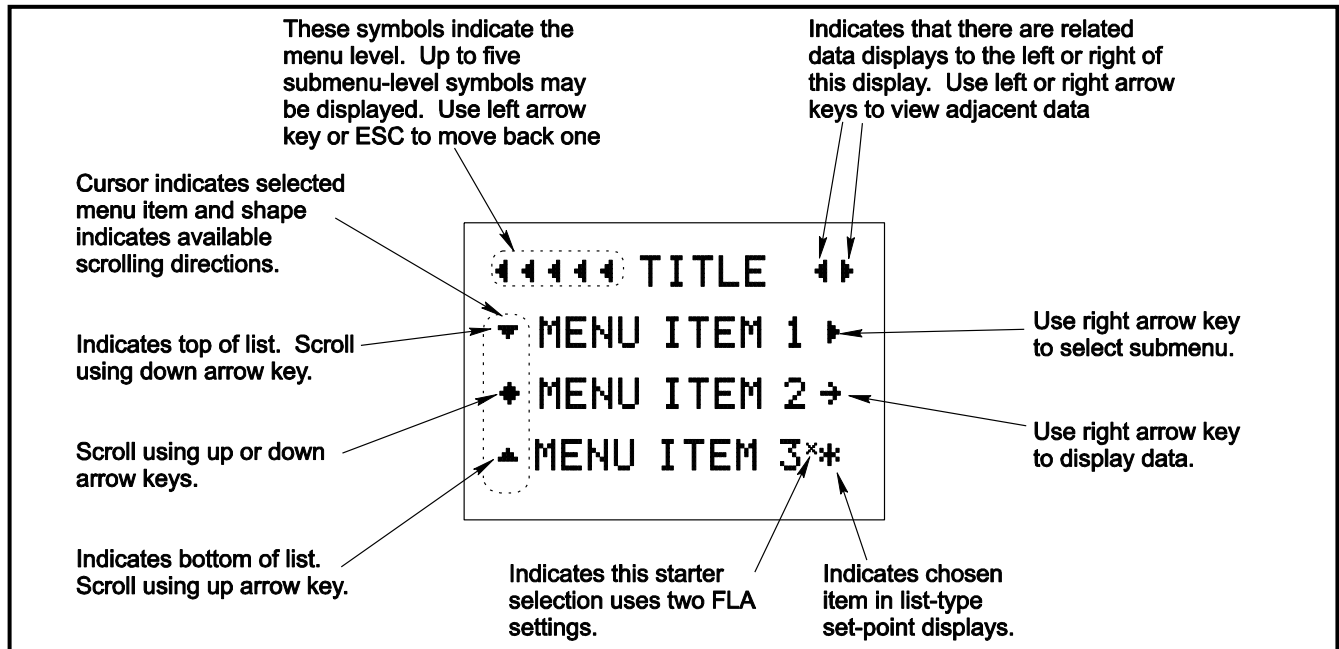

FIGURE 4.2 Menu Symbols.

4.2.4 EARTH-FAULT-CT INPUT

OPI Menu: *Setup | System Ratings | EF-CT Primary*

The setting range for the earth-fault-CT-primary rating is 1 to 5,000 A. The CT-primary rating is 5 A for sensitive CT's—EFCT-1 and EFCT-2.

4.2.5 VOLTAGE INPUTS

OPI Menu: *Setup | System Ratings*

Select the voltage-connection type (1 PT line-line, 2 PT line-line, 3 PT line-neutral/direct) to enable voltage-measuring functions. *System Voltage* is the system line-to-line voltage. The system voltage range is 120 V to 25 kV. For the 1-PT and 2-PT connections, *Input Voltage* is the PT-secondary voltage when system voltage is applied. For the 3-PT connection, the *Input Voltage* is the PT-secondary line-to-line voltage. For the direct connection, set *Input Voltage* the same as the *System Voltage* setting. In all cases, line-to-line voltages are displayed.

Voltage unbalance will indicate “-” if the voltage sequence is B-A-C. If B-A-C sequence is indicated, correct the PT connections so that power measurements will be valid.

NOTE: The 1-PT connection does not allow detection of voltage unbalance.

NOTE: B-A-C sequence will cause a trip if voltage phase-reverse protection is enabled.

4.2.6 MOTOR DATA

OPI Menu: *Setup | System Ratings*

OPI Menu: *Setup | Protection | Overload*

Motor data must be entered for the *FLA Rating*, *Frequency*, and *Service Factor*. If a tachometer is used, the *Sync Speed* is required. If the starter selected requires two FLA ratings, *FLA Rating 2* must be entered.

The *Frequency* setting determines the sampling rate used by the MPS for current and voltage measurements. If *Sync to ASD* is selected as the analog-input type, the *Frequency* setting is not used and the analog output from an adjustable-speed drive determines the sampling rate used by current- and voltage-measuring algorithms. See Section 5.29.2.

Locked-rotor current, cold locked-rotor time, and hot locked-rotor time must be entered in the *Protection | Overload* menu to provide customized overload protection. See Section 5.2.

4.2.7 OUTPUT RELAY ASSIGNMENT

OPI Menu: *Setup | Relay Outputs | Relay x*

Each of the five output relays can be assigned to one of the functions listed in Table 4.1. More than one relay can be assigned the same function. Note that Relay 5 is a solid-state relay with a low current rating and should only be used for interlocks or annunciation.

Relay assignments *Starter RLYA*, *Starter RLYB*, *Starter RLYC*, and *Starter RLYD* operate in conjunction with

MPS starting functions to control the motor-starter contactor(s). See Section 6. Contactor status can be monitored using auxiliary contacts and the digital inputs. See Section 4.2.8 and Figs. 6.9 to 6.23.

TABLE 4.1 OUTPUT-RELAY FUNCTIONS

FUNCTION	ASSIGNMENT OR ACTION
Starter RLYA	Relay is assigned to the Starter Relay A function.
Starter RLYB	Relay is assigned to the Starter Relay B function.
Starter RLYC	Relay is assigned to the Starter Relay C function.
Starter RLYD	Relay is assigned to the Starter Relay D function.
Trip1	Relay operates when a trip occurs in a protective function assigned Trip1, Trip1&2, Trip1&3, or Trip1,2,&3. Fail-safe or non-fail-safe mode selection is active.
Trip1 Pulse ⁽¹⁾	Trip1 energizes the relay for the time duration specified by the <i>RY Pulse Time</i> set point.
Trip2	Relay operates when a trip occurs in a protective function assigned Trip2, Trip1&2, Trip2&3, or Trip1,2,&3. Fail-safe or non-fail-safe mode selection is active.
Trip3	Relay operates when a trip occurs in a protective function assigned Trip3, Trip1&3, Trip2&3, or Trip1,2,&3. Fail-safe or non-fail-safe mode selection is active.
Alarm1	Relay operates when an alarm occurs in a protective function assigned Alarm1, Alarm1&2, Alarm1&3, or Alarm1,2,&3. Fail-safe or non-fail-safe mode selection is active.
Alarm2	Relay operates when an alarm occurs in a protective function assigned Alarm2, Alarm1&2, Alarm2&3, or Alarm1,2,&3. Fail-safe or non-fail-safe mode selection is active.
Alarm3	Relay operates when an alarm occurs in a protective function assigned Alarm3, Alarm1&3, Alarm2&3, or Alarm1,2,&3. Fail-safe or non-fail-safe mode selection is active.
Local	Relay energized when Local starter control is selected.
Interlock	Relay is energized when all digital-input interlocks are completed.
Current	Relay is energized when current is detected.
Run Mode	Relay is energized when motor is running. (Current <125% for <i>Run-Mode Delay</i>)
Sequence Complete	Relay is energized when the starter <i>Start Time</i> has elapsed.
Start Inhibit	Relay is energized when in an I^2t or starts-per-hour inhibit condition.
Watchdog	Relay is energized when the supply voltage is applied and the MPS is operating properly.
Reduced OC	Relay is energized when in maintenance mode (ROC = On).
None ⁽²⁾	No Assignment (Default).

⁽¹⁾ Assign this function to only one relay. Non-fail-safe operation only.

⁽²⁾ Relay outputs must be assigned. Default is None.

When a trip occurs, all assigned starter-control relays (*Starter RLYA* to *Starter RLYD*) are de-energized and relays assigned the *Trip1*, *Trip2*, or *Trip3* function operate. The trip signal may originate from a protective function, from a digital input assigned the *Trip1* function, or from a communications network command. See Sections 4.2.8 and 6.

Relays assigned to trip or alarm functions operate in fail-safe or non-fail-safe mode. Set the mode using the *Setup | Relay Outputs | Relay x | Mode* menu.

Except for overload trips, which can be selected to auto-reset, trips must be reset with an MPS-OPI, a digital input, or a network command. A trip cannot be reset when the trip condition is present.

When a protective function issues an alarm, relays assigned to the corresponding Alarm1, Alarm2, or Alarm3 function operate. Alarms auto-reset when the alarm condition is corrected.

Relays assigned the *Interlock* function energize when all digital inputs assigned the *Interlock* function are valid (voltage detected at digital input).

4.2.8 DIGITAL INPUTS 1 TO 7

OPI Menu: *Setup | Digital Inputs | Digital Input x | Input x Function*

OPI Menu: *Setup | Digital Inputs | Digital Input x | In x Start Bypass*

OPI Menu: *Setup | Digital Inputs | Digital Input x | In x Bypass Delay*

OPI Menu: *Setup | Digital Inputs | Digital Input x | In x Trip Delay*

Each digital input can be assigned to one of the functions listed in Table 4.2. More than one digital input can be assigned the same function.

Start inputs are not active when *Protection Only* is selected as the starter type. The STOP function is always active. In *Protection Only* mode, STOP initiates a *Trip1* signal.

Each digital input assigned the *Trip1* function has *Start Bypass*, *Bypass Delay*, and *Trip Delay* set points. When *Start Bypass* is enabled, the *Trip1* function is bypassed during a start for the duration specified by *Bypass Delay*. Since start detection is based on motor current, this feature can be used in the *Protection Only* mode. After the *Bypass Delay*, the *Trip1* function is enabled and a trip occurs if the digital-input voltage is removed for the time specified by the *Trip Delay*. If *Start Bypass* is disabled, *Bypass Delay* is not used and the *Trip1* function is always enabled. The bypass feature can be used in pump-control applications to allow time for a pressure switch to close.

Reset inputs are “one-shot” resets that require a transition from open to closed. Maintaining a reset switch closure does not inhibit trips.

TABLE 4.2 DIGITAL-INPUT FUNCTIONS

FUNCTION	STATE ⁽¹⁾
Start1	1 = Start1 (Momentary)
Start2	1 = Start2 (Momentary)
Local Select -	1 = Per CONTROL SELECT Setting 0 = Local Control
Local Select +	0 = Local Control ⁽²⁾ 1 = Per CONTROL SELECT Setting
Local Start1 ⁽²⁾	1 = Start1 (Momentary)
Local Start2 ⁽²⁾	1 = Start2 (Momentary)
2-Wire Start1	1 = Start1 (Maintained) 0 = Stop
2-Wire Start2	1 = Start2 (Maintained) 0 = Stop
Stop	1 = Start Allowed 0 = Stop
RLYA Status	1 = Contactor Closed 0 = Contactor Open
RLYB Status	1 = Contactor Closed 0 = Contactor Open
RLYC Status	1 = Contactor Closed 0 = Contactor Open
RLYD Status	1 = Contactor Closed 0 = Contactor Open
Interlock	1 = Start Allowed (If all interlocks are valid.) 0 = Start Not Allowed
Trip1	1 = No Trip1 0 = Trip1 (Delays Selectable)
Reset	1 = Reset Trips
FLA2 Select ⁽³⁾	1 = Select FLA2 0 = Select FLA1
Limit1 Stop	1 = Start1 Allowed 0 = Start1 Stop
Limit2 Stop	1 = Start2 Allowed 0 = Start2 Stop
Reduced OC	1 = Reduced OC Set Point Not Operational 0 = Reduced OC Set Point Operational
None	No Assignment (Default)

⁽¹⁾ 1 = Input voltage applied, 0 = Input voltage not applied.

⁽²⁾ Interlocks bypassed in LOCAL.

⁽³⁾ Applies only to *Protection Only* mode.

LOCAL is selected using the OPI, the digital input, or by network communications. The *Local Select* source is responsible for de-selecting. For example if both the digital input and the network communications select LOCAL, both must also de-select LOCAL. The *Local Select -* and *Local Select +* selections allow the digital input to select LOCAL control. Both positive and negative logic versions allow implementation of various “Hand-Off-Auto” control schemes. See Section 6 for CONTROL SELECT operation.

In applications where MPS starter functions are not used, *FLA2 Select* can be used to switch between FLA1 and FLA2. This applies only to *Protection Only* mode. The selected FLA is displayed in the *Metering | System State* menu.

Limit1 Stop and *Limit2 Stop* are limit-switch inputs typically used with reversing starters. *Limit1 Stop* is a stop input associated with *Start1* and *Limit2 Stop* is a stop input associated with *Start2*.

The *Reduced OC* selection operates in conjunction with the reduced overcurrent set point which must be enabled. See Section 5.5.

When *Reduced OC* is selected and no digital input voltage is applied, the reduced overcurrent set point is operational. When digital input voltage is applied, the reduced overcurrent set point is not operational.

The following rules apply when multiple inputs are assigned the same function:

- *Start1, Start2, Local Start1, and Local Start2*: Momentary voltage on any input will initiate a start. (MPS must be in LOCAL for *Local Start1* and *Local Start2* operation.)
- *Stop*: Voltage must be present on all inputs to allow an MPS-controlled start.
- *Interlock*: Voltage must be present on all inputs to allow an MPS-controlled start and to energize an interlock output relay. Digital inputs programmed as *Interlock* are bypassed in LOCAL. Interlocks must remain valid while the motor is running.
- *RLYA, RLYB, RLYC, and RLYD Status*: Voltage applied to any input programmed for a contactor status results in contactor-closed status.
- *Reset*: Voltage applied to any input will reset trips.
- *2-Wire Start1 and 2-Wire Start2*: Voltage on any input will initiate a start. All inputs must be open for a stop.
- *FLA2 Select*: Voltage on one or more inputs assigned to *FLA2 Select* will select FLA2.

4.2.9 TACHOMETER INPUT (HSI)

OPI Menu: *Setup | System Ratings | Sync Speed*

OPI Menu: *Setup | Digital Inputs | Tachometer*

This input is provided for connection to a 24-Vdc proximity sensor for speed measurement. Set the number of pulses per revolution and enable the High-Speed Input in the *Tachometer* menu. Pulse-frequency range is 10 Hz to 10 kHz. These two settings are required for RPM readings.

If Failure to Accelerate protection is used, set the motor's synchronous speed in the *Sync Speed* menu. To fully utilize a speed-setting range from 10 to 100%, a full-speed frequency of at least 100 Hz is required.

The MPS averages 16 pulse periods to determine speed.

4.2.10 ANALOG OUTPUT

OPI Menu: *Setup | Analog Output | Output Parameter*

A 25-mA programmable current output is provided on the CTU. Analog-output parameters are shown in Table 4.3.

Factory calibration is 4-20 mA. If calibration is required, use the *Analog Output* menus.

Zero Calibration:

- Select *Zero* in the *Output Parameter* menu.
- Measure the output current and adjust the *Zero Calibrate* setting for the desired output. The calibration number for 4 mA will be in the range of 100 to 110.

Full-Scale Calibration:

- Select *Full Scale* in the *Output Parameter* menu.
- Measure the output current and adjust the *FS Calibrate* setting for the desired output. The calibration number for 20 mA will be in the range of 540 to 550.

Calibration numbers are not changed when factory defaults are loaded.

TABLE 4.3 ANALOG-OUTPUT PARAMETERS

PARAMETER	FULL SCALE	COMMENTS
Phase Current	PH-CT-Primary Rating	Maximum of 3 Phases
Earth Leakage	EFCT-Primary Rating	
Differential Current	DF-CT-Primary Rating	Maximum of 3 Currents
Used I ² t Capacity	100% I ² t	
Stator Temperature ⁽¹⁾	200°C (392°F)	Maximum of Stator RTD's
Bearing Temperature ⁽¹⁾	200°C (392°F)	Maximum of Bearing RTD's
Load Temperature ⁽¹⁾	200°C (392°F)	Maximum of Load RTD's
Ambient Temperature ⁽¹⁾	200°C (392°F)	Maximum of Ambient RTD's
Voltage	System Voltage	Maximum Line-to-Line Voltage
Unbalance (I)	1.0 per unit or 100%	I ₂ /I ₁
Power Factor	1.0	Absolute Value
Real Power	CT Primary × System Voltage × √3	Absolute Value
Reactive Power	CT Primary × System Voltage × √3	Absolute Value
Apparent Power	CT Primary × System Voltage × √3	Absolute Value
Zero	Not Applicable	Used for Zero Calibration
Full Scale	Not Applicable	Used for Full-Scale Calibration
Speed	Synchronous Speed	

⁽¹⁾ Output range is 0 to 200°C (32°F to 392°F). The output defaults to the calibrated zero output for an open or shorted RTD sensor.

4.2.11 ANALOG INPUT

OPI Menu: *Setup | 4-20 Analog In | Input Function*

The analog input function is selectable as *Metering Only*, *Protection*, *Sync to ASD*, or *Motor Speed*.

4.2.11.1 METERING ONLY

OPI Menu: *Setup | 4-20 Analog In | Metering Only*

When *Metering Only* is selected, an analog input does not affect MPS operation, but its value can be observed in the Metering menu and with a communications network.

4.2.11.2 PROTECTION

OPI Menu: *Setup | 4-20 Analog In | Protection*

The *Protection* analog input has high- and low-level trip and alarm set points. A high-level trip or alarm occurs when the 4-20-mA input exceeds the high-level trip or alarm set point. A low-level trip or alarm occurs when the 4-20-mA input is lower than the low-level trip or alarm set point.

4.2.11.3 SYNCHRONIZE TO ASD

OPI Menu: *Setup | 4-20 Analog In | Sync to ASD*

When *Sync to ASD* is selected the MPS uses the 4-20 mA input to set the internal sampling rate for current and voltage inputs. Select drive-frequency values corresponding to 4 and 20 mA.

4.2.11.4 MOTOR SPEED

OPI Menu: *Setup | 4-20 Analog In | Motor Speed*

This selection overrides the selections for the high-speed tachometer input – failure-to-accelerate protection and speed metering use the analog input as the source of speed information.

4.2.12 STARTER

OPI Menu: *Setup | Starter*

As a default, *Starter Type* is set to *Protection Only*. When a starter type is selected, output relays must be assigned for contactor control. See Section 4.2.7. Digital inputs must be assigned if contactor-status feedback is required. See Section 4.2.8.

See Section 6 for starter information.

4.2.13 PROTECTION

OPI Menu: *Setup | Protection*

OPI Menu: *Setup | System Ratings | Run Mode Delay*

See Section 5 for protective function details. As a minimum, locked-rotor current and time must be set for overload protection.

Some protective functions are active after the *Run-Mode Delay*.

4.2.14 MISCELLANEOUS CONFIGURATION

OPI Menu: *Setup | System Config*

System Name Appears on many of the display screens and can be set by the user. (18-character alphanumeric field)

Password

Used to change the 4-character alphanumeric password.

Clock Setting

Used to set the date, 24-hour clock, and IRIG set points. Daylight savings time is not supported.

Password Timeout

Used to set the password time-out delay. Delay is measured from last key press.

Maintenance

Used to:

- Clear event records, trip counters, energy values, and run hours
- Load defaults
- View firmware version and serial numbers
- Unlock local control if communication is lost
- Update Firmware

4.2.15 NETWORK COMMUNICATIONS

OPI Menu: *Setup | Hardware | Network Comms*

The standard interface on the MPS is an RS-485 network. Modbus[®] RTU and A-B[®] DF1 protocols are supported.

The protocol, network ID (address), error checking, and baud rate are selectable. See Appendices C, D, E, and F.

If equipped with an optional network interface, refer to the appropriate optional communications-interface manual.

4.3 MPS-OPI

4.3.1 GENERAL

See Fig. 4.3. The Operator Interface (OPI) is used to perform motor-control functions, display meter readings, and program the MPS-CTU. Set points are not resident in the OPI. Control voltage for the MPS-OPI (24 Vdc) is supplied by the CTU and communications with the CTU is through an RS-485 link. This allows the MPS-OPI to be mounted up to 1.2 km (4,000') from the CTU. Up to three OPI's can be used with each CTU.

4.3.2 CONFIGURING THE MPS-CTU FOR OPI OPERATION

OPI Menu: *Setup | Hardware | OPI Display*

Select the number of OPI's in the *Number of OPI's* menu. The MPS-CTU supports up to three OPI's. In multiple-OPI systems, all OPI's display the same information and the CTU will process key presses from all OPI's. If an OPI is not used, set number of OPI's to 1 (default).

A loss-of-communication trip can be enabled in the *OPI-Loss Trip* menu. Display intensity can be set in the *Intensity* menu.

To extend the life of the vacuum-florescent display, a screen saver is provided and enabled using the *Screen Saver* menu. The screen saver activation time is defined by the *Setup | System Config | Password Timeout* setting.

4.3.3 STARTER CONTROL

OPI Menu: *Setup | Starter | Starter Type*
OPI Menu: *Setup | Hardware | OPI Display | OPI Ctrl Select*

A starter type other than *Protection Only* must be selected for starter functions to become operational.

The OPI has a CONTROL SELECT key and three yellow LED's (labeled REMOTE, OPI, and LOCAL) to select and indicate the start sources that the MPS will respond to. Each of the start sources can be enabled or disabled in the *OPI Ctrl Select* menu, and the CONTROL SELECT key allows the operator to choose from among the enabled start sources. The factory default has all sources enabled and REMOTE selected. Regardless of the control setting, all stop sources are always enabled.

4.3.3.1 OPI CONTROL

If only the OPI LED is on, the MPS is under OPI control and start keys on the OPI are the only start source the MPS will respond to. If the OPI has been enabled as a start source for remote control, the OPI LED will also be on when remote control is selected. In this case, the MPS will also respond to the other sources enabled in remote control (*Remote Group*).

4.3.3.2 LOCAL CONTROL

OPI Menu: *Setup | Digital Inputs | Digital Input x | Input x Function*

When the LOCAL LED is on, the MPS is under local control and digital inputs programmed as *Local Start 1* or

Local Start 2 are the only start sources the MPS will respond to.

NOTE: The *I²t Start Inhibit* function and digital inputs programmed as *Interlock* are bypassed in local control.

Local control can also be selected with a network command or by a digital input programmed for *Local Select*—both have priority over the CONTROL SELECT key. If either or both methods force the MPS into local control and then release local control, the MPS will return to the previous control setting. Each local-control source must release local control to allow the MPS to return to the previous control setting.

4.3.3.3 REMOTE CONTROL

OPI Menu: *Setup | Starter | Remote Group*

When the REMOTE LED is on, MPS start control is from the start sources enabled in the *Remote Group* menu. Start source selections are *Digital Inputs*, *OPI*, and *Network*. If *Digital Inputs* is enabled, digital inputs programmed for *Start1*, *Start2*, *2-Wire Start1*, and *2-Wire Start2* are enabled. If *OPI* is enabled, the start keys on the OPI are enabled and if *Network* is enabled, start commands from the network are enabled.

NOTE: The OPI STOP key and digital STOP inputs always cause a stop.

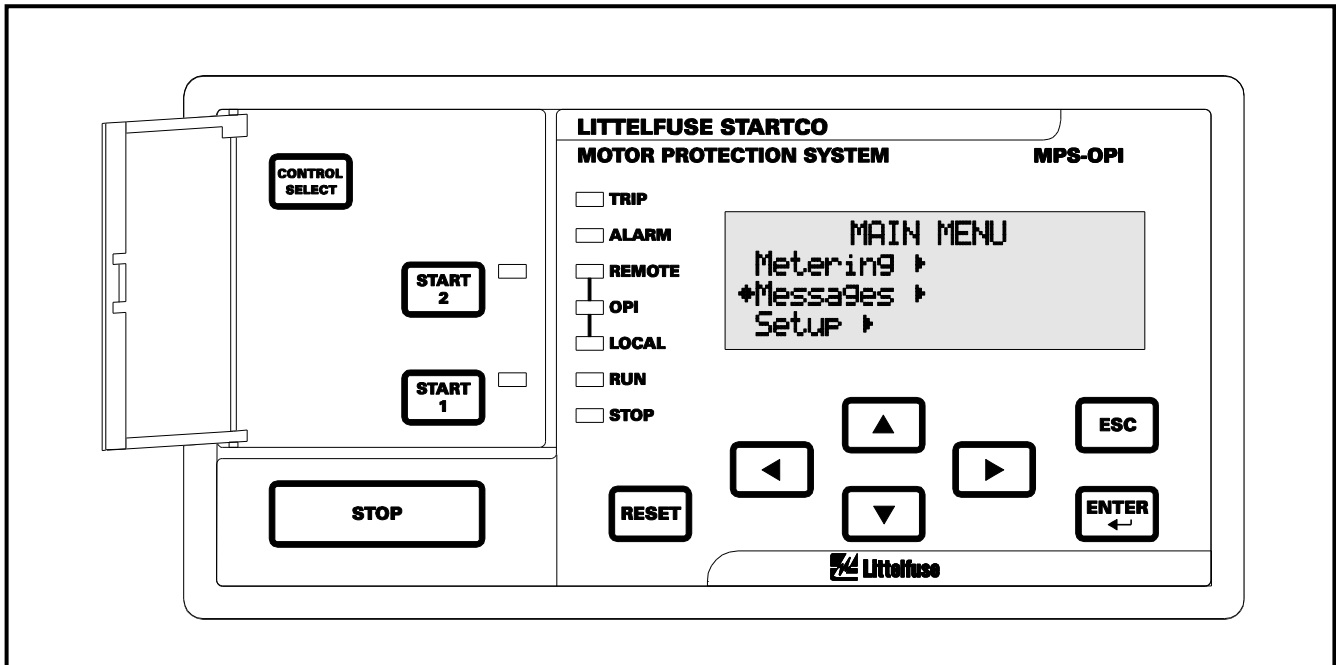

FIGURE 4.3 MPS-OPI Interface.

4.3.4 METERING

OPI Menu: *Metering*

OPI Menu: *Setup | Hardware | OPI Display | Meter Summary*

When *Metering* is selected in the main menu, press the right-arrow key to access a list of metering displays. Use the up- and down-arrow keys to scroll through the display list. Pressing the right-arrow key displays the selected metering information. See the MPS-OPI menu map in Appendix A.

RESET is a “hot key” that is active in all meter displays. Pressing RESET causes a jump to the *Trip and Alarm* display to allow trips to be viewed and reset. Press RESET again to reset a trip. Pressing ESC or the left-arrow key causes a return to the *Metering* display.

Many displays include per unit (pu) values where 1.0 pu is equal to 100%. I_a , I_b , I_c , I_1 , and I_2 are in per unit of full-load current. I_g is in per unit of earth-fault-CT-primary rating. V_{ab} , V_{bc} , and V_{ca} are in per unit of System Voltage.

The unbalance display indicates minus (-) if current inputs are not sequenced A-B-C.

The IEEE convention is used for power displays:

+Watts, +Vars, -PF (Lag)	Importing Watts, Importing Vars
+Watts, -Vars, +PF (Lead)	Importing Watts, Exporting Vars
-Watts, -Vars, -PF (Lag)	Exporting Watts, Exporting Vars
-Watts, +Vars, +PF (Lead)	Exporting Watts, Importing Vars

The operating range for energy values is $\pm 2E \pm 1024$, however the maximum OPI display range is $\pm 2E \pm 34$.

The *Setup | Hardware | OPI Display | Meter Summary* menu is used to configure the type of metering display selected by the *Metering | Summary* menu. In order to view the maximum amount of data, no menu title is displayed.

Display selections for the *Summary* menu are:

- *IDR* Current-based metering (*I*), digital inputs (*D*), and relay outputs (*R*):

Average current, current unbalance, earth leakage, used I^2t , digital input and relay output status.

I: xxxx A Iu: x.xx
Ig:xxxx A I2t:xx%
Di: 1..7: xxxxxxx
Ry: 1..5: xxxxx

This selection is the default for the summary display.

- *IVP* Current-based metering (*I*), voltage (*V*), unbalance, and power (*P*):

Average current, current unbalance, earth leakage, used I^2t , average voltage, voltage unbalance, power and power factor.

I: xxxx A Iu: x.xx
Ig:xxxx A I2t: xx%
V: xx.xx kV Vu: x.xx
P: xx.x kW PF: x.xx

This selection is applicable for an MPS using voltage inputs.

- *IVPA* Current-based metering (*I*), voltage (*V*), power (*P*), and analog I/O (*A*):

Average current, average voltage, earth leakage, used I^2t , power, power factor, and analog currents.

I: xxxx A V: xx.xx kV
Ig:xxxx A I2t:xx%
P: xx.x kW PF: x.xx
Ai:xxx% Ao: xxx%

This selection is applicable when the MPS analog output is used in a process control loop. The analog input and output values provide indication of control-system operation.

For each metering display, Table 4.4 shows the information that can be displayed.

4.3.5 MESSAGES

OPI Menu: *Messages*

Selecting this menu item allows trip and alarm messages, status messages, event records, and statistical data to be viewed and resets to be performed.

4.3.5.1 TRIP RESET

OPI Menu: *Messages | Trip and Alarm*

Up to fifteen trip and alarm messages can be displayed in a scrollable-list format. Trip messages must be individually selected and reset when the OPI RESET key is used. All trips are simultaneously reset by digital-input reset, with the MPS-CTU RESET key or with a communications-network command. Alarms are non-latching and are displayed only for the time that the alarm condition exists.

RESET is a “hot key” to the *Trip and Alarm* display, except during set-point entry. In the *Trip and Alarm* display, press ESC or the left-arrow key to return to the display shown when RESET was pressed.

4.3.5.2 STATUS

OPI Menu: *Messages | Status Messages*

This menu is used to display status messages. Status messages are shown in Table 4.5.

TABLE 4.4 METERING DISPLAY

METERING MENU	INFORMATION DISPLAY ⁽¹⁾
Summary	Displays values as per the <i>Meter Summary</i> menu. IDR, IVP, or IVPA.
Current	I_a, I_b, I_c in A and per unit of I_p .
Unbalance (I)	I_1, I_2 , in per unit of I_p , I_2/I_1 in per unit.
Earth Leakage	I_g in A and per unit of I_e .
Thermal Capacity	Used I^2t in percent. Trend I^2t in percent. Displays reset time when tripped on I^2t . Displays time to trip if in overload. Displays time to I^2t Inhibit removal. Displays time to Starts-Per-Hour Inhibit removal. Displays number of available starts.
Voltage	V_{ab}, V_{bc}, V_{ca} in kV and per unit of V_p .
Unbalance (V)	V_1, V_2 , in per unit of V_p , V_2/V_1 in per unit.
Unbalance (I)	I_1, I_2 , in per unit of FLA, I_2/I_1 in per unit.
Differential (A)	DIF _a , DIF _b , DIF _c in A and per unit of I_d .
Power	P in kW, Q in kVA, S in kVAR, PF.
Energy	kWh, kVAh, kVARh.
Frequency	V_{ab} voltage in per unit of V_p and frequency in Hz.
RTD Temperatures	Summary shows maximum and minimum temperatures for stator, bearing, and load RTD's in degrees C. Module and input numbers, name, function, temperature in degrees C for each enabled RTD.
I/O Status	Analog input in mA, digital inputs and relay outputs in binary.
System State	Date and Time, Motor Mode (Stopped, Start, Run) Displays starter state when starter is enabled. Displays active FLA when in protection-only mode. Displays RPM if tachometer input is enabled. Displays Reduced Overcurrent mode (ROC: ON, ROC: OFF) Displays ETR mode.
Comm State	Displays DF1 state as online or timed out. Displays Modbus state as online or timed out. Displays Anybus module error and status. Displays DeviceNet errors and status.

⁽¹⁾ All but Summary, RTD, and System State metering displays show System Name.

TABLE 4.5 STATUS MESSAGES

MESSAGES	DESCRIPTION
INx Interlock Open	The interlock assigned to digital input x is open, preventing a start.
INx Stop Open	The stop switch assigned to digital input x is open, preventing a start.
INx Limit1 Open	The Limit1 switch assigned to digital input x is open, preventing a <i>Start1</i> .
INx Limit2 Open	The Limit2 switch assigned to digital input x is open, preventing a <i>Start2</i> .
I^2t Start Inhibit	The <i>Used I^2t</i> has exceeded the <i>I^2t Inhibit level</i> . A start is prevented if <i>I^2t Start Inhibit</i> is enabled.
Sph Start Inhibit	The number of starts per hour has been exceeded. A start is prevented if a starts-per hour trip or alarm is enabled.
t° Disabled by ETR	Indicates that the MPS is in ETR mode. Does not prevent a start.
Backspin Timer On	When a stop is issued and the backspin timer is enabled, a start is prevented until the backspin timer times out. This message is displayed when the backspin timer is on.

4.3.5.3 DATA LOGGING

OPI Menu: *Messages | Event Records*

Trip-record data, start-record data, and Emergency Thermal Resets (ETR) are logged. Trip-record data includes the time of trip, cause of trip, and pre-trip ⁽¹⁾ data. ETR records contain a snapshot of the data prior to an ETR.

Trip or ETR records include:

- Time Stamp YY/MM/DD HH:MM:SS
- V_{ab} , V_{bc} , V_{ca} , I_a , I_b , I_c , and $3I_0$ at time of trip or ETR
- Unbalance (I_2/I_1 , V_2/V_1) at time of trip or ETR
- P, Q, S, and PF at time of trip or ETR ⁽¹⁾
- Used I^2t at time of trip or ETR
- PTC/RTD temperature data if applicable
- Differential module data if applicable

Start records⁽²⁾ are triggered by motor current and include:

- Time Stamp YY/MM/DD HH:MM:SS
- Maximum values of I_a , I_b , I_c , and $3I_0$ during the start
- Maximum value of I_2/I_1 ⁽⁴⁾, V_2/V_1 during the start
- Minimum values of V_{ab} , V_{bc} , V_{ca} during the start
- Maximum differential currents during the start if applicable
- I^2t used during the start⁽³⁾
- Start duration
- PTC/RTD temperature data if applicable

Record TypeTrip/Start/ETR
Number of Records64 (First In First Out)

- (1) Recorded values for power quantities (P, Q, S, PF) are averages of measurements over the previous 16 cycles.
- (2) Values updated at 0.5-s intervals during a start. Record logged when the Run mode is entered.
- (3) Starting I^2t can be used to determine the I^2t Lockout Level. See Section 5.2.
- (4) Measurements enabled 0.5 s after start current is detected.

4.3.5.4 STATISTICAL DATA

OPI Menu: *Messages | Statistics*

OPI Menu: *Setup | System Config | Maintenance*

The MPS records the following statistical data:

- Running hours.
- Counters for all trips.

Statistical data can be cleared in the *Maintenance* menu.

4.3.5.5 EMERGENCY THERMAL RESET

OPI Menu: *Messages | Emerg I2t Reset*

The *Emerg I2t Reset* menu is used to reset the thermal memory. See Section 5.2.3.

4.3.6 PASSWORD ENTRY AND PROGRAMMING

OPI Menu: *Setup | System Config | Password Timeout*

NOTE: Factory default password is 1111.

All set points are locked from changes until the four-character password is entered. If set-point access is locked, the user is prompted to enter the password. Once entered, set-point access is allowed and remains enabled until a key has not been pressed for the time defined by the *Password Timeout* set point.

EXAMPLE:

Prior to password entry:

```
LR CURRENT
= 6.75 x FLA
Locked! Press ↵ To
Enter Password.
```

When ENTER is pressed, the *Password Entry* display is shown:

```
PASSWORD ENTRY
Enter Password
And Press ↵
[****]
```

Use the left- and right-arrow keys to select the position of the flashing cursor. Use the up- and down-arrow keys to select password characters. Press ENTER.

When the correct password is entered, a flashing cursor is displayed, the set-point range and units are shown, and set points can be changed.

```
LR CURRENT
= 6.75 x FLA
(1.00 ÷ 10.00 x FLA)
[00005.25]
```

Use the up- and down-arrow keys to change a set-point update-field character, and use the left- and right-arrow keys to move between characters. Press ENTER to update the set point, or press ESC to exit the display without changing the set point. A set point is set to the minimum or maximum value of its range if an out-of-range value is entered. Press ESC to exit the set-point-update screen.

The sequence for set-point characters depends upon the set-point type. The character sequence for numeric set points is:

...0 1 2 3 4 5 6 7 8 9 . 0 1 2 3

The character sequence for string set points is:

... [0...9] [A...Z] [a...z] SP - ./ [0...9] [A...Z]

Characters forming a series are shown in brackets and "SP" represents the space character.

For set points requiring selection from a list, the up and down arrow keys are used to scroll through the items. In the same manner as menu items, selections are displayed using one of the three cursor symbols (↑, ←, ↓) preceding the item. Pressing ENTER selects the item and that item is indicated by the "*" symbol to its right.

EXAMPLE:

```

STARTER TYPE
Full U Non Reverse
* Adj. Speed Drive *
Soft Start
    
```

4.4 MPS-RTD

OPI Menu: *Setup | Hardware | RTD Modules*

OPI Menu: *Setup | Protection | RTD Temperature*

The MPS-RTD module extends MPS protective functions to include multiple-RTD temperature monitoring. It has eight inputs that can be individually configured for RTD type, trip and alarm settings, name, and function. The RTD types are 10-Ω copper, 100-Ω nickel, 120-Ω nickel, and 100-Ω platinum. Functions are stator, bearing, load, and ambient.

Control voltage for the MPS-RTD (24 Vdc) is supplied by the MPS-CTU and communication is through an RS-485 link. This allows the MPS-RTD to be mounted up to 1.2 km (4,000') from the MPS-CTU.

To enable RTD protection, the total number of modules must be selected in the *Total Modules* menu and Temperature Trip Action or Alarm Action must be enabled. If RTD protection is disabled, metering information is still provided. Up to three modules can be used. In the *RTD Modules* menu, the action to be taken by the MPS-CTU in response to loss of communication is selected.

When the hardware has been configured, temperature set points and sensor-failure action selections in the *RTD Temperature* menu are used for RTD temperature protection. See Section 5.27.

4.5 MPS-DIF

OPI Menu: *Setup | Hardware | DIF Module*

OPI Menu: *Setup | Protection | Differential*

The MPS-DIF Differential Module extends MPS protective functions to include phase-differential monitoring. It has three differential-CT inputs that can be used in a three-CT core-balance connection, a six-differential-CT connection, or a six-CT connection that includes phase-CT MPS inputs. The core-balance, three-CT connection is recommended.

Control voltage for the MPS-DIF (24 Vdc) is supplied by the MPS-CTU and communication is through an RS-485 link. This allows the MPS-DIF to be mounted up to 1.2 km (4,000') from the MPS-CTU, and the link can be shared by other MPS I/O modules.

Enable the module and loss-of-communications protection in the *Hardware | Dif Module* menu, and choose protection settings in the *Protection | Differential* menu. See Section 5.25.

4.6 WAVEFORM CAPTURE

The MPS continuously samples seven channels of data consisting of the three-phase currents, three-phase voltages, and the earth leakage current. The sample rate is fixed at 16 samples/cycle and sample data (Trace Data) for each channel are stored in a 4800 sample memory. This provides a record depth of 300 cycles, or 5 seconds of pre-trip data at 60 Hz.

When a trip occurs, Trace Data capture is halted and a date and time stamp is added. Trace Data values are retrieved using SE-Comm-RIS which generates an industry-standard COMTRADE and CSV file. See Appendix E for data mapping definitions and conversion formulas.

The *Setup | System Config | Trace Auto-Start* menu is used to set the Trace Data start mode after a trip has occurred. When enabled, Trace Data capture automatically starts when reset is pressed. When disabled, Trace Data capture requires a manual re-start using the *Messages | Re-Start Trace*. This allows the MPS to be reset and the trip data to be analyzed at a later time. Trace Data start can also be activated using Command 13 via the communications interface.

Trace Data are stored in volatile memory and are lost if the MPS loses supply voltage. Regardless of the *Trace Auto-Start* setting, waveform capture starts automatically on power-up if there are no previous trips.

5. PROTECTIVE FUNCTIONS

5.1 GENERAL

The MPS measures true RMS, peak, and fundamental-frequency values of current and voltage. Fundamental-frequency values (magnitude and phase angle) are obtained using Discrete-Fourier Transform (DFT) filtering that rejects dc and harmonics. The type of measurement used for a protective function is indicated in each section.

Unless otherwise indicated, protective functions have a programmable definite-time characteristic. Each protective function can be assigned a trip action that defines the output contact(s) used. Except for overload protection, which has auto-reset available, MPS trips are latched. Trips are logged.

Trip-action selections are:

- Disable
- Trip1 ⁽¹⁾
- Trip2 ⁽²⁾
- Trip3 ⁽²⁾
- Trip1 and Trip2
- Trip1 and Trip3
- Trip1 and Trip2 and Trip3
- Trip2 and Trip3

⁽¹⁾ Initiates a starter stop. See Section 6.

⁽²⁾ Does not initiate a starter stop. See Section 6.

Most protection functions can be assigned an alarm action. Alarms auto-reset and are not logged.

Alarm-action selections are:

- Disable
- Alarm1
- Alarm2
- Alarm3
- Alarm1 and Alarm2
- Alarm1 and Alarm3
- Alarm1 and Alarm2 and Alarm3
- Alarm2 and Alarm3

To operate output contacts, trip and alarm actions must be assigned to output relays using the *Setup | Relay Outputs* menu. See Section 4.2.7.

NOTE: When starter functions are used, only set points with a Trip Action that includes Trip1 will cause the starter to stop when a trip occurs.

When enabled, Jam, Power-Factor, Undercurrent, and Underpower protection are not active during a start and are active in the Run mode. The Run mode is initiated when motor current is between 1.5 x (CT-Primary Rating/FLA) and 125% FLA for the duration of the setting in the *Setup | System Ratings | Run Mode Delay* menu.

Run Mode Delay is adjustable from five to 120 seconds. Run-mode status is displayed in the *Metering | System State* menu. One of three states are indicated: Motor:Start, Motor:Run, or Motor:Off. The motor status line also indicates one of two states for the Reduced Overcurrent (ROC) feature: ROC:OFF or ROC:ON. See Section 5.5.

NOTE: See Appendix B for default set-point values. Per-unit notation (pu) is used. 1 pu = 100%.

5.2 OVERLOAD

At a minimum, for customized thermal-overload protection, motor data, must be entered for Full-Load Current, Service Factor, Locked-Rotor Current, Cold Locked-Rotor Time, and Hot Locked-Rotor Time.

5.2.1 THERMAL MODEL

OPI Menu: *Setup | Protection | Overload*

OPI Menu: *Setup | System Ratings*

A NEMA- or K-factor-based thermal-model algorithm can be selected.

The NEMA-based algorithm uses the square of the maximum RMS phase current as the thermal-model input:

$$I^2 = I_{max\ rms}^2 \quad I \text{ in per unit of FLA}$$

The K-factor-based algorithm uses a thermal-model input based on true positive- and negative-sequence component values:

$$I^2 = I_1^2 + kI_2^2 \quad I \text{ in per unit of FLA}$$

Where:

I_1 = positive sequence current

I_2 = negative sequence current

k = factor relating the heat produced by I_2 relative to I_1

A conservative value for k is:

$$k = \frac{230}{I_L^2}$$

Where:

$$I_L = \frac{\text{locked rotor current}}{\text{full load current}}$$

The thermal time constant (τ) used by the thermal model to provide starting and running I^2t protection is:

$$\tau = \frac{T_C}{-\ln\left(1 - \frac{sf^2}{I_L^2}\right)}$$

Where :

T_C = cold locked rotor time in seconds

sf = service factor in per unit

When the motor is stopped, the thermal model uses a time constant that is user selectable as a multiple (*Cooling Factor*) of the thermal time constant (τ).

The cold-curve time-to-trip (t) for current above $FLA \times sf$ is:

$$t = -\ln\left(1 - \frac{sf^2}{I^2}\right) \times \tau$$

The MPS provides indication of thermal trend and used thermal capacity. Thermal trend is the value that used thermal capacity is tending toward and it is a function of the square of motor current. For currents greater than or equal to $FLA \times sf$, time-to-trip is displayed in *Metering | Thermal Capacity*. The thermal trend value (Trend I^2t) is:

$$Trend I^2t = \left(\frac{I^2}{sf^2}\right) \times 100\%$$

For currents less than $FLA \times sf$, the thermal trend value is:

$$Trend I^2t = \left(\frac{I^2}{sf^2}\right) \times \left(\frac{T_C - T_H}{T_C}\right) \times 100\%$$

Where:

T_H = hot locked rotor time in seconds

The curve shown in Fig. 5.1 is a Class-20 thermal-protection curve (20-s trip @ 600% FLA) with a service factor of 1.15. FLA multiplied by service factor is the current at which used thermal capacity begins to trend towards a trip. Time-to-trip approaches infinity when $I = FLA \times sf$. Service factor has little influence on time-to-trip when motor current is greater than 300% FLA.

MPS thermal-overload protection is dynamic. Time to trip at any overload current depends on the value of *Used I^2t* — as *Used I^2t* increases, time to trip decreases. This is illustrated in Fig. 5.1 by the protection curves labelled 25% *Used I^2t* , 50% *Used I^2t* , and 75% *Used I^2t* . Programming software SE-Comm-RIS has a plot function to display and export MPS protection curves.

An overload alarm occurs when *Used I^2t* reaches the *I^2t Alarm Level* set point.

An overload trip occurs when *Used I^2t* reaches 100%. When an overload trip occurs, reset is not allowed until *Used I^2t* falls below the *I^2t Inhibit Level* set point. The time-to-reset in minutes is:

$$t = -\tau \times \text{Cooling Factor} \times \ln(I^2t \text{ Inhibit Level}) / 60$$

Time-to-reset is displayed in the *Metering | Thermal Capacity* menu. The thermal model has three reset modes; *Normal*, *Auto*, and *Multiple Motor Seq.* The thermal-overload reset mode is set using the *Setup | Protection | Overload | I^2t Reset Type* menu.

In the *Normal* mode, a thermal-overload trip reset is not allowed until *Used I^2t* falls below the *I^2t Inhibit Level* setting. A reset input is required to reset the trip. *Normal* is the default reset mode.

In the *Auto* mode, a thermal-overload trip is automatically reset when *Used I^2t* falls below the *I^2t Inhibit Level* setting.

NOTE: If the starter circuit is configured for 2-wire control, the motor can start without warning when *Auto* mode is selected. A warning label may be required.

In the *Multiple Motor Seq.* mode, *Used I^2t* decreases exponentially with a fixed two-second time constant when there is no motor current. This mode is used in applications where one overload relay is used to protect several motors operating in sequence with only one motor running at any one time. A two-second stop is required between starts so that *Used I^2t* decreases sufficiently to allow the next motor to start. It is assumed that each motor is allowed to cool between starts. Motor life may be decreased if this feature is used in single-motor applications. When an overload trip occurs, the trip is latched but can be reset two seconds after the trip.

When *I^2t Start Inhibit* is enabled, the *I^2t Inhibit Level* set point can be used to prevent a start with insufficient I^2t available. When *Used I^2t* is above the *I^2t Inhibit Level* set point and motor current is not detected, Alarm1 is issued, starter functions Start1 and Start2 are disabled, and the relay assigned to *Start Inhibit* is energized. The time until a start is permitted is displayed in *Metering | Thermal Capacity*, and *I^2t Inhibit Alarm* is displayed in the *Trip and Alarm* message window. When *Used I^2t* falls below the *I^2t Inhibit Level* set point, the relay assigned to *Start Inhibit* is de-energized, the inhibit alarm is cancelled, and starter functions Start1 and Start2 are enabled. Trips require a manual reset. *I^2t Start Inhibit* is removed when current is detected. This applies in both Starter and Protection-only modes. The Start-Inhibit relay is shared with the Starts-Per-Hour function. See Section 5.23.

If the motor is equipped with RTD sensors, the thermal model can compensate for high ambient temperature and loss of ventilation. See Section 5.27.

I^2t used during each start is recorded in *Messages | Event Records*. This information can be used to determine the *I^2t Inhibit Level* set point to ensure sufficient I^2t is available to complete a start, and to minimize thermal-overload-reset time.

FLA Rating	1.00 to 5,000.00 A	
Service Factor	1.00 to 1.25	
Locked-Rotor Current.....	1.50 to 10.00 x FLA	
Hot Locked-Rotor Time	0.10 to 100.00 s	
Cold Locked-Rotor Time.....	0.10 to 100.00 s	
Cooling Factor	0.10 to 10.00	
Model Type:	NEMA, K-Factor	
I^2t Reset Type.....	Normal, Auto, Multiple Motor Sequence	
K-Factor	1.00 to 10.00	
I^2t Alarm	0.50 to 1.00 pu	
	I^2t Inhibit Level	0.10 to 0.90 pu

I²t Start InhibitEnable/Disable
 ProtectionEnable/Disable Trip1, 2, 3
 Enable/Disable Alarm1, 2, 3

Measurement MethodDFT or RMS

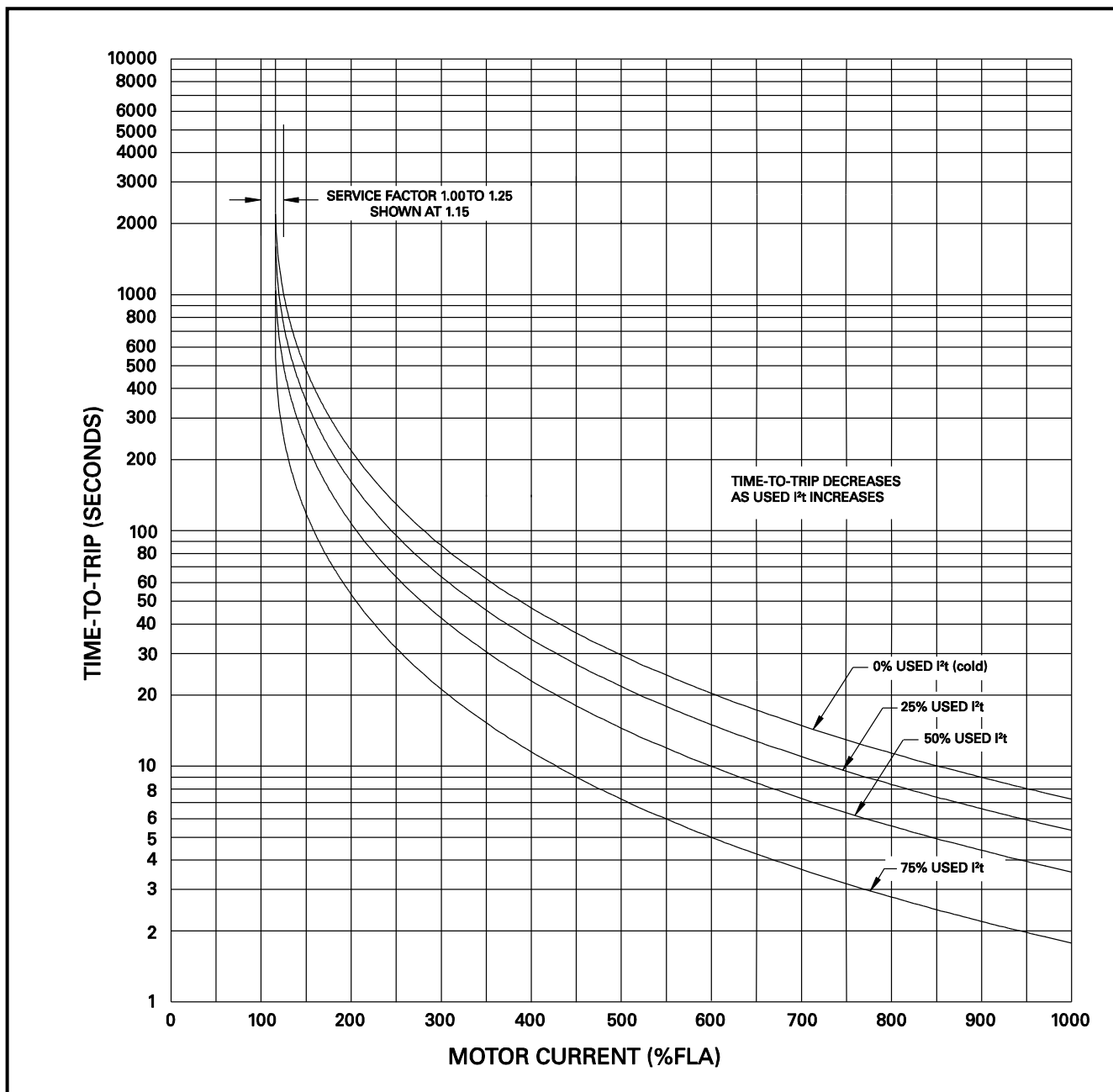

FIGURE 5.1 Class-20 Overload Curve.

5.2.2 LOCKED-ROTOR TIMES

In all cases, values for T_H and T_C should be obtained from the motor manufacturer. The following information is provided to assist in selecting values for T_H and T_C only if manufacturer data is not available.

Heater-style overload elements are available as Class 10, Class 20, or Class 30. Class 20 is recommended for general applications, Class 10 is used for motors with short locked-rotor time capability, and Class 30 is used in high-inertia applications to allow additional accelerating time where motors are within Class-30 performance requirements. These overloads can be replicated by setting $T_C = 10, 20, \text{ or } 30 \text{ s}$; $T_H = 0.1 \text{ s}$; and Locked-Rotor Current = $6.00 \times \text{FLA}$.

An induction motor built to the NEMA MG 1 standard is capable of:

- two starts in succession (coasting to rest between starts) with the motor initially at ambient temperature (cold start)
- one start with the motor initially at a temperature not exceeding its rated-load operating temperature (hot start).

Since the connected load has a direct influence on motor heating during a start, NEMA MG 1 defines the load torque and the load inertia (Wk^2) for these starts as a function of the motor's rated power and synchronous speed. To satisfy the cold-start requirement, a start must not use more than 50% thermal capacity. To satisfy the hot-start requirement, used thermal capacity at steady state must be less than 50%.

If the thermal model in the MPS has the correct value of T_C and if $Used I^2t$ increases by 50% during a start, the load is equal to the NEMA-defined load and two starts from cold will be permitted. If $Used I^2t$ increases by more than 50% during a start, the load is greater than the NEMA-defined load and two starts from cold should not be permitted — a delay is required between starts. The appropriate delay can be obtained by enabling $I^2t \text{ Start Inhibit}$ and setting the $I^2t \text{ Inhibit Level}$ equal to 100% minus the I^2t used during a start (a slightly lower level is recommended to allow for supply and load variations). If $Used I^2t$ increases by less than 50% during a start, the load is less than the NEMA-defined load and two starts from cold will be permitted.

The magnitude of T_H relative to T_C determines if a hot start will be permitted if $I^2t \text{ Start Inhibit}$ is enabled and the $I^2t \text{ Inhibit Level}$ is set as described above. If $Used I^2t$ increases by 50% or less during a start, a hot start will be permitted if T_H is equal to or greater than 50% of T_C . Increasing T_H above 50% of T_C is not recommended unless specific information is available with respect to T_H .

5.2.3 EMERGENCY THERMAL RESET

OPI Menu: *Messages | Emerg I2t Reset | Reset I2t Memory*

Emergency Thermal Reset (ETR) sets $Used I^2t$ to 0%, resets starts-per-hour variables, and disables PTC and RTD temperature trips. Program access (password) is required. Disabled-temperature protection is indicated by $t^\circ \text{ Disabled by ETR}$ in the *Status Messages* display. If PTC or RTD temperature protection is not enabled, $t^\circ \text{ Disabled by ETR}$ will not be displayed. Stator RTD or PTC trips are reset when ETR is performed regardless of measured temperatures. Temperature protection must be re-enabled in the *Messages | Emerg I^2t Reset | Reenable Temp* menu, or by cycling supply voltage.

Temperature alarms and sensor verification remain enabled during ETR.

NOTE: Temperature protection is not automatically re-enabled after an Emergency Thermal Reset.

5.3 OVERCURRENT

OPI Menu: *Setup | Protection | Overcurrent*

Overcurrent protection is based on the largest fundamental-frequency component (DFT) of the three phase currents. An alarm-level setting is not provided.

When enabled, overcurrent protection is active at all times. It is not bypassed during a start.

- Trip Level1.00 to 15.00 x CT-Primary Rating (I_p)
- Trip Delay (TD).....0.00 to 10.00 s
(See Tables 5.1 and 5.2)
- Protection.....Enable/Disable Trip1, 2, 3
- Measurement MethodDFT

TABLE 5.1 TRIP TIME

FAULT LEVEL (multiples of trip-level setting) ⁽¹⁾	TRIP RELAYS (ms) (± 10 ms)	STARTER RELAYS (ms) (± 15 ms)
2	TD + 35	TD + 45
5	TD + 30	TD + 40
10	TD + 27	TD + 37
18	TD + 26	TD + 36

⁽¹⁾ For overcurrent faults less than $18 \times I_p$.
For earth faults less than $1 \times I_e$.

TABLE 5.2 FAULT DURATION REQUIRED FOR TRIP

FAULT LEVEL (multiples of trip-level setting) ⁽¹⁾	FAULT DURATION (ms)	
	TD ≤ 20 ms	TD > 20 ms
2	10	TD – 10
5	5	TD – 15
10	2	TD – 18
18	1	TD – 19

⁽¹⁾ For overcurrent faults less than $18 \times I_p$.
For earth faults less than $1 \times I_e$.

The asymmetrical-current multipliers for RMS and DFT measuring methods are shown in Fig. 5.2. X/R is the ratio of system reactance to system resistance. Typical X/R values are 6.6 for a low-voltage system, 15 for a medium-voltage system, and can be as high as 25 for a high-voltage system. As shown by the graph, the DFT filters the dc component so that the overcurrent setting can be set closer to the symmetrical fault value.

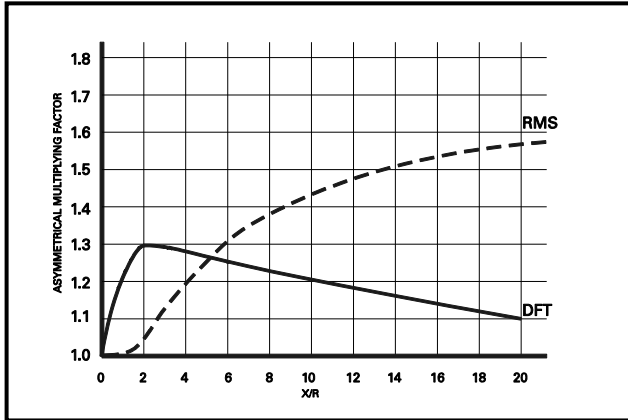

FIGURE 5.2 Asymmetrical-Current Multipliers.

5.4 AUXILIARY OVERCURRENT

OPI Menu: *Setup | Protection | Aux Overcurrent*

Auxiliary overcurrent is the same as overcurrent protection. This function is intended to be used when backup protection for the overcurrent function is required.

Trip Level1.00 to 15.00 x CT-Primary Rating (I_p)
 Trip Delay0.00 to 10.00 s
 (See Tables 5.1 and 5.2)
 ProtectionEnable/Disable Trip1, 2, 3
 Measurement MethodDFT

5.5 REDUCED OVERCURRENT

OPI Menu: *Setup | Protection | Reduced OC*

Reduced overcurrent is used to reduce the overcurrent set point when performing maintenance while a motor is running. This mode of operation can be used to meet *NEC 240.87 Arc Energy Reduction (B) (3) Energy-reducing maintenance switching with local status indicator*.

Reduced overcurrent is controlled by a digital input assigned to *Reduced OC*. When the digital input is not applied, this set point is operational and when the digital input is applied, this set point is not operational. When reduced overcurrent is selected, ROC:ON is displayed in the *Metering | System State* menu and a relay assigned to *Reduced OC* will be energized.

The Protection selection must include Trip1, Trip2, or Trip3. If *Disable* is selected, *Reduced OC* mode is disabled.

Trip Level1.00 to 15.00 x CT-Primary Rating (I_p)
 Trip DelayFixed at 0.00 (Instantaneous)
 See Tables 5.1 and 5.2
 ProtectionEnable/Disable Trip1, 2, 3
 Measurement MethodDFT

5.6 JAM

OPI Menu: *Setup | Protection | Jam*

A trip or alarm occurs if a jam condition is detected. Jam protection is active when the motor is in the Run mode, allowing protection to be set below motor-starting current.

Trip Level1.00 to 10.00 x FLA
 Trip Delay1.00 to 100.00 s
 Alarm Level1.00 to 10.00 x FLA
 Alarm Delay1.00 to 100.00 s
 ProtectionEnable/Disable Trip1, 2, 3
 Enable/Disable Alarm1, 2, 3
 Measurement MethodDFT

5.7 EARTH FAULT

OPI Menu: *Setup | Protection | Earth Fault*

Earth-fault protection is based on the fundamental-frequency component of zero-sequence current.

Trip Level0.05 to 1.00 x EF-CT-Primary Rating (I_e)
 Trip Delay0.00 to 100.00 s
 (See Tables 5.1 and 5.2)
 Alarm Level0.05 to 1.00 x I_e
 Alarm Delay0.00 to 100.00 s
 ProtectionEnable/Disable Trip1, 2, 3
 Enable/Disable Alarm1, 2, 3
 Measurement MethodDFT

5.8 CURRENT UNBALANCE

OPI Menu: *Setup | Protection | Unbalance (I)*

OPI Menu: *Setup | System Config | I_p Threshold*

Positive-sequence current (I_1) and negative-sequence current (I_2) are used to determine current unbalance (I_2/I_1). The unbalance display range is 0.00 to 1.00 where 1.00 is 100% unbalance—a single-phase condition. Negative unbalance will be indicated if current inputs are connected B-A-C. Severe unbalance may be indicated if phase-CT polarity is incorrect.

Lightly loaded systems, especially with synchronous motors, may cause false current unbalance trips. The I_p Threshold sets the current level where unbalance protection becomes active. The I_p Threshold is based on the maximum of the three-phase currents.

For example, if the CT-primary rating (I_p) is 100 A, and I_p Threshold is set to 0.25, current unbalance protection will be active above 25 A.

Trip Level	0.05 to 1.00
Trip Delay	1.00 to 100.00 s
Alarm Level	0.05 to 1.00
Alarm Delay	1.00 to 100.00 s
Protection	Enable/Disable Trip1, 2, 3 Enable/Disable Alarm1, 2, 3
I _p Threshold	0.10 to 0.50 x CT-primary rating (I _p)
Measurement Method	DFT

5.9 PHASE LOSS—CURRENT

OPI Menu: *Setup | Protection | Phase Loss (I)*

Phase loss is a severe form of unbalance. When phase loss occurs, negative-sequence current (I₂) is equal to positive-sequence current (I₁) and current unbalance is 100% or 1.00 pu. The phase-loss algorithm considers I₂/I₁ from 0.90 to 1.00 to be a phase loss. This occurs when one phase is open resulting in two current vectors at 180°. Set the phase-loss-trip delay lower than the unbalance trip delay to avoid an unbalance trip in the event of a phase loss.

NOTE: An open CT will result in I₂/I₁=0.5 because the phase angle between the other two phases remain at 120°. This is not considered a phase loss.

Trip Delay	1.00 to 100.00 s
Protection	Enable/Disable Trip1, 2, 3
Measurement Method	DFT

5.10 PHASE REVERSE—CURRENT

OPI Menu: *Setup | Protection | Phase Rev (I)*

If the current phase sequence is B-A-C, the magnitude of negative-sequence current will be larger than the magnitude of positive-sequence current.

Trip and Alarm Delay ⁽¹⁾	1.00 to 100.00 s
Protection	Enable/Disable Trip1, 2, 3 Enable/Disable Alarm1, 2, 3
Measurement Method	DFT

⁽¹⁾ Single set point applies to Trip and Alarm.

5.11 UNDERCURRENT

OPI Menu: *Setup | Protection | Undercurrent*

Undercurrent protection is loss-of-load protection and is active when the motor is in the Run mode. A trip or alarm is initiated if current remains below the set point for the programmed delay.

Trip Level	0.10 to 1.00 x FLA
Trip Delay	1.00 to 100.00 s
Alarm Level	0.10 to 1.00 x FLA
Alarm Delay	1.00 to 100.00 s
Protection	Enable/Disable Trip1, 2, 3 Enable/Disable Alarm1, 2, 3
Measurement Method	DFT

5.12 OVERVOLTAGE

OPI Menu: *Setup | Protection | Overvoltage*

A trip or alarm occurs if the maximum line-to-line voltage exceeds the set point.

Trip Level	1.00 to 1.40 x System Voltage Rating (V _p)
Trip Delay	1.00 to 500.00 s
Alarm Level	1.00 to 1.40 x V _p
Alarm Delay	1.00 to 500.00 s
Protection	Enable/Disable Trip1, 2, 3 Enable/Disable Alarm1, 2, 3
Measurement Method	DFT

5.13 VOLTAGE UNBALANCE

OPI Menu: *Setup | Protection | Unbalance (V)*

Positive-sequence voltage (V₁) and negative-sequence voltage (V₂) are used to determine voltage unbalance (V₂/V₁). The unbalance display range is 0.00 to 1.00 where 1.00 is 100% unbalance—a single-phase condition. A negative unbalance will be indicated if voltage inputs are connected B-A-C.

Trip Level	0.05 to 1.00
Trip Delay	1.00 to 100.00 s
Alarm Level	0.05 to 1.00
Alarm Delay	1.00 to 100.00 s
Protection	Enable/Disable Trip1, 2, 3 Enable/Disable Alarm1, 2, 3
Measurement Method	DFT

5.14 PHASE LOSS—VOLTAGE

OPI Menu: *Setup | Protection | Phase Loss (V)*

Phase loss is a severe form of unbalance. When phase loss occurs, negative-sequence voltage (V₂) is equal to positive-sequence voltage (V₁) and voltage unbalance is 100% or 1.00 pu. The phase-loss algorithm considers V₂/V₁ from 0.90 to 1.00 to be a phase loss. Set the phase-loss trip delay lower than the unbalance trip delay to avoid an unbalance trip in the event of a phase loss.

Trip Delay	1.00 to 100.00 s
Protection	Enable/Disable Trip1, 2, 3
Measurement Method	DFT

5.15 PHASE REVERSE—VOLTAGE

OPI Menu: *Setup | Protection | Phase Rev (V)*

If the voltage phase sequence is B-A-C, the magnitude of the negative-sequence voltage will be larger than the magnitude of the positive-sequence voltage.

Trip and Alarm Delay ⁽¹⁾	1.00 to 100.00 s
Protection	Enable/Disable Trip1, 2, 3 Enable/Disable Alarm1, 2, 3
Measurement Method	DFT

⁽¹⁾ Single set point applies to Trip and Alarm.

5.16 UNDERVOLTAGE

OPI Menu: *Setup | Protection | Undervoltage*

A trip or alarm occurs if the minimum line-to-line voltage is less than the set point.

Trip Level	0.50 to 1.00 x System Voltage Rating (V_p)
Trip Delay	1.00 to 500.00 s
Alarm Level	0.50 to 1.00 x V_p
Alarm Delay	1.00 to 500.00 s
Protection	Enable/Disable Trip1, 2, 3 Enable/Disable Alarm1, 2, 3
Measurement Method	DFT

5.17 UNDERPOWER

OPI Menu: *Setup | Protection | Underpower*

Apparent power (S) is defined by $S = P + jQ$. A trip or alarm is initiated when the real power (P) magnitude remains below the set point for the programmed delay. Protection is enabled when the motor is in the Run mode. See Section 7.2.

The Underpower setting is in per unit of rated power where 1.00 pu is defined as the *System Voltage x FLA Rating* x $\sqrt{3}$. The absolute value of power is used.

Trip Level	0.10 to 1.00
Trip Delay	0.50 to 500.00 s
Alarm Level	0.10 to 1.00
Alarm Delay	0.50 to 500.00 s
Protection	Enable/Disable Trip1, 2, 3 Enable/Disable Alarm1, 2, 3

5.18 REVERSEPOWER

OPI Menu: *Setup | Protection | Reversepower*

Apparent power (S) is defined by $S = P + jQ$. A trip or alarm is initiated when the real reverse power (P) magnitude (negative power) is higher than the set point for the programmed delay. See Section 7.2.

The Reversepower setting is in per unit of rated power where 1.00 pu is defined as the *System Voltage x FLA Rating* x $\sqrt{3}$. The magnitude of the negative power is used and protection is only active when negative power is detected.

Trip Level	0.10 to 1.00
Trip Delay	0.50 to 500.00 s
Alarm Level	0.10 to 1.00
Alarm Delay	0.50 to 500.00 s
Protection	Enable/Disable Trip1, 2, 3 Enable/Disable Alarm1, 2, 3

5.19 POWER FACTOR—QUADRANT 4

OPI Menu: *Setup | Protection | PF Quadrant4*

OPI Menu: *Setup | System Config | I_p Threshold*

A trip or alarm occurs if the absolute value of power factor in quadrant 4 is less than the set point. In quadrant 4, both Watts and Vars are positive (Importing).

Power-factor protection is active when the motor is in the Run mode. Run mode is defined in Section 5.1.

The I_p Threshold sets the point where power-factor protection becomes active.

Trip Level	0.50 to 1.00
Trip Delay	0.20 to 500.00 s
Alarm Level	0.50 to 1.00
Alarm Delay	0.20 to 500.00 s
I_p Threshold	0.10 to 0.50 x CT-primary rating (I_p)
Protection	Enable/Disable Trip1, 2, 3 Enable/Disable Alarm1, 2, 3

5.20 POWER FACTOR—QUADRANT 3

OPI Menu: *Setup | Protection | PF Quadrant3*

OPI Menu: *Setup | System Config | I_p Threshold*

A trip or alarm occurs if the absolute value of power factor in quadrant 3 is less than the set point. In quadrant 3, Watts are negative (Exporting) and Vars are positive (Importing).

Power-factor protection is active when the motor is in the Run mode. Run mode is defined in Section 5.1.

The I_p Threshold sets the point where power-factor protection becomes active.

Trip Level	0.50 to 1.00
Trip Delay	0.20 to 500.00 s
Alarm Level	0.50 to 1.00
Alarm Delay	0.20 to 500.00 s
I_p Threshold	0.10 to 0.50 x CT-primary rating (I_p)
Protection	Enable/Disable Trip1, 2, 3 Enable/Disable Alarm1, 2, 3

5.21 UNDERFREQUENCY

OPI Menu: *Setup | Protection | Underfrequency*

A trip or alarm occurs when the frequency of the input voltage (VA) is below the set point.

Underfrequency protection is inhibited when the input voltage is less than 50% of rated input (V_p).

Trip Level	30.00 to 80.00 Hz
Trip Delay	0.50 to 500.00 s
Alarm Level	30.00 to 80.00 Hz
Alarm Delay	0.5 to 500.00 s
Protection	Enable/Disable Trip1, 2, 3 Enable/Disable Alarm1, 2, 3

5.22 OVERFREQUENCY

OPI Menu: *Setup | Protection | Overfrequency*

A trip or alarm occurs when the frequency of the input voltage (VA) is above the set point.

Overfrequency protection is inhibited when the input voltage is less than 50% of rated input (V_p).

Trip Level	30.00 to 80.00 Hz
Trip Delay	0.50 to 500.00 s
Alarm Level	30.00 to 80.00 Hz
Alarm Delay	0.50 to 500.00 s
Protection	Enable/Disable Trip1, 2, 3 Enable/Disable Alarm1, 2, 3

5.23 STARTS PER HOUR / TIME BETWEEN STARTS

OPI Menu: *Setup | Protection | Starts Per Hour*

Starts-Per-Hour and Time-Between-Starts are useful limits in a protective relay that incorrectly responds to current below FLA. If the relay’s thermal model accurately tracks a motor’s used thermal capacity under all conditions, Starts-Per-Hour and Time-Between-Starts are features that provide no additional protection. The MPS does not require these features to provide protection, but they are included to satisfy protection strategies designed for protective relays without dynamic thermal modeling.

The Starts-Per-Hour feature ensures that the programmed number of starts per hour is not exceeded and the Time-Between-Starts feature ensures that the programmed time has elapsed between starts. The available number of starts and time between starts is also a function of the thermal model’s *Used I²t* value. Consequently, the allowed number of starts may be less than the starts-per-hour value and the time between starts may be longer than the set-point value.

The number of starts and time between starts is checked when the motor is stopped. A *Starts/Hour Trip* or *Starts/Hour Alarm* is issued if a start will exceed the # *Starts Per Hour* setting or if the time since the previous start is less than the *Time Between* setting.

When a *Starts/Hour Trip* or *Starts/Hour Alarm* is issued, the output relay assigned to *Start Inhibit* is energized. The *Start Inhibit* relay is non-latching and can be used as a start permissive. A *Starts/Hour Trip* will remain latched until a reset is issued. The *Start Inhibit* relay is shared with the thermal model’s *I²t Inhibit* feature.

If motor current is detected regardless of the alarm or trip condition, the *Starts/Hour Alarm* is removed, and *Starts/Hour Trip* can be reset. The starts-per-hour algorithm remains active but any trips or alarms are suppressed until the motor is stopped.

The status of Starts-Per-Hour and Time-Between-Starts is displayed in the *Metering | Thermal Capacity* menu. If there are no trips or alarms, the number of available starts (*Sph Available*) is displayed and if a trip or alarm is present, the inhibit time (*Sph Inhibit*) is displayed. Since

the *Metering | Thermal Capacity* menu is also used to display the thermal model status, messages are prioritized as follows:

- I^2t Reset Time⁽¹⁾
- I^2t Trip Time⁽¹⁾
- I^2t Inhibit Time⁽¹⁾
- Starts Per Hour Inhibit Time⁽³⁾
- Starts Available⁽²⁾⁽³⁾

An Emergency Thermal Reset (ETR) can be used to initialize all thermal and starts-per-hour variables and to reset a starts-per-hour trip. See Section 5.2.3.

Time Between Starts.....	0.00 to 500.00 Minutes
Starts Per Hour ⁽²⁾	1 to 10
Protection	Enable/Disable Trip 1, 2, 3 Enable/Disable Alarm 1, 2, 3

- (1) Calculated from thermal model data.
- (2) The display range for the number of available starts is -9 to +10.
- (3) Initialized when supply voltage is cycled.

5.24 FAILURE TO ACCELERATE AND UNDERSPEED

OPI Menu: *Setup | Protection | Underspeed*

OPI Menu: *Setup | 4-20 Analog In | Input Function*

OPI Menu: *Setup | Digital Inputs | Tachometer*

Failure-to-accelerate and underspeed protection are available if the MPS has a tachometer signal. The tachometer signal can originate from the High Speed Input (HSI) or the analog input. If the analog input is set to *Motor Speed*, it is used as the input to the algorithm, otherwise the digital tachometer (HSI) is used. The failure-to-accelerate algorithm is activated whenever a start is detected. Start detection is based on motor current. Set points 1 to 3 (for both speed and time) are sequentially checked to confirm acceleration.

Motor at Full Speed (refer to Type T28, Bit 2 in Appendix F) will be set when the measured tachometer speed exceeds the Speed 3 threshold setting and the Underspeed protection feature is enabled. If the Speed 3 threshold is not reached within Time 3, the MPS will trip on failure-to-accelerate.

While running, the tachometer signal is continuously measured and a trip occurs if the speed falls below the Speed 3 setting.

Time 1 must be set less than or equal to Time 2 and Time 2 must be set less than or equal to Time 3.

To enable display of the speed in the *Metering | System State* menu, select Enable in the *Setup | Digital Input | Tachometer | Enable/Disable* menu, when the HSI input is used.

Speed 1	1.00 to 100% Sync Speed
Time 1	1.00 to 1000.00 s
Speed 2	1.00 to 100% Sync Speed
Time 2.....	1.00 to 1000.00 s
Speed 3	1.00 to 100% Sync Speed
Time 3.....	1.00 to 1000.00 s
Protection.....	Enable/Disable Trip1, 2, 3

5.25 DIFFERENTIAL CURRENT PROTECTION

- OPI Menu: *Setup | Protection | Differential*
- OPI Menu: *Setup | Hardware | DIF Module*
- OPI Menu: *Setup | System Ratings | DF-CT Primary*

The MPS-DIF provides three-phase differential protection. It is intended to be used specifically for motor protection and not intended for feeder or transformer differential protection.

Enable the module and communications-loss protection using the *Setup | Hardware | DIF Module* menu. The module uses I/O module communications and both trip and alarm actions are available in the event of communications loss.

Set *DF-CT Primary* equal to the differential-CT-primary rating. For the MPS summation connection, *PH-CT Primary* and *DF-CT Primary* must be equal.

Trip and alarm settings are based on multiples of the *DF-CT Primary* rating (I_d).

Trip Level	0.10 to 15.00 x I_d
Trip Delay	0.00 to 10.00 s
Alarm Level	0.10 to 15.00 x I_d
Alarm Delay	0.00 to 10.00 s
Protection	Enable/Disable Trip1,2,3 Enable/Disable Alarm1,2,3
Measurement Method	DFT c/w CT saturation compensation.

5.26 PTC TEMPERATURE

- OPI Menu: *Setup | Protection | PTC Temperature*

A positive-temperature-coefficient (PTC) thermistor input is provided on the MPS-CTU. The total resistance of series-connected PTC thermistors must be less than 1,500 Ω at 20°C (68°F). A trip or alarm will occur when series resistance exceeds 2,900 Ω .

NOTE: During Emergency Thermal Reset, a PTC trip is reset and PTC-temperature protection is disabled. See Section 5.2.3.

Protection	Enable/Disable Trip1, 2, 3 Enable/Disable Alarm1, 2, 3
------------------	---

5.27 RTD TEMPERATURE

- OPI Menu: *Setup | Protection | RTD Temperature*
- OPI Menu: *Setup | Hardware | RTD Module*

Up to three RTD modules can be connected to the MPS-CTU. Select the number of modules in the *Setup | Hardware | RTD Modules* menu. Each module can monitor eight RTD's for a total of twenty-four RTD's. RTD type, function, and trip and alarm set points are programmable for each RTD.

When an RTD type is selected, trip and alarm functions are determined by Temperature Trip and Alarm settings.

During Emergency Thermal Reset, an RTD trip is reset and RTD-temperature protection is disabled. See Section 5.2.3.

RTD failure detection is provided. The actions for an RTD failure are selectable as *Trip1*, 2, or 3 and as *Alarm1*, 2, or 3. The selections apply to all RTD's.

The MPS supports three MPS-RTD modules with each module supporting eight RTDs. Each RTD can be assigned to one of eight function groups; *Stator*, *Bearing*, *Load*, *Ambient*, *Stator Voting*, *Bearing Voting*, *Load Voting*, and *Ambient Voting*. The specific assignment is set using the *Setup | Protection | RTD Temperature | Module x | Function* menu. Regardless of the assigned function, individual RTD trip and alarm setpoints remain active.

When an RTD is assigned to a voting group, it participates in the voting logic. Within a voting group, two RTDs must indicate a temperature above their trip setpoint in order to cause a trip. The first two RTDs that indicate a high temperature will generate a trip. Subsequent trips resulting from other RTDs in the group are not locked out. Trips must be individually reset and all trips must be reset to allow a start.

Failed sensors do not participate in the RTD voting logic. For example if six sensors are set to Stator Voting and two sensors fail, only four participate in RTD voting. When RTD voting is used, it is assumed that continuity of service is of high importance. In this case it is recommended to set the sensor-failure action to alarm only or to set the trip action to a value different than the Temperature Trip Action.

If only one RTD is assigned to a group, or if only one RTD is active because of sensor failures, RTD protection is the same as the corresponding non-voting function. RTD voting is not available for alarm setpoints.

RTD voting is contained within the specific function group and within the RTD module. An RTD in one module does not participate in the voting logic of another module.

Name	18 Character, Alphanumeric
Type	Disable, Pt100, Ni100, Ni120, Cu10
Function	Stator, Bearing, Load, Ambient, Stator Voting, Bearing Voting, Load Voting, Ambient Voting
Trip Range	40.00 to 200.00°C (104°F to 392°F)
Alarm Range	40.00 to 200.00°C (104°F to 392°F)
Display Range	-40.00 to 200.00°C (-40°F to 392°F)
Error Codes	-100 = No Sensor -90 = Open Sensor -80 = Shorted Sensor -70 = No Data/Module Error (Codes accessed via network communications)

5.28 HOT-MOTOR COMPENSATION

OPI Menu: *Setup | Protection | RTD Temperature*

If hot-motor compensation (HMC) is enabled, the maximum stator-RTD temperature is used to bias the thermal model by increasing *Used I²t* when the RTD temperature is greater than the thermal-model temperature.

Two set points are used to define the compensation. See Fig. 5.3. *HMC Minimum Bias* is the stator temperature where compensation begins at 0% *I²t*. *HMC Maximum Bias* is the stator temperature where compensation ends at 100% *I²t*.

Although the bias calculation is based on 0% and 100% *I²t* values, the *Used I²t* adjustment is limited to 90% *I²t*. An actual overload condition is required to cause a trip at 100% *I²t*.

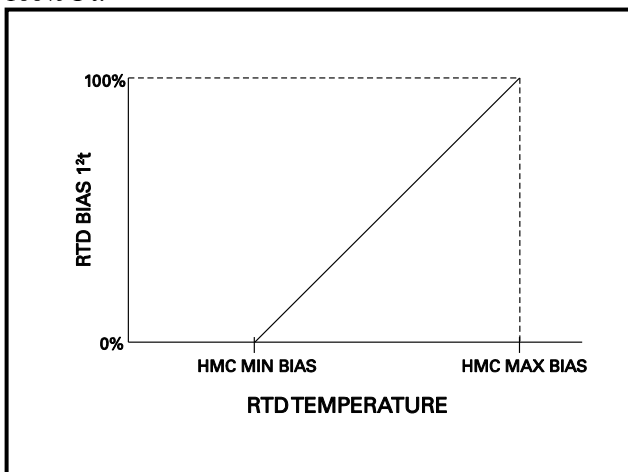

FIGURE 5.3 Used *I²t* Bias Curve.

HMC Minimum Bias40.00 to 200.00°C (104°F to 392°F)

HMC Maximum Bias40.00 to 200.00°C (104°F to 392°F)

ProtectionEnable/Disable

NOTE: Hot-motor compensation will not be active unless the *HMC High* set point is at least 10°C above the *HMC Low* set point.

5.29 ANALOG INPUT

OPI Menu: *Setup | Analog Input | 4-20 Input Type*

The analog input function is selectable as *Metering Only*, *Protection*, *Sync to ASD*, or *Motor Speed*.

5.29.1 PROTECTION

OPI Menu: *Setup | 4-20 Analog In | Protection*

The protection input has high-level and low-level trip and alarm set points. A high-level trip or alarm occurs when the 4-20-mA input exceeds the high-level trip or alarm set point, and a low-level trip or alarm occurs when the 4-20-mA input is lower than the low-level trip or alarm set point.

Trip action is fixed at *Trip1* and alarm action is fixed at *Alarm1*.

High Level Trip0.10 to 20.00 mA

Low Level Trip0.10 to 20.00 mA

Trip Delay0.01 to 100.00 s

High Level Alarm0.10 to 20.00 mA

Low Level Alarm0.10 to 20.00 mA

Alarm Delay0.01 to 100.00 s

5.29.2 SYNCHRONIZE TO ASD

OPI Menu: *Setup | 4-20 Analog In | Sync to ASD*

When *Sync to ASD* is selected, the MPS uses the 4-20-mA input to set the internal sampling rate for current and voltage inputs so that protection and metering functions use accurate RMS and DFT values from 10.00 to 70.00 Hz.

4-mA Frequency (lower)0.00 to 70.00 Hz

20-mA Frequency (upper)0.00 to 70.00 Hz

Frequency Range10.00 to 70.00 Hz

5.29.3 MOTOR SPEED

OPI Menu: *Setup | 4-20 Analog In | Motor Speed*

When the analog-input type is selected as *Motor Speed*, the 4-20-mA analog input is used as the speed input. This selection overrides the selections for the high-speed tachometer input and failure-to-accelerate protection uses the analog input as the source of speed information.

4-mA Speed0.00 to 100% Sync Speed

20-mA Speed0.00 to 100% Sync Speed

5.29.4 METERING ONLY

When the analog-input type is selected as *Metering Only*, an analog input does not affect MPS operation, but its value can be observed in the Metering menu and with a communications network.

6. STARTER FUNCTIONS

OPI Menu: *Setup | Starter*

6.1 GENERAL

All common starter types are supported. From the OPI *Starter Type* menu, select one of seventeen starter types or select *Protection Only*. Starter types requiring two FLA settings are indicated by the “*” symbol in the OPI display.

When *Protection Only* is selected, all starter functions except STOP are disabled and all OPI control-select LED’s will be off. Any STOP signal will initiate a *Trip1* when the MPS is in *Protection Only*.

NOTE: When *Protection Only* is selected, STOP will not function if *Trip1* is not assigned to a relay output.

When *Protection Only* is selected, the OPI STOP and RUN LED’s are controlled by motor current. When motor current is below the minimum Current Threshold defined in Section 3.2.1.2, the STOP LED is on and RUN LED is off. When motor current is above the minimum Current Threshold, the STOP LED is off and RUN LED is on. When a starter type is selected, the STOP and RUN LED’s are under starter control and not based on motor current.

When a starter type is selected, starter control can be performed with the digital inputs, OPI, or network communications. See Section 4.3.3 for details on selecting start sources.

Three control modes are available and selected using the OPI CONTROL SELECT key. In addition, a digital input can be used to select LOCAL. Each control mode has specific start sources that can be programmed as shown in Table 6.1. REMOTE control can be configured to operate with start sources from the digital input, OPI and the network. OPI Control uses the OPI start keys as the start sources. LOCAL control uses the Local Start1 or Local Start2 start sources or the OPI. In LOCAL mode, OPI control can be enabled or disabled. Control selection is indicated by the REMOTE, OPI, and LOCAL LED’s on the OPI.

The digital inputs allow concurrent operation of three start-control methods; 3-wire start/stop, 2-wire start/stop, and 3-wire local start/stop. Three-wire control requires two digital inputs, one programmed for *Start1* or *Start2* (N.O. momentary start switch) and one programmed for *Stop* (N.C. momentary stop switch) as shown in Fig. 6.1. Two-wire control uses one input, programmed as *2-Wire Start1* or *2-Wire Start2*, for start/stop control and can be used where a single contact provides start/stop operation. See Fig. 6.2. If a start was activated by a 2-wire start input, any other STOP will initiate a latching *Trip1*. In all other cases, STOP does not cause a trip.

Digital inputs programmed for *Limit1 Stop* and *Limit2 Stop* are used to provide stop control for *Start1* and *Start2*. This is typically used in reversing starter applications. The forward-direction limit switch is connected to the *Limit1 Stop* input and the reverse-direction limit switch is connected to the *Limit2 Stop* input.

With this control method, a *Start1* requires limit switch 1 to be closed and limit switch 2 is ignored. In a similar manner, *Start2* requires, limit switch 2 to be closed while limit switch 1 is ignored.

NOTE: When starter functions are used, protective functions with the trip action set to *Trip1* will cause the starter to stop when a trip occurs. Reset is required.

Table 6.1 indicates the available start sources.

TABLE 6.1 START-SOURCE SUMMARY ⁽¹⁾

CONTROL ⁽⁷⁾ SELECTION	START SOURCE	
REMOTE ⁽²⁾	DIGITAL INPUTS ⁽³⁾	Start1 Input (3-wire control) Start2 Input (3-wire control)
		2-W Start1 (2-wire control) ⁽⁴⁾ 2-W Start2 (2-wire control) ⁽⁴⁾
	OPI ⁽³⁾	START1 Key START2 Key
	NETWORK ⁽³⁾	Start1 Command Start2 Command
OPI	OPI START1 Key OPI START2 Key	
LOCAL ⁽⁵⁾⁽⁶⁾	DIGITAL INPUTS	Local Start1 (3-wire) Local Start2 (3-wire)
	OPI ⁽⁸⁾	START1 Key START2 Key

⁽¹⁾ All STOP sources are always enabled.

⁽²⁾ Factory default has all sources enabled and REMOTE selected.

⁽³⁾ Can be enabled or disabled using the *Setup | Starters | Remote Group* menu.

⁽⁴⁾ STOP causes a latching trip.

⁽⁵⁾ LOCAL can also be selected by a network command or by a digital input programmed for *Local Select*. Each *Local Select* source must de-select local control for the MPS to return to the previous control setting.

⁽⁶⁾ *Pt Start Inhibit*, *Starts per Hour* alarms and *Interlocks* are bypassed.

⁽⁷⁾ At least one Control Selection must be enabled even when *Protection Only* is selected.

⁽⁸⁾ Can be enabled or disabled using the *Setup | Starters | Local Group* menu.

Up to four timers (*Stage 1 to 3 Delay*, and *Start Time*) control the start sequence. These timers control *Starter RLYA*, *Starter RLYB*, *Starter RLYC*, and *Starter RLYD* as shown in the timing diagrams in Section 6.2. These functions can be assigned to any output relay. Digital

inputs can be programmed to monitor contactor status. Contactor status corresponding to *Starter RLYA*, *Starter RLYB*, *Starter RLYC*, and *Starter RLYD* outputs are designated as *RLYA Status*, *RLYB Status*, *RLYC Status*, and *RLYD Status*. The MPS will issue a *Trip1* and indicate *Relay Status Trip* if the status contact does not follow within 500 ms of the command to operate the respective relay output. In addition, a transition must not occur prior to its intended time.

When the starting sequence is complete, contactor status is checked every 500 ms and a *Relay Status Trip* will occur if the status changes.

NOTE: Relay Status is not checked when the starter is in the stopped state.

The *Start Time* set point is the maximum start time allowed. The starting process will terminate and generate a *Trip1* unless current is between $1.5 \times (\text{CT-Primary Rating} / \text{FLA})$ and $125\% \text{ FLA}$ when the *Start Time* timer times out.

In reduced-voltage-starting applications, the MPS can use time-based or current-based transfer from the starting to the running connection. The transfer type is selected as *Time Transfer* or *Current Transfer* using the *Transfer Type* menu.

When *Current Transfer* is selected, the start-connection delay (*Stage 1 Delay* or *Stage 2 Delay*, see Table 6.2 and Figs 6.5, 6.6, 6.7, and 6.8) defines the minimum starting-connection time. The transfer to the run connection occurs when the start-connection delay has expired and current is below the *Transfer Current*. When current is above the *Transfer Current*, the transfer will be delayed up to the maximum time defined by the *Start Time*. If current is below $1.5 \times (\text{CT-Primary Rating} / \text{FLA})$ when the start-connection delay expires or if the *Start Time* is exceeded, the MPS will issue a *Trip1* and indicate *Starter Trip*.

When *Time Transfer* is selected, the start-connection delay set point (*Stage 1 Delay* or *Stage 2 Delay*) is used to determine the transfer time. Transfer to the run connection occurs after the start-connection delay has expired.

In both current- and time-transfer modes, the MPS will issue a *Trip1* and indicate *Starter Trip* if load current is above $125\% \text{ FLA}$ or below $1.5 \times (\text{CT-Primary Rating} / \text{FLA})$ when the *Start Time* expires. The *Start Time* set point must be long enough to allow the starting sequence to complete and for the motor current to drop below $125\% \text{ FLA}$.

Table 6.2 summarizes starter types and shows which starter set points are active.

The backspin timer is available when a delay is required between starts. The backspin timer is enabled in the *BkSpin En/Disable* menu, and the delay time is set in the *Backspin Delay* menu. The backspin timer is

activated by a STOP or when supply voltage is cycled on the MPS. While the backspin timer is on, the *Backspin Timer On* message is displayed in the *Status Message* menu and starts are not allowed.

The connection diagrams, Figs. 6.9 to 6.23, show typical control circuits with 120-Vac contactor coils and the 24-Vdc source on the MPS-CTU used for status contacts. Other supply voltages can be used within the limits of the digital-input and relay-contact ratings. The use of status contacts is optional.

NOTE: Stop and start control, electrical interlocks, and mechanical interlocks are not shown in connection diagrams.

NOTE: Connection diagrams show typical output relay assignments that must be set using the *Setup | Relay Outputs | Relay x | Relay x Function* menu.

NOTE: To cancel a long backspin time, enter new backspin parameters and restart the MPS using the *Setup | System Config | Maintenance | Restart MPS-CTU* menu or cycle supply voltage.

TABLE 6.2 STARTER SUMMARY

STARTER TYPE	SEQ. NO.	TIMERS USED ⁽¹⁾	START-CONNECTION TIMER NUMBER ⁽¹⁾	ACTIVE FLA SETPOINTS ⁽²⁾		RELAYS AND CONTACTOR STATUS ⁽³⁾			
				FLA	FLA 2	RLYA	RLYB	RLYC	RLYD
Full-Voltage Non-Reversing	1	4		x		x			
Adjustable-Speed Drive	1	4		x		x			
Soft-Start	1	4		x		x			
Full-Voltage Reversing	2	4		x		x	x		
Two-Speed Two-Winding	2	4		x	x	x	x		
Reactor or Resistor Closed-Transition ⁽⁴⁾	3	1,4	1	x		x	x		
Slip-Ring ⁽⁴⁾	3	1,4	1	x		x	x		
Part-Winding ⁽⁴⁾	3	1,4	1	x	x	x	x		
Double-Delta ⁽⁴⁾	3	1,4	1	x	x	x	x		
Soft-Start-with-Bypass ⁽⁴⁾	3	1,4	1	x		x	x		
Reactor or Resistor Open-Transition ⁽⁴⁾	4	1,4	1	x		x	x		
Two-Winding ⁽⁴⁾	4	1,4	1	x	x	x	x		
Wye-Delta Open-Transition ⁽⁴⁾	5	1,2,3,4	2	x	x	x	x	x	
Autotransformer Closed-Transition ⁽⁴⁾	5	1,2,3,4	2	x		x	x	x	
Wye-Delta Closed-Transition ⁽⁴⁾	6	1,2,4	2	x	x	x	x	x	x

⁽¹⁾ TIMERS
1: Stage 1 Delay
2: Stage 2 Delay
3: Stage 3 Delay
4: Start Time

⁽²⁾ FLA SETPOINTS
FLA: Full-Load Current
FLA2: Full-Load Current 2

⁽³⁾ RELAYS AND CONTACTOR STATUS
Starter RLYA, Starter RLYB, Starter RLYC, and Starter RLYD are not automatically assigned. The user must assign these functions to individual relays. Status is assignable to any digital input.

⁽⁴⁾ Current transfer capability when enabled

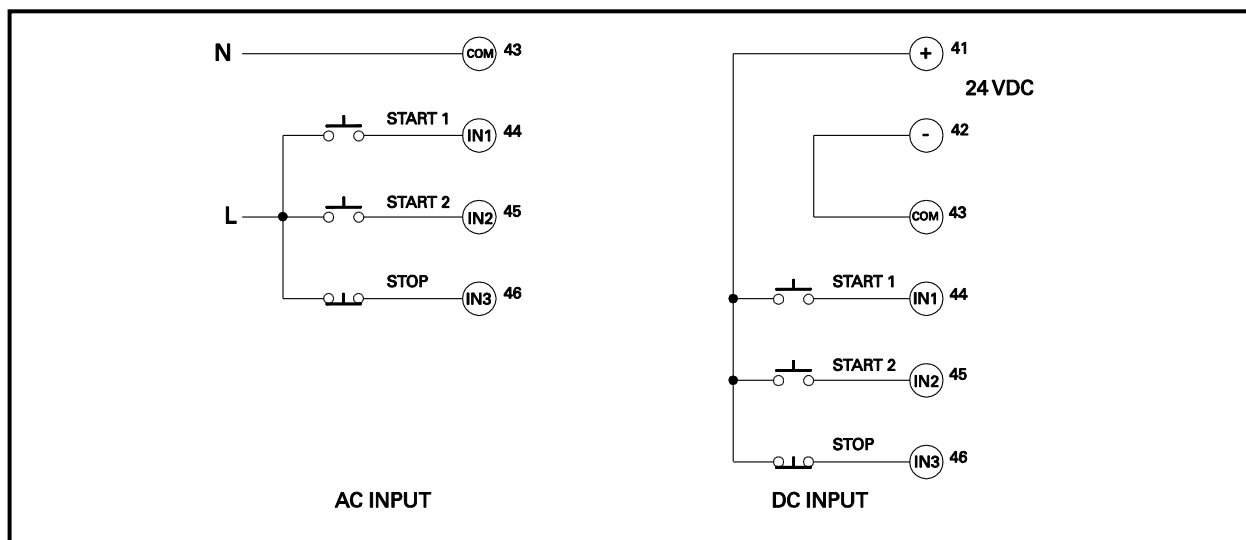

FIGURE 6.1 Typical 3-Wire Control.

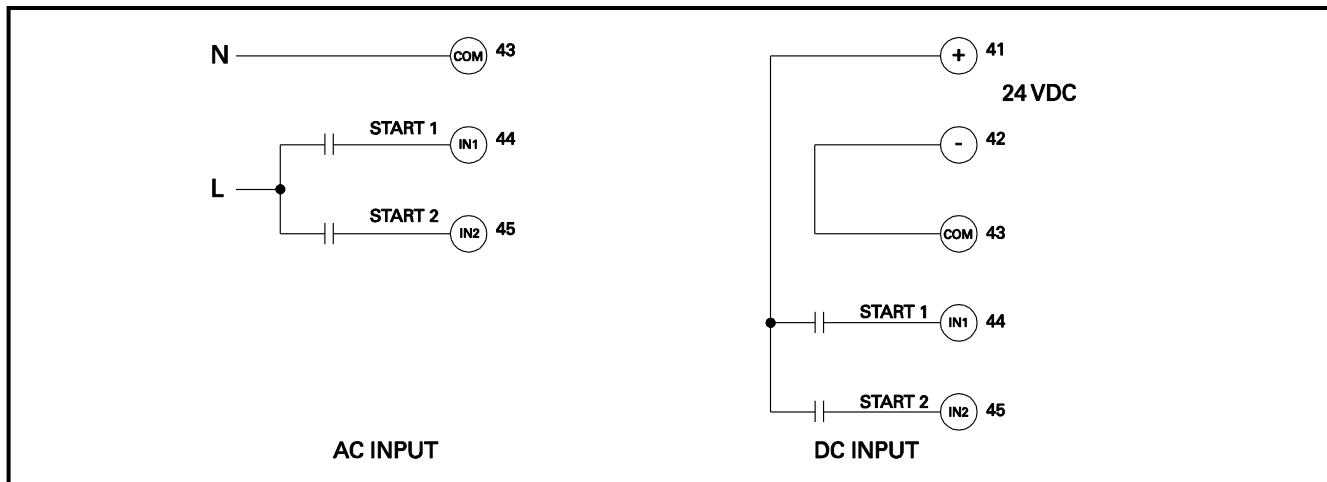

FIGURE 6.2 Typical 2-Wire Control.

6.2 STARTER TIMING SEQUENCES

The MPS uses one of six timing sequences to implement the various starter types. These time-based starter sequences are shown in Figs. 6.3 to 6.8.

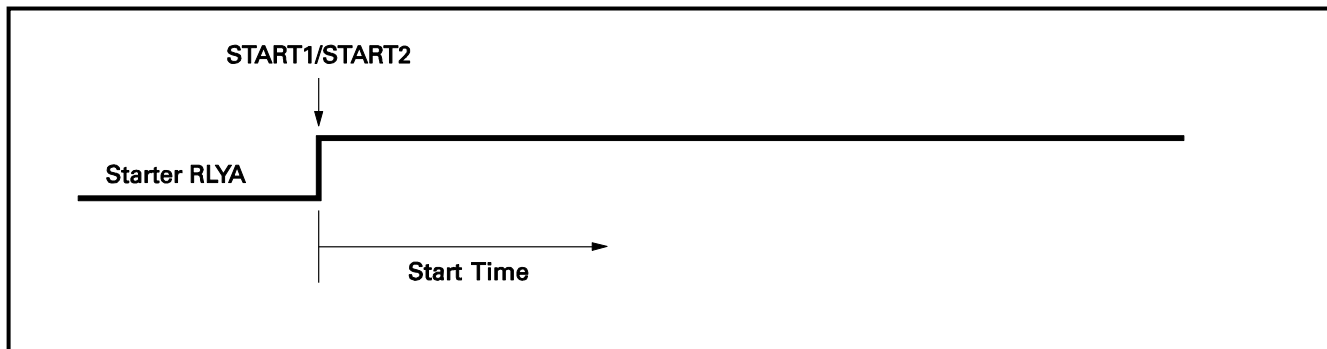

FIGURE 6.3 Starter Sequence 1.

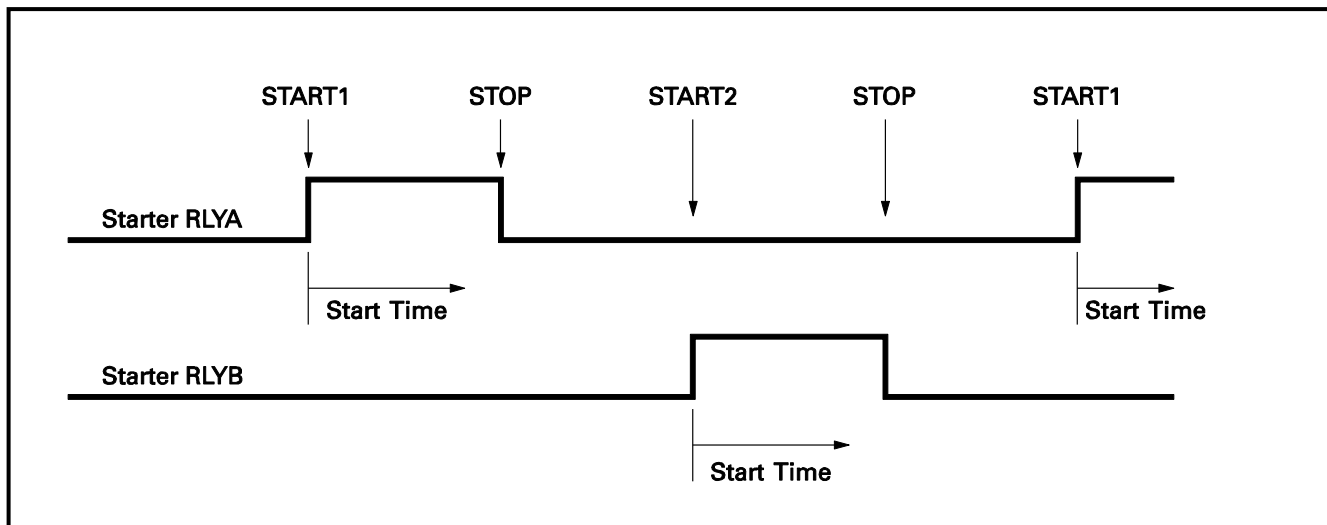

FIGURE 6.4 Starter Sequence 2.

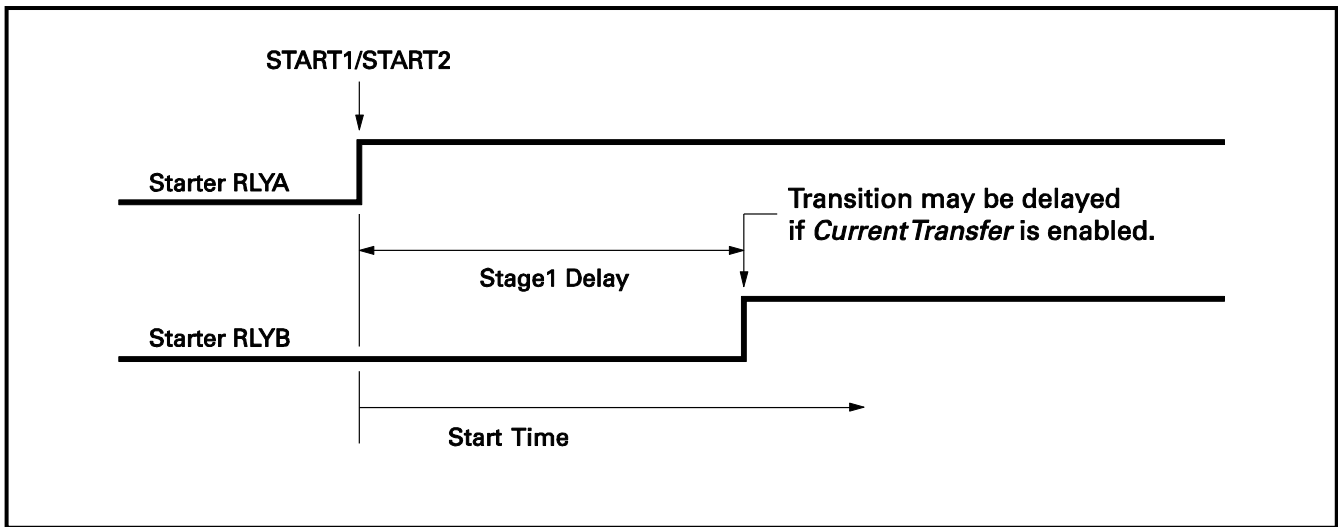

FIGURE 6.5 Starter Sequence 3.

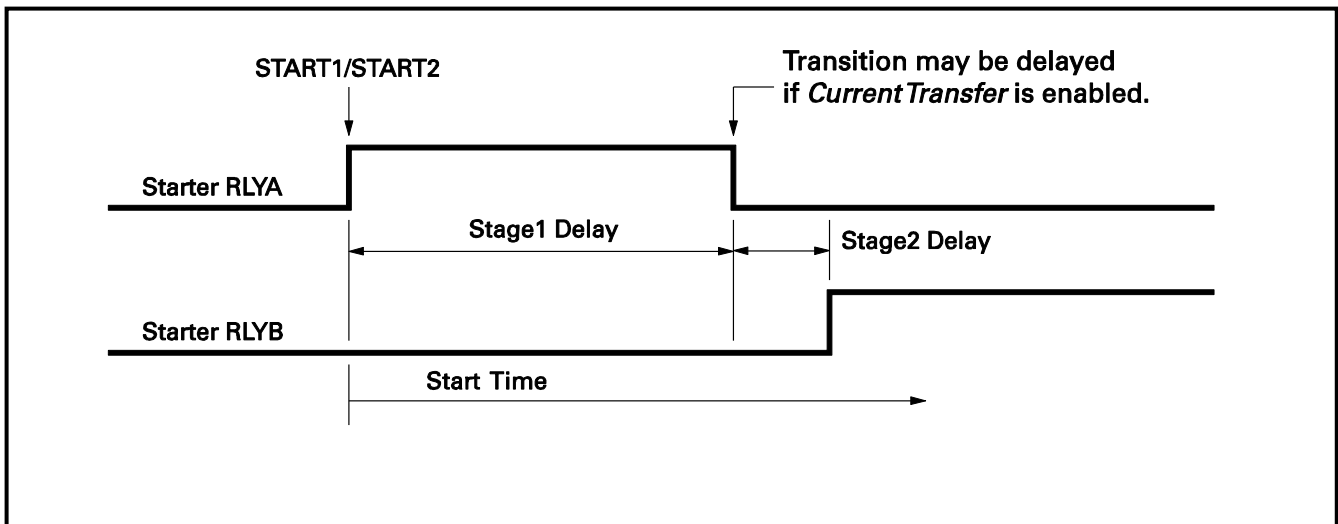

FIGURE 6.6 Starter Sequence 4.

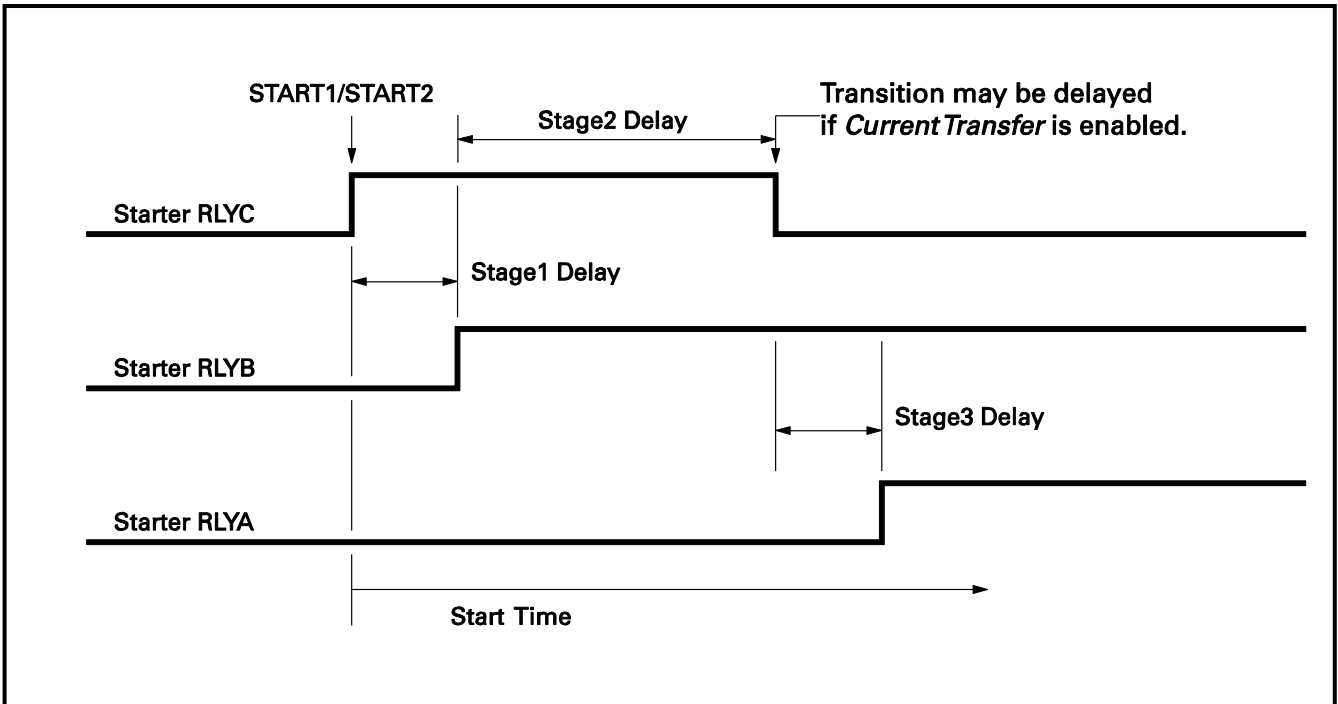

FIGURE 6.7 Starter Sequence 5.

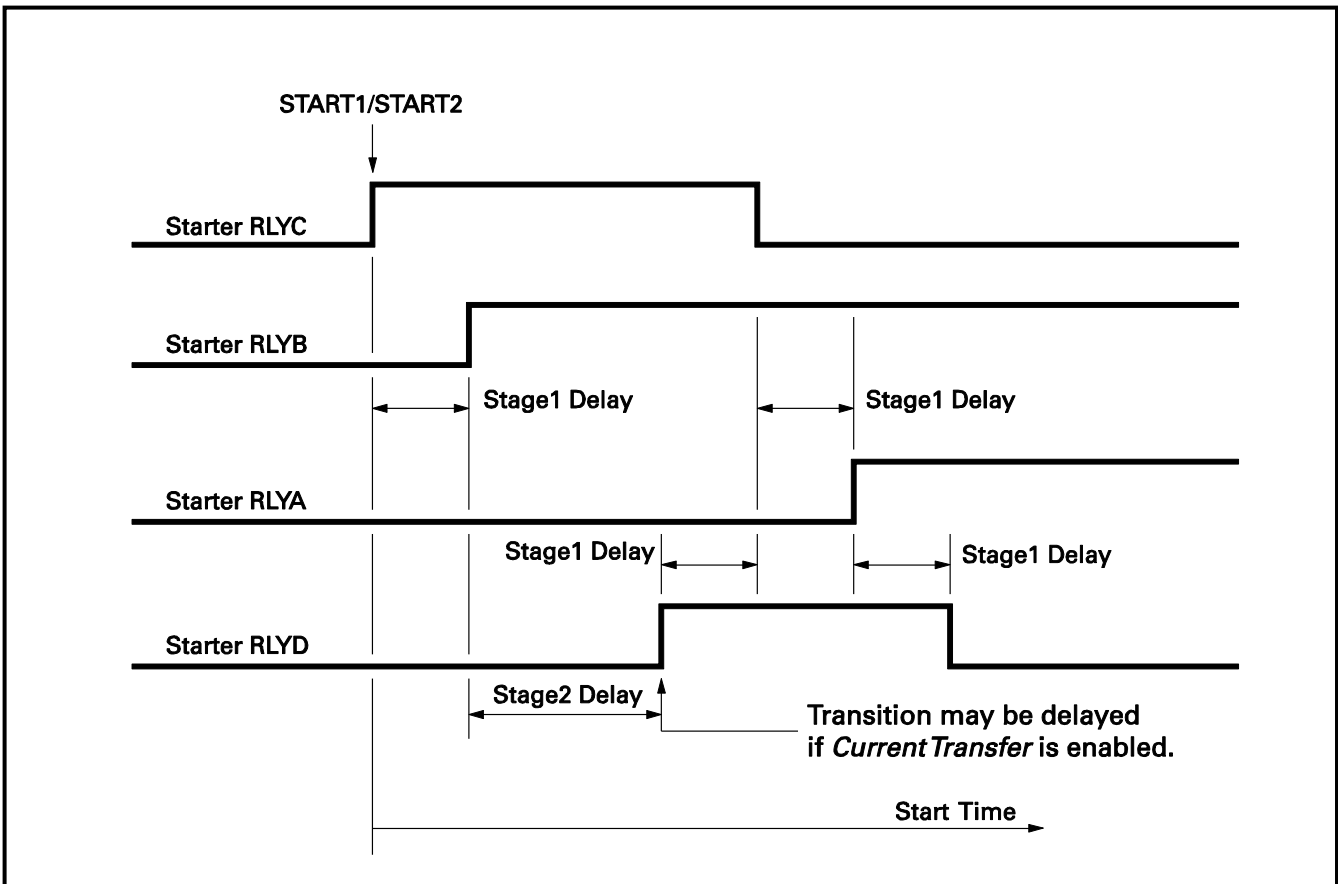

FIGURE 6.8 Starter Sequence 6.

6.3 FULL-VOLTAGE NON-REVERSING STARTER

Sequence: Fig. 6.3
Connection: Fig. 6.9
Current Transfer: Not available

START1 or START2 is the start command and *Starter RLYA* is used as the output to control the contactor.

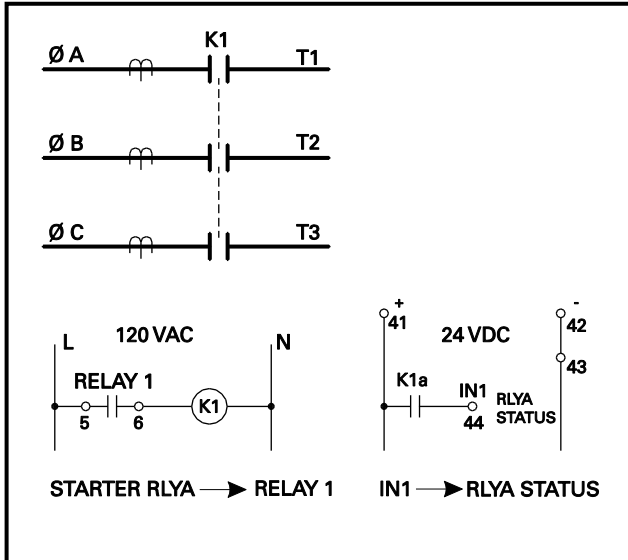

FIGURE 6.9 Full-Voltage Non-Reversing-Starter Connection.

6.4 ADJUSTABLE-SPEED DRIVE

Sequence: Fig. 6.3
Connection: Fig. 6.10
Current Transfer: Not available

The MPS-CTU provides the start input to an adjustable-speed drive (ASD). START1 or START2 is the start command and *Starter RLYA* is used as the output to control the ASD.

The MPS-CTU has a 4-20 mA input that should be used to synchronize its sampling rate to the ASD output frequency so that all protection and metering values are valid for an ASD output frequency from 10 to 70 Hz. In ASD applications, voltage and current inputs must be derived from the load side of the ASD, and undervoltage protection must be disabled.

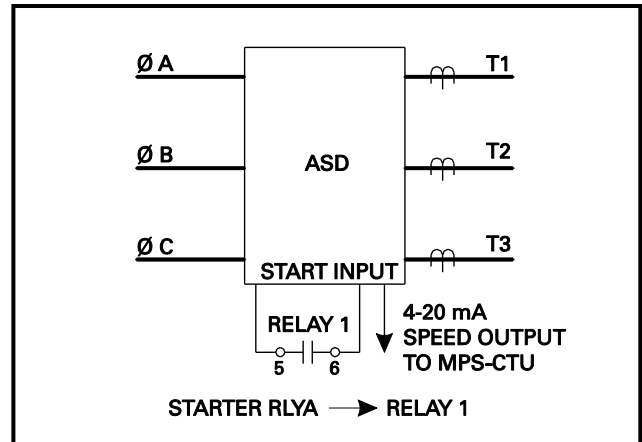

FIGURE 6.10 Adjustable-Speed-Drive Connection.

6.5 SOFT-START STARTER

Sequence: Fig. 6.3
Connection: Fig. 6.11
Current Transfer: Not available

The MPS-CTU provides the start input to a solid-state starter. START1 or START2 is the start command and *Starter RLYA* is used as the output to control the starter.

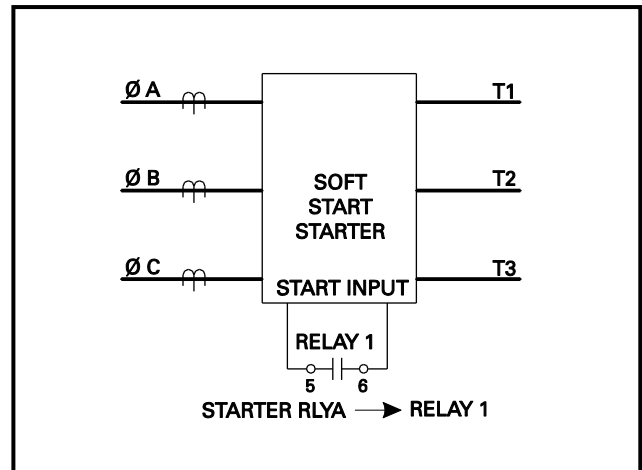

FIGURE 6.11 Soft-Start-Starter Connection.

6.6 FULL-VOLTAGE REVERSING STARTER

Sequence: Fig. 6.4
Connection: Fig. 6.12
Current Transfer: Not available

The full-voltage reversing starter uses START1 to activate *Starter RLYA* for forward control and START2 to activate *Starter RLYB* for reverse control. *RLYA Status* is the status corresponding to *Starter RLYA* and *RLYB Status* is the status corresponding to *Starter RLYB*.

For OPI and 3-wire start/stop control, a direction change requires a STOP command prior to a START1 or START2 command. For 2-wire control a STOP command is not required.

Fig. 6.12 shows the use of forward and reverse limit switches. When *Start1* is issued, K1 is energized. If a STOP is issued or LSF opens, K1 is de-energized. Provided LSR is closed, *Start2* will energize K2 to allow operation in the reverse direction.

NOTE: Phase CT's should be located upstream of the contactors.

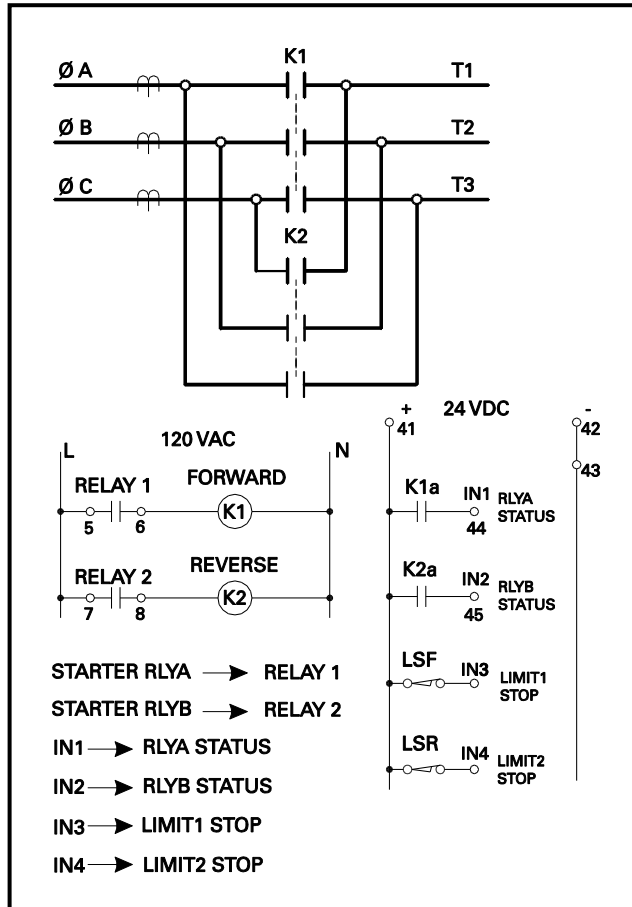

FIGURE 6.12 Full-Voltage-Reversing-Starter Connection.

6.7 TWO-SPEED STARTER

Sequence: Fig. 6.4
Connection: Fig. 6.13, 6.14, and 6.15
Current Transfer: Not available

The two-speed starter uses START1 to activate *Starter RLYA* for high-speed control and START2 to activate *Starter RLYB* for low-speed control. *RLYA Status* is the status corresponding to *Starter RLYA* and *RLYB Status* is the status corresponding to *Starter RLYB*. A speed change requires a STOP command prior to a START1 or START2 command. This starter can be used on motors with two separate windings (Fig. 6.13) or on motors with reconnectable windings (Figs. 6.14 and 6.15).

This starter requires two FLA settings. Use *FLA Rating* for the high-speed connection and *FLA Rating 2* for the low-speed connection.

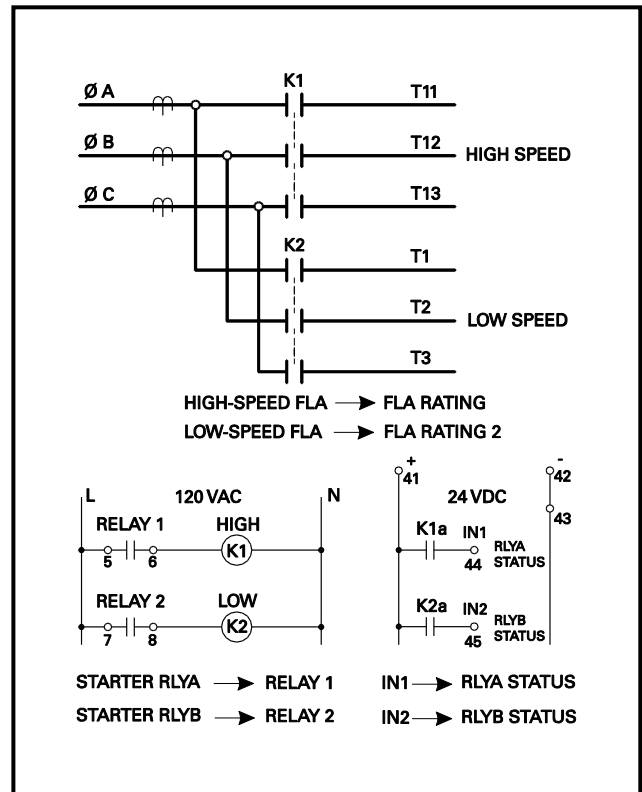

FIGURE 6.13 Two-Speed Two-Winding-Starter Connection.

6.8 REACTOR OR RESISTOR CLOSED-TRANSITION STARTER

Sequence: Fig. 6.5
Connection: Fig. 6.16
Current Transfer: Available

This starter uses a reactor or resistor to provide reduced-voltage starting and the reactor or resistor contactor (K1) remains closed during running.

START1 or START2 initiates the starting sequence by activating *Starter RLYA*. *Starter RLYB* activates after the *Stage1 Delay*.

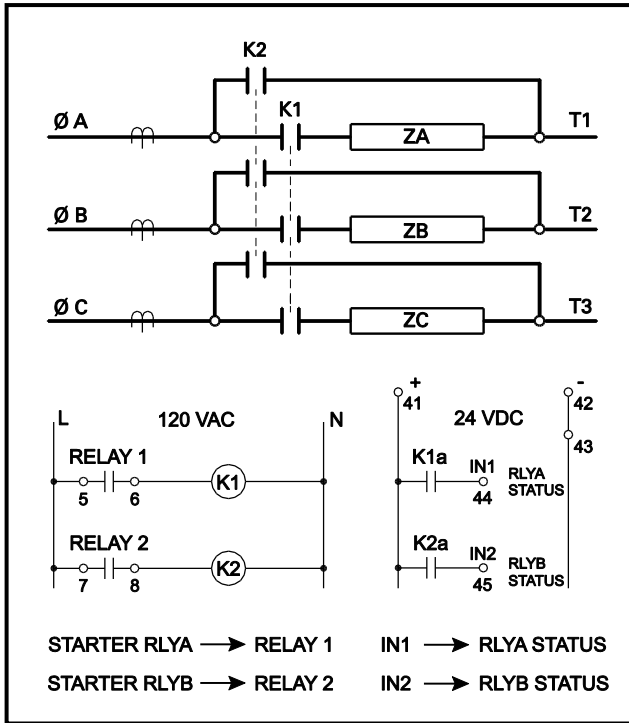

FIGURE 6.16 Reactor or Resistor-Starter Connection.

6.9 SLIP-RING STARTER

Sequence: Fig. 6.5
Connection: Fig. 6.17
Current Transfer: Available

The slip-ring starter is a single-stage wound-rotor starter with a single contactor (K2) controlling the rotor resistor bank.

START1 or START2 initiates the starting sequence by activating *Starter RLYA*. *Starter RLYB* activates after the *Stage1 Delay*.

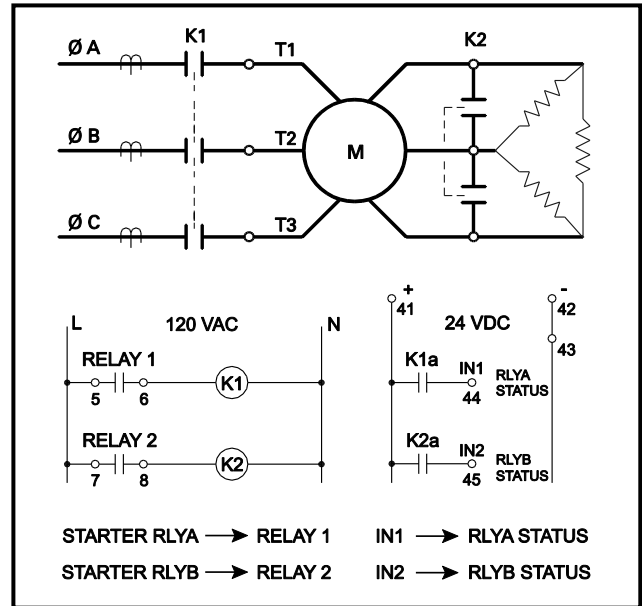

FIGURE 6.17 Slip-Ring-Starter Connection.

6.10 PART-WINDING AND DOUBLE-DELTA STARTERS

Sequence: Fig. 6.5
Connection: Fig. 6.18
Current Transfer: Available

The part-winding starter is used on motors with two stator windings and the double-delta starter has a delta winding that is parallel connected during running.

START1 or START2 initiates the starting sequence by activating *Starter RLYA*. *Starter RLYB* activates after the *Stage1 Delay*.

Both starters require two FLA settings. *FLA Rating 2* is the full-load current for the starting connection and *FLA Rating* is the full-load current for the running connection.

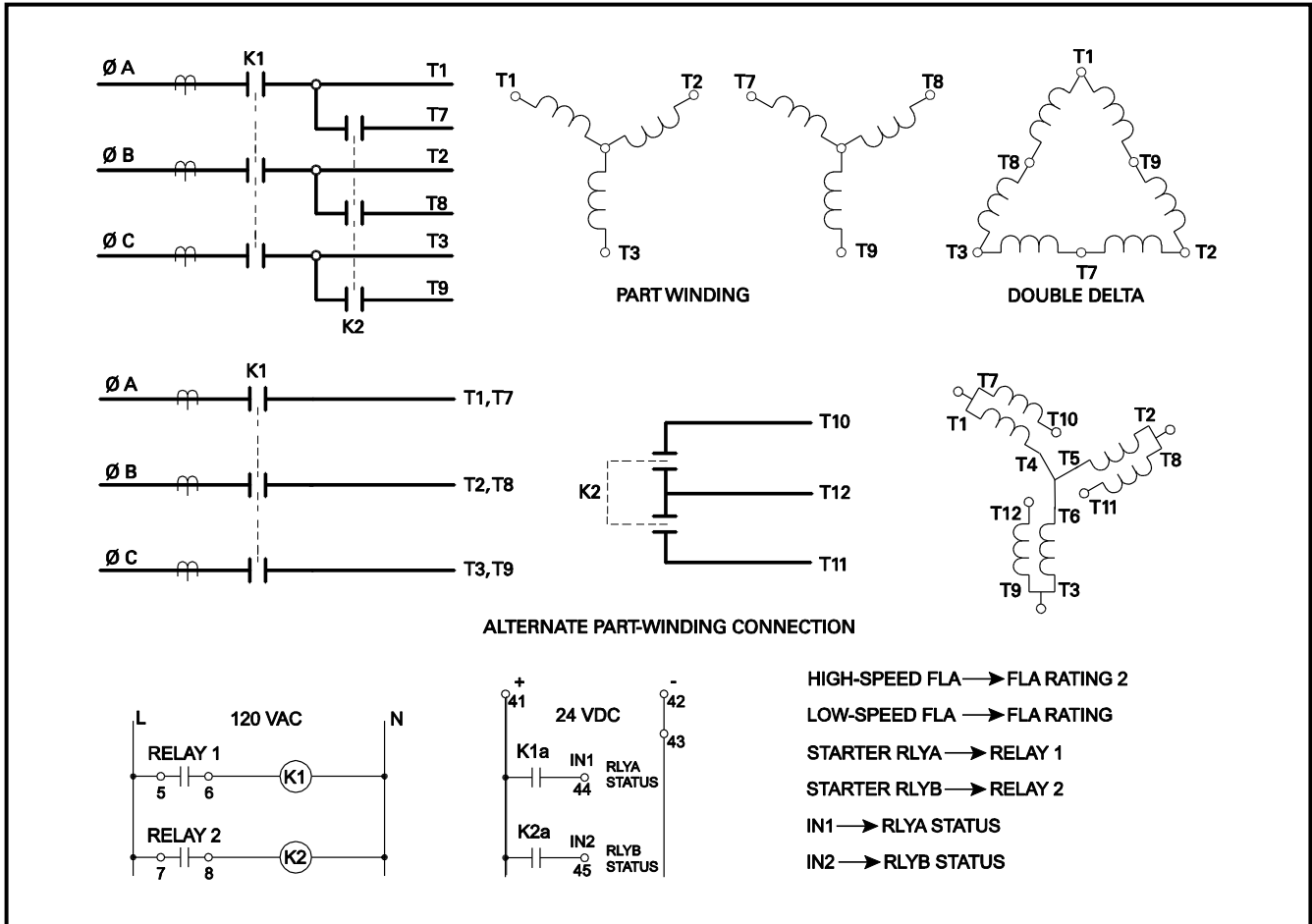

FIGURE 6.18 Part-Winding and Double-Delta-Starter Connections.

6.11 SOFT-START-WITH-BYPASS STARTER

Sequence: Fig. 6.5
Connection: Fig. 6.19
Current Transfer: Available

START1 or START2 initiates the starting sequence by activating *Starter RLYA*. *Starter RLYB* activates after the *Stage1 Delay* to close the bypass contactor.

Although *RLYA Status* can be selected as a digital input, it is not usually available for this starter.

For a soft-start where the bypass function is included, a bypass signal from the soft-start can be used as an input to the MPS. There are two solutions:

- 1) This option coordinates the MPS *Starter RLYB* signal with the soft-start and ensures the status input does not validate prior to the intended time. Assign an MPS output relay with the *Starter RLYB* function as per Fig. 6.19. Connect this output-relay contact in series with the bypass contact from the soft-start (K1a) and connect this signal to a digital input programmed as *RLYB Status*. Set the *Stage 1 Delay* longer than the soft-start bypass time.
- 2) This option uses a digital input programmed as *Trip1* in conjunction with the MPS trip-bypass feature. Connect the bypass signal from the soft-start to a digital input assigned as *Trip1*. Enable *Trip Bypass* and set the *Bypass Delay* longer than the start time of the soft-start. Note that this feature is based on current and during a stop requires the input to remain valid until current is not detected. If the soft-start has a ramp-down feature, set the *INx Trip Delay* greater than the ramp-down time to prevent a trip when the soft-start stops. See Section 4.2.8.

6.12 REACTOR OR RESISTOR OPEN-TRANSITION STARTER

Sequence: Fig. 6.6
Connection: Fig. 6.16
Current Transfer: Available

START1 or START2 activates *Starter RLYA* for the duration of the *Stage1 Delay*. After *Starter RLYA* de-activates for the *Stage2 Delay*, *Starter RLYB* activates.

6.13 TWO-WINDING STARTER

Sequence: Fig. 6.6
Connection: Fig. 6.20
Current Transfer: Available

This starter is an open-transition starter for two-winding motors that run with only one winding energized.

START1 or START2 activates *Starter RLYA* for the time specified by the *Stage1 Delay*. After *Starter RLYA* de-activates for the *Stage2 Delay*, *Starter RLYB* activates.

This starter requires two full-load current set points. *FLA Rating 2* is the full-load current for the starting connection (*Starter RLYA*) and *FLA Rating 1* is the full-load current for the running connection (*Starter RLYB*).

6.14 WYE-DELTA OPEN-TRANSITION STARTER

Sequence: Fig. 6.7
Connection: Fig. 6.21
Current Transfer: Available

START1 or START2 initiates the sequence. *Starter RLYC* activates to close the neutral contactor (K3). *Starter RLYB* activates the wye contactor (K2) after the *Stage1 Delay*. *Starter RLYC* de-activates to open the neutral contactor after the *Stage2 Delay* and *Starter RLYA* activates to close the delta contactor (K1) after the *Stage3 Delay*. Stage-1 and Stage-3 delays are contactor-transfer times and should be set in the range of 0.1 to 0.5 seconds.

Locate CT's on the line side of the starter.

This starter uses two full-load current settings. Set *FLA Rating 1* to the delta full-load current and *FLA Rating 2* to the wye full-load current.

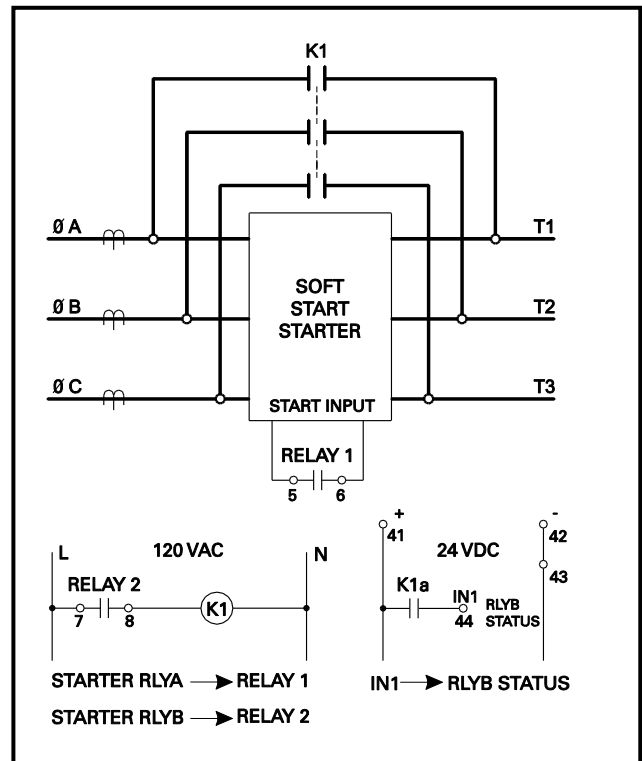

FIGURE 6.19 Soft-Start-With-Bypass-Starter Connection.

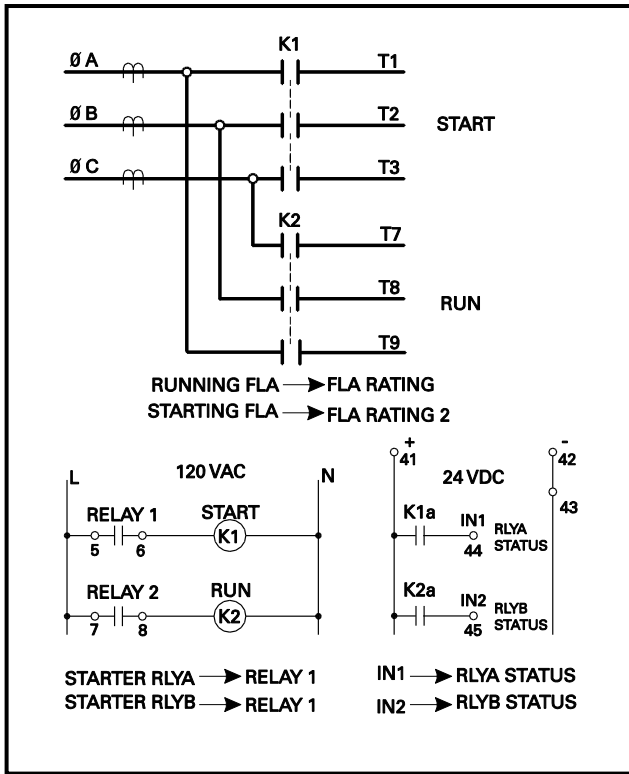

FIGURE 6.20 Two-Winding-Starter Connection.

6.15 AUTOTRANSFORMER CLOSED-TRANSITION STARTER

Sequence: Fig. 6.7
 Connection: Fig. 6.22
 Current Transfer: Available

START1 or START2 initiates the sequence. *Starter RLYC* activates to close the neutral contactor (K3) on the autotransformer. *Starter RLYB* activates to close the main autotransformer contactor (K2) after the *Stage1 Delay*. *Starter RLYC* de-activates to open the autotransformer neutral contactor after the *Stage2 Delay*, and *Starter RLYA* activates to close the main motor contactor (K1) after the *Stage3 Delay*. Stage-1 and Stage-3 delays are contactor-transfer times and should be set in the range of 0.1 to 0.5 seconds.

6.16 WYE-DELTA CLOSED-TRANSITION STARTER

Sequence: Fig. 6.8
 Connection: Fig. 6.23
 Current Transfer: Available

START1 or START2 initiates the start sequence. *Starter RLYC* activates to close the neutral contactor (K3). *Starter RLYB* activates to close the wye contactor (K2) after the *Stage1 Delay*. *Starter RLYD* activates to close the resistor contactor (K4) after the *Stage2 Delay*. This is followed by de-activation of *Starter RLYC*, activation of *Starter RLYA* to close the main motor contactor (K1), and de-activation of *Starter RLYD*, all displaced by the *Stage1 Delay*.

Locate CT's on the line side of the starter. Set *FLA Rating* to the delta full-load current and *FLA Rating 2* to the wye full-load current. Stage-1 delay is a contactor-transfer time and should be set in the range of 0.1 to 0.5 seconds.

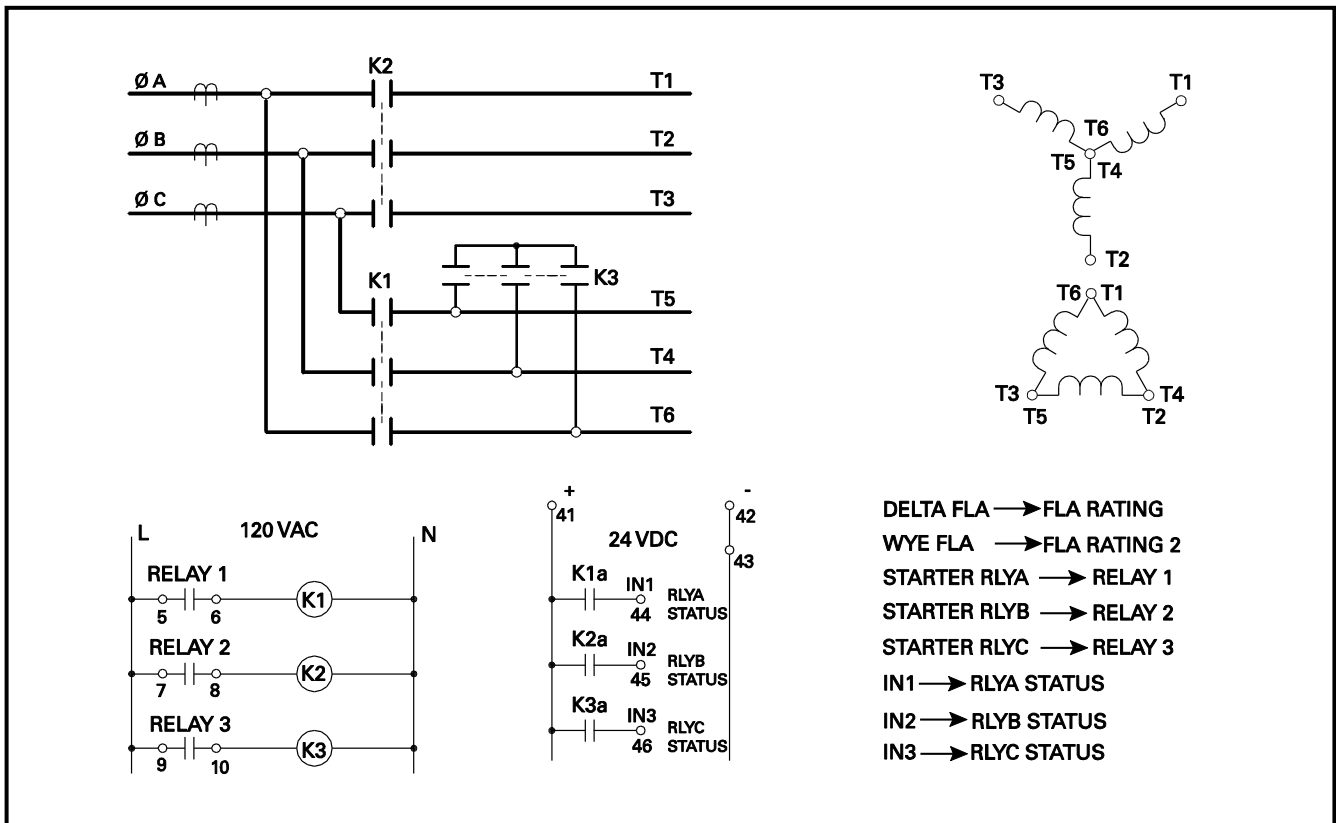

FIGURE 6.21 Wye-Delta Open-Transition-Starter Connection.

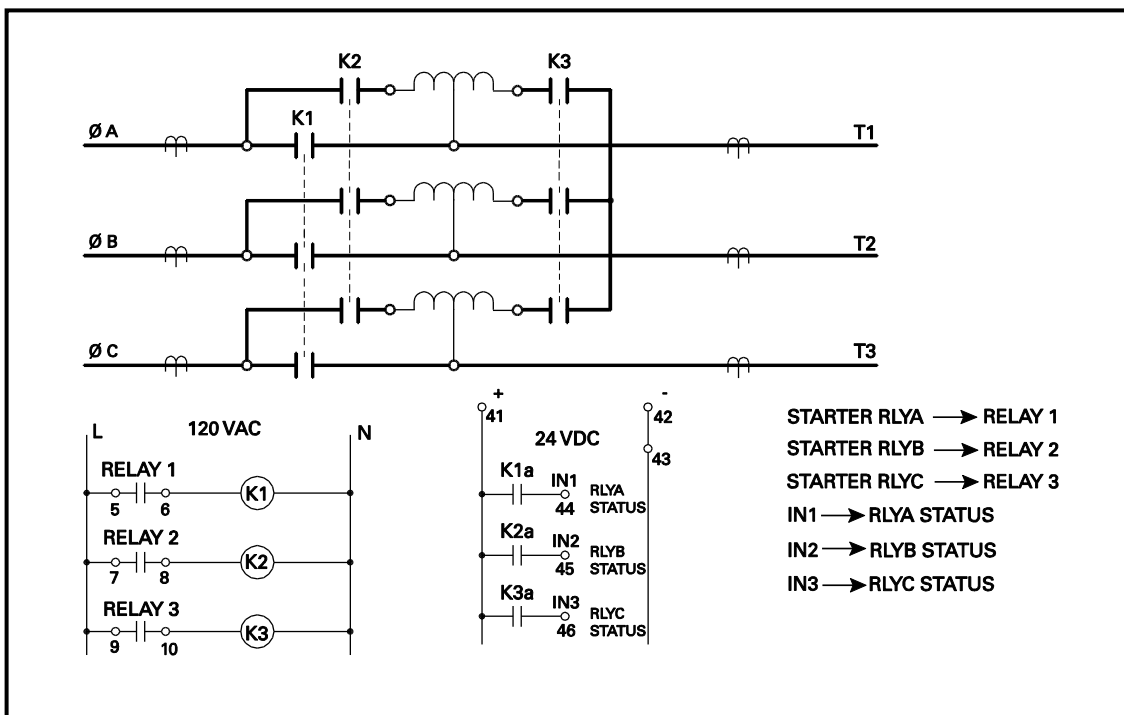

FIGURE 6.22 Autotransformer Closed-Transition-Starter Connection.

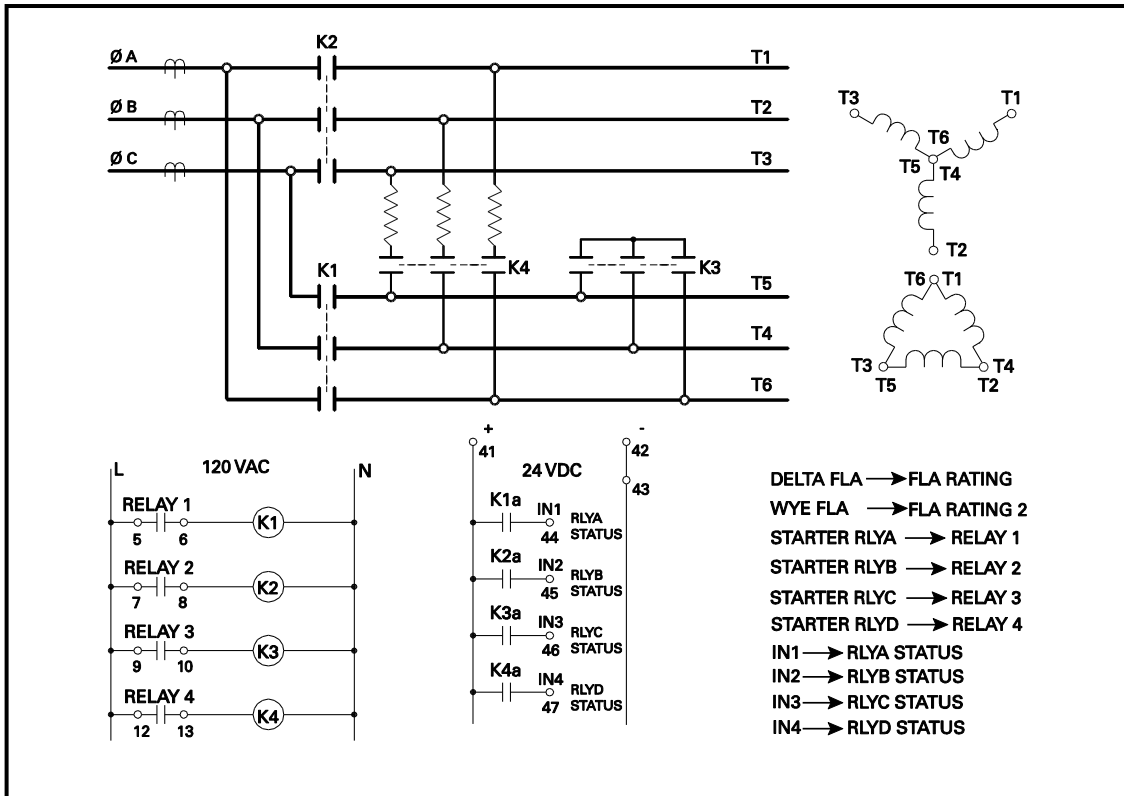

FIGURE 6.23 Wye-Delta Closed-Transition-Starter Connection.

This page intentionally left blank.

7. THEORY OF OPERATION

7.1 SIGNAL-PROCESSING ALGORITHMS

The sampling frequency of the MPS is variable. It can be set for 50-Hz, 60-Hz, or variable-frequency applications. The MPS obtains sixteen samples per cycle of each current and voltage signal. For an adjustable-speed drive (ASD) application, a speed or frequency output from the ASD can be connected to the 4-20-mA input to synchronize the sampling rate to the ASD output frequency. This maintains accurate measurements of power and sequential components.

The sampling rate is sixteen samples per cycle of the fundamental frequency. A Discrete-Fourier-Transform (DFT) algorithm is used to obtain the magnitude and phase angles of the fundamental-frequency components of the current and voltage waveforms. These values provide true positive- and negative-sequence components. True RMS values of line currents are calculated for use by the thermal-model algorithm. RMS values include up to the 8th harmonic. All calculated values are updated at the sampling frequency to achieve a fast response to fault conditions. RMS values of the fundamental components of current and voltage are displayed.

The MPS uses the input voltage VA for frequency measurement. The input voltage must be above 30 Vac and a sixteen-cycle interval is used to determine frequency. Frequency protection is inhibited when system voltage is less than 50% of the *System Voltage* setting.

7.2 POWER ALGORITHM

Apparent power (*S*) is calculated by:

$$S = P + jQ$$

Real power (*P*) is determined from the in-phase components of *I* and *V*, and reactive power (*Q*) is determined from the quadrature components of *I* with respect to *V*. Power factor is the magnitude of the ratio of *P* to *S*.

The one-PT connection assumes balanced voltages for power calculations. Power calculations for the other connections are valid for both balanced and unbalanced conditions. In all cases, power calculations use the two-wattmeter method and assume 3-wire loads.

The IEEE convention is used for power displays:

- +Watts, +Vars, -PF (Lag) Importing Watts,
Importing Vars
- +Watts, -Vars, +PF (Lead) Importing Watts,
Exporting Vars
- Watts, -Vars, -PF (Lag) Exporting Watts,
Exporting Vars
- Watts, +Vars, +PF (Lead) Exporting Watts,
Importing Vars

7.3 OPERATOR INTERFACE (MPS-OPI)

The OPI is a terminal device used to communicate with the MPS-CTU. All set points, operating parameters, and menus are stored in the MPS-CTU.

The OPI contains a microprocessor used to communicate with the MPS-CTU, read key presses, and perform display functions.

On multiple-OPI systems, all OPI's display the same information. Key presses on any OPI will be processed by the MPS-CTU.

7.4 RTD MODULE (MPS-RTD)

The RTD module contains a microprocessor, A/D converter, and analog multiplexers used to measure up to eight RTD's. The RTD-measuring circuit is isolated from the I/O Module network. All eight RTD's are scanned every three seconds. RTD linearization, open/short detection, and lead compensation are performed by the RTD module. RTD temperature is sent to the MPS-CTU where temperature monitoring occurs.

7.5 DIFFERENTIAL MODULE (MPS-DIF)

The differential module obtains 32 samples per cycle of the differential current. A Discrete-Fourier-Transform (DFT) algorithm is used to obtain the magnitude of the three differential currents. Frequency of operation is set by the MPS-CTU unit and allows differential protection to be used in variable-frequency drive applications. The DFT values are sent to the MPS-CTU where differential protection is performed.

7.6 FIRMWARE DIAGNOSTICS

Starting with firmware 2.01, diagnostic error handling has been added. In the event of an internal fault, a diagnostic error code is generated and can be viewed with the OPI. The last error code can be viewed by selecting *Setup | System Config | Maintenance | Firmware Version*. The diagnostic code is a two or three digit hexadecimal number.

02 to FF:	Processor Fault
100:	Protection-Algorithm Fault
200:	Relay-Control Algorithm Fault
300:	Starter-Control Fault
400:	Menu-Display Fault
500:	OPI-Key-Handler Fault
600:	Real-Time Clock Fault
700:	Communication-Handler Fault
800:	RTD Temperature-Handler Fault
900:	A/D Communication-Interface Fault

The last diagnostic error code is saved in non-volatile memory. The diagnostic code is overwritten by any new codes but can also be manually set to zero. To clear the error code, press RESET while in the *Firmware Version* menu.

When upgrading an MPS that did not previously support the diagnostic error code, the initial value of the diagnostic code is not valid and should be cleared.

A diagnostic error generates a Trip1 and increments the trip counter; however, a trip record is not generated.

8. COMMUNICATIONS

8.1 PERSONAL-COMPUTER INTERFACE

8.1.1 FIRMWARE UPGRADE

The MPS-CTU control program is stored in flash memory. Field updates can be made through the I/O module communications connection. The following are required:

- A Windows® PC with the SE-Flash program installed
- A file containing the MPS-CTU control program (.s19 file)
- An RS-232/RS-485 converter that operates at 57,600 bit/s. Use the Littelfuse Startco SE-485-PP or SE-485-DIN.

SE-Flash is available at www.littelfuse.com/relayscontrols.

8.1.2 SE-COMM-RIS

SE-Comm-RIS is a Windows-based program used to access MPS functions with a personal computer (PC) via the RS-485 network interface or Modbus® TCP⁽¹⁾. Use SE-Comm-MPS to program an MPS either by changing individual set points or by downloading set-point files. Existing MPS set points can be transferred to the PC. Metered values can be viewed simultaneously and the MPS can be controlled with the computer. SE-Comm-RIS extends the event-record storage capability of the MPS by allowing the user to transfer data to PC memory at a programmable interval. Protection curve plotting capability is included. SE-Comm-RIS is available at www.littelfuse.com/relayscontrols.

⁽¹⁾ Requires Ethernet option and firmware 2.50 or higher.

8.2 NETWORK INTERFACE

Each MPS-CTU is equipped with an RS-485 interface and can be optionally equipped with a DeviceNet, Ethernet, or Profibus interface. Communications interfaces are mutually exclusive; only one can be used at a time.

For detailed information see Appendices in this manual and applicable communications manuals.

8.2.1 RS-485 COMMUNICATIONS

SE-485 communications support Modbus® RTU and Allen Bradley® DF1 half-duplex protocols. All set points and meter values are accessible. Commands are provided to perform trips, resets, and starter control.

Modbus® RTU function codes supported:

- Read Holding Registers (Code 3)
- Read Input Registers (Code 4)
- Write Single Register (Code 6)
- Write Multiple Registers (Code 16)
- Command Instruction (Code 5)

DF1 Commands Supported

- Unprotected Read (CMD = 01)
- Unprotected Write (CMD = 08)
- Typed Read (CMD = 0F, FNC = 68)
- Typed Write (CMD = 0F, FNC = 67)
- Typed Logical Read (CMD = 0F, FNC = A2)
- Typed Logical Write (CMD = 0F, FNC = AA)

8.2.2 DEVICENET COMMUNICATIONS

DeviceNet™ communications support Explicit Messaging and Polled I/O. All set points and meter values are accessible using Explicit Messaging. The Polled I/O connection supports the following ODVA input assemblies:

- Basic Overload (50)
- Extended Overload (51)
- Basic Motor Starter (52)
- Extended Motor Starter 1 (53)
- Extended Motor Starter 2 (53)

In addition to the ODVA assemblies, a user-configurable fixed block of 64 bytes is available.

The Polled I/O connection supports the following ODVA Output assemblies:

- Basic Overload (2)
- Basic Motor Starter (3)
- Extended Contactor
- Extended Motor Starter

An Electronic Data Sheet (EDS) file is provided for use with DeviceNet configuration tools such as RSNetWorx and DeltaV.

8.2.3 ETHERNET COMMUNICATIONS

The MPS supports Modbus® TCP and Ethernet/IP using the Anybus-S module from HMS Fieldbus Systems AB. Data from the MPS consists of a 64-byte assembly representing user-defined register data. A command structure is provided to write set-point and MPS commands.

Starting with firmware 2.50, Modbus® TCP provides access to all MPS registers and supports SE-Comm-RIS.

8.2.4 PROFIBUS COMMUNICATIONS

The MPS supports Profibus-DP using the Anybus-S module. Data from the MPS consists of a 64-byte assembly representing user-defined register data. A command structure is provided to write set-point and MPS commands.

This page intentionally left blank.

9. TECHNICAL SPECIFICATIONS

9.1 CONTROL UNIT (MPS-CTU)

Supply25 VA, 120 to 240 Vac
(+10, -45%),
40 to 400 Hz, power
factor corrected;
25 W, 110 to 250 Vdc
(+10, -25%)

Power-Up Time.....800 ms at 120 Vac

Ride-Through Time100 ms minimum

24-Vdc Source ⁽¹⁾100 mA maximum

AC Measurements:

MethodsTrue RMS and DFT,
Positive- and negative-
sequence components of
the fundamental
Sample Rate16 samples/cycle

Frequency:

Fixed.....50, 60 Hz
Variable10 to 70 Hz, sync via
4-20 mA signal from
ASD

Phase-Current Inputs: ⁽²⁾

Range.....18 x CT-Primary Rating
(I_p)

Accuracy: ⁽³⁾

$I < I_p$ 1% I_p
 $I > I_p$ 1% Reading

Burden< 0.01 Ω

Unbalance Accuracy0.01 pu

Common-Mode Voltage.....120 Vac maximum

Thermal Withstand:

Continuous.....5 x I_p
1-Second80 x I_p

Earth-Leakage Input:

Range.....1.5 x Earth-Fault-CT-
Primary Rating (I_e)

Accuracy ⁽³⁾1% I_e

Burden< 0.01 Ω (1- and 5-A
inputs), 10 Ω for EFCT

Common-Mode Voltage.....120 Vac maximum

Thermal Withstand:

Continuous.....5 x I_e
1-Second80 x I_e

Phase-Voltage Inputs: ^(4,5)

Nominal Input30 to 600 Vac line-to-line

Input Resistance3.4 M Ω

Range.....1.4 x PT-Primary Rating
(V_p)

Voltage-Input Fuse0.3 A, Class CC
Littelfuse KLKR.300

Voltage-Input Wire⁽⁹⁾18 AWG to 14 AWG
(0.82 to 2.08 mm²), 600 V

Accuracy: ⁽³⁾

$V < V_p$ 1% V_p

$V > V_p$ 1% Reading

Unbalance Accuracy0.01 pu

Frequency Metering:

Range.....5 to 100 Hz,
Uses VA input,
Sine wave assumed
Accuracy0.05 Hz

PTC-Thermistor Input: ⁽¹⁾

Cold Resistance1500 Ω maximum at 20°C
(68°F)

Trip Level.....2,800 Ω \pm 100 Ω

Sensor Current.....2 mA maximum

4-20 mA Analog Input:

Input Burden.....100 Ω

Common-Mode

Voltage ⁽⁶⁾ \pm 5 Vdc

4-20 mA Analog Output: ⁽¹⁾

Load.....500 Ω maximum

Range.....0 to 25 mA

Update Time500 ms

Tachometer Input: ⁽⁷⁾

Type.....Active pickup, 24-V logic
output, sourcing, PNP
output
TURCK Bi1.5-EG08-
AP6X-V1131 or
equivalent

Pulses Per Revolution1 to 120

Pulse Frequency10 Hz to 10 kHz

Accuracy1%

Timing Accuracies: ⁽⁸⁾

Set Points.....-10%, + 0%
(minimum 25 to 45 ms)

OverloadGreater of 2% or
+ 200 ms (minimum 25 to
45 ms)

Starter-Control Stop Time:

Digital Input	30 to 80 ms
OPI	70 to 200 ms
Network	30 to 80 ms

Relay Contacts (Relays 1 and 2):

Configuration	N.O. (Form A)
CSA/UL Contact Rating	8 A resistive 250 Vac, 5 A resistive 30 Vdc

Supplemental Contact Ratings:

Break:	
dc	200 W resistive,
ac	3,040 VA resistive,
	1,000 VA inductive
	(PF = 0.4)
Subject to maximums of 8 Aac and 5 Adc,	
250 V (ac or dc).	

Relay Contacts (Relays 3 and 4):

Configuration	N.O. and N.C. (Form C)
CSA/UL Contact Rating	8 A resistive 250 Vac, 8 A resistive 30 Vdc

Supplemental Contact Ratings:

Make/Carry	30 A, 0.2 s
Rating Code	B300
Break:	
dc	50 W resistive, 150 Vdc
ac	2,500 VA resistive,
	360 VA inductive
	(PF = 0.4)
Subject to maximums of 8 A and 250 V (ac or dc).	

Solid-State Output (Relay 5):

Configuration	N.O. (Form A)
Rating	100 mA, 250 V (ac or dc)
On Resistance	30 Ω maximum

Digital Inputs: ⁽¹⁾

Range	24 to 130 V (ac or dc),
	5 mA
Guaranteed On	12 Vdc at 3 mA,
	20 Vac at 3 mA
Guaranteed Off	3 Vdc at 2 mA,
	2.5 Vac at 0.3 mA

IRIG-B:

Format	Amplitude Modulated
	IRIG-B122
Amplitude	1 to 10 Vpp
Impedance	10 kΩ
Ratio	3:1 to 6:1

I/O Module Interface (OPI, RTD and DIF):

Module Supply ⁽¹⁾	24 Vdc, 400 mA maximum
Configuration	RS-485, 2-wire multi-drop
Bus Length	1.2 km (4,000') maximum
Cable	Belden 3124A or equivalent

Standard Network Communications:

Configuration	RS-485, 2-wire multi-drop
Baud Rate	1.2, 2.4, 4.8, 9.6, 19.2 kbit/s
Protocols	Modbus RTU and A-B DF1
Isolation	120 Vac
Bus Length	1.2 km (4,000') maximum

Real-Time Clock and Non-Volatile RAM:

Power-Off Retention	7 Years at 20°C (68°F)
Battery Shelf Life	> 50 Years at 20°C (68°F)

Tightening Torque:

Ordering Option	MPS-CTU-XX-00
All Terminals	0.6 N·m (5.31 lbf·in) maximum
Ordering Option	MPS-CTU-XX-01
CT Input Terminals	0.79 N·m (7.0 lbf·in) maximum
All Other Terminals	0.6 N·m (5.31 lbf·in) maximum

Dimensions:

Height	121 mm (4.8")
Width	190 mm (7.5")
Depth	127 mm (5.0")

Shipping Weight2.0 kg (4.4 lb)

PWB Conformal CoatingMIL-1-46058 qualified
UL QMJU2 recognized

Environment:

Operating Temperature	-40 to 60°C (-40 to 140°F)
Storage Temperature	-55 to 80°C (-67 to 176°F)
Humidity	85% Non-Condensing

Surge WithstandANSI/IEEE C37.90.1-1989
(Oscillatory and Fast Transient)

CertificationCSA, Canada and USA



UL Recognized⁽¹⁰⁾



Australia



To:

CSA C22.2 No. 14 Industrial Control Equipment
UL 60947-4-1 Low-voltage switchgear and control gear - Part 4-1: Contactors and motor-starters - Electromechanical Contactors and motor-starters.
UL 1053 Ground Fault Sensing and Relaying Equipment
Australia, Regulatory Compliance Mark (RCM)

9.2 OPERATOR INTERFACE (MPS-OPI)

Supply ⁽¹⁾	24 Vdc Nominal (20 to 30 Vdc), 80 mA
Display Type	4 x 20 Alphanumeric Vacuum Fluorescent
Interconnection Cable:	
Type	Belden® 3124A or equivalent
Maximum Length	1.2 km (4,000')
Supplied length	4 m (13')
Tightening Torque	0.6 N·m (5.31 lbf·in) maximum
Dimensions:	
Height	98 mm (3.9")
Width	192 mm (7.6")
Depth	113 mm (4.5")
Shipping Weight	0.6 kg (1.3 lb)
PWB Conformal Coating	MIL-1-46058 qualified UL QMJU2 recognized
Environment:	
Operating Temperature	-40 to 60°C (-40 to 140°F)
Storage Temperature	-55 to 80°C (-67 to 160°F)
Humidity	85% Non-Condensing
Surge Withstand	ANSI/IEEE C37.90.1-1989 (Oscillatory and Fast Transient)
Certification	CSA, Canada and USA



UL Recognized⁽¹⁰⁾



Australia



Hazardous-LocationClass I Zone 2 Ex nA II T6
Class I, Division 2, Groups A, B, C, D

To:

CSA C22.2 No. 14 Industrial Control Equipment
CSA C22.2 No. 213-M1987 – Non-Incendive Electrical Equipment for use in Class I, Division 2 Hazardous Locations
UL 60947-4-1 Low-voltage switchgear and control gear - Part 4-1: Contactors and motor-starters - Electromechanical Contactors and motor-starters.
UL 1053 Ground Fault Sensing and Relaying Equipment

Australia, Regulatory Compliance Mark (RCM)

9.3 RTD MODULE (MPS-RTD)

Supply ⁽¹⁾	16 to 32 Vdc, 90 mA
Configuration	8 inputs, 3-wire RTD
RTD Types	Pt100, Ni100, Ni120, Cu10
Measurement Range	-40 to 200°C (-40 to 392°F), with open and short detection
Sensor Current	2 mA
Lead Compensation	20 Ω maximum
Accuracy:	
Pt100, Ni100, Ni120 RTD	1°C
Cu10 RTD	3°C
Interconnection Cable:	
Type	Belden® 3124A or equivalent
Maximum Length	1.2 km (4,000')
Supplied length	4 m (13')
Tightening Torque	0.6 N·m (5.31 lbf·in) maximum
Dimensions:	
Height	87 mm (3.4")
Width	113 mm (4.4")
Depth	53 mm (2.1")
Shipping Weight	0.4 kg (0.9 lb)
PWB Conformal Coating	MIL-1-46058 qualified UL QMJU2 recognized
Environment:	
Operating Temperature	-40 to 60°C (-40 to 140°F)
Storage Temperature	-55 to 80°C (-67 to 160°F)
Humidity	85% Non-Condensing
Surge Withstand	ANSI/IEEE C37.90.1-1989 (Oscillatory and Fast Transient)

CertificationCSA, Canada and USA



UL Recognized⁽¹⁰⁾



Australia



Hazardous-LocationClass I Zone 2 Ex nA II
T6
Class I, Division 2,
Groups A, B, C, D

To:

CSA C22.2 No. 14 Industrial Control Equipment
UL 60947-4-1 Low-voltage switchgear and control gear - Part 4-1: Contactors and motor-starters - Electromechanical Contactors and motor-starters.
UL 1053 Ground Fault Sensing and Relaying Equipment
CSA E60079-15: 02 Electrical Apparatus for Explosive Gas Atmospheres
CSA C22.2 No. 213-M1987 – Non-Incendive Electrical Equipment for use in Class I, Division 2 Hazardous Locations
UL 60079-15 Electrical Apparatus for Explosive Gas Atmospheres
Australia, Regulatory Compliance Mark (RCM)

9.4 DIFFERENTIAL MODULE (MPS-DIF)

Supply⁽¹⁾16 to 32 Vdc, 90 mA

CT Inputs:

Thermal Withstand:

Continuous.....5 x CT Primary Rating (I_d)

1-Second.....80 x I_d

Burden0.01 Ω

Terminal-Block Ratings:

CT Inputs.....25 A, 500 Vac

10 AWG (4.0 mm²)

Tightening Torque.....0.6 N·m (5.31 lbf·in)
maximum

Differential-Current Measurement:

Metering Range15 x I_d

Protection Range80 x I_d

Metering Accuracy:

$I < I_d$2% I_d

$I > I_d$2% Reading

Timing Accuracy.....5%, minimum trip time,
Range is set point +20 ms
to set point +150 ms,
median 81 ms

Interconnection Cable:

Type.....Belden® 3124A or
equivalent

Maximum Length.....1.2 km (4,000')

Supplied length.....4 m (13')

Dimensions:

Height87 mm (3.4")

Width113 mm (4.4")

Depth53 mm (2.1")

Shipping Weight0.4 kg (0.9 lb)

PWB Conformal CoatingMIL-1-46058 qualified
UL-QMJU2 recognized

Environment:

Operating Temperature-40 to 60°C (-40 to 140°F)

Storage Temperature-55 to 80°C (-67 to 176°F)

Humidity85% Non-Condensing

Surge Withstand.....ANSI/IEEE C37.90.1-
1989 (Oscillatory and Fast
Transient)

NOTES:

- (1) The I/O module supply (terminal 56), PTC (terminal 54), AN OUT (terminal 40), and 24-Vdc source (terminal 42) are referenced to the same common.
- (2) Current Threshold (%) is defined in Section 3.2.1.2. Power readings are not displayed for currents below this threshold. To maintain specified accuracy, phase CT's should be selected with a primary rating between 100 and 300% of motor full-load current.
- (3) Transformer accuracy not included.
- (4) Voltage unbalance is not displayed for positive-sequence voltage levels below 20% of system voltage setting.
- (5) Direct connection for system-voltages up to 600 Vac line-to-line. UL certification requires the voltage-input fault current to be limited to 5 kA. Use Class CC fuses, 3/10 A, Littelfuse KLKR.300. A self-adhesive label stating this limitation is provided.
- (6) Common-mode voltage relative to CTU terminal 3.
- (7) Referenced to COM.
- (8) Also see Tables 5.1 and 5.2.
- (9) When direct connection is used.
- (10) A 600Y/347 or 480Y/277 system is required when the MPS direct-voltage connection is used.
- (11) UL has evaluated the MPS for use with 60°/ 75° C conductors.

10. WARRANTY

The MPS Motor Protection System is warranted to be free from defects in material and workmanship for a period ten years from the date of purchase.

Littelfuse Startco will (at Littelfuse Startco's option) repair, replace, or refund the original purchase price of an MPS-CTU, MPS-OPI, MPS-RTD, or MPS-DIF that is determined by Littelfuse Startco to be defective if it is returned to the Littelfuse Startco factory, freight prepaid, within the warranty period. This warranty does not apply to repairs required as a result of misuse, negligence, an accident, improper installation, tampering or insufficient care. Littelfuse Startco does not warrant products repaired or modified by non-Littelfuse Startco personnel.

This page intentionally left blank.

APPENDIX A
MPS-OPI MENU MAP

MAIN MENU

METERING

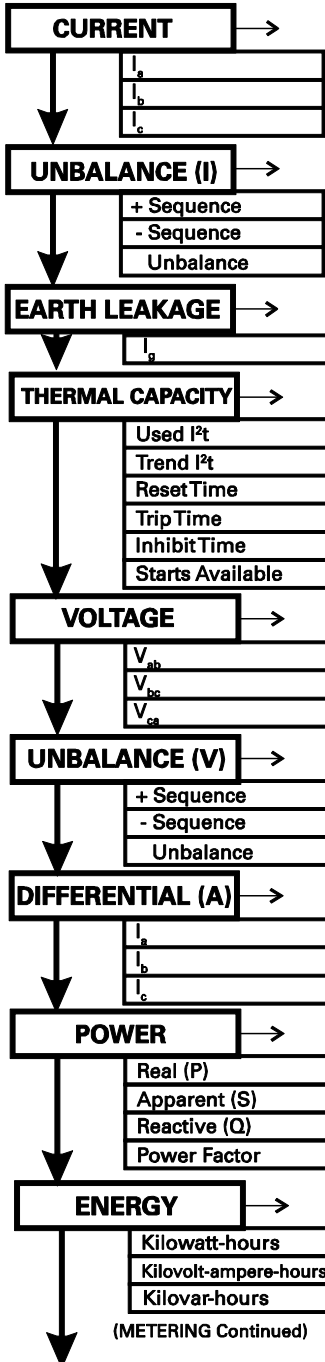

(METERING Continued)

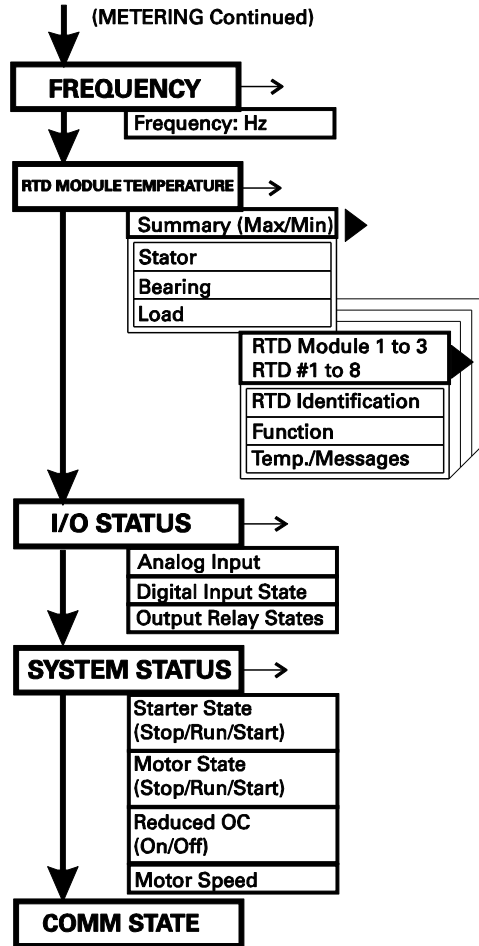

Notes:

- (1) List indicates possible trips and alarms.
- (2) Password required.
- (3) Lists do not match MPS-OPI menu order.
- (4) Password is required and the set point is locked when the motor is running.

Legend:

- [x] Enter numeric
- [s] Enter string
- [E/D] Enable/Disable
- [TA] Trip Action: Disable; Trip1; Trip2; Trip3
- [AA] Alarm Action: Disable; Alarm1; Alarm2; Alarm3
- [EA] Ethernet address

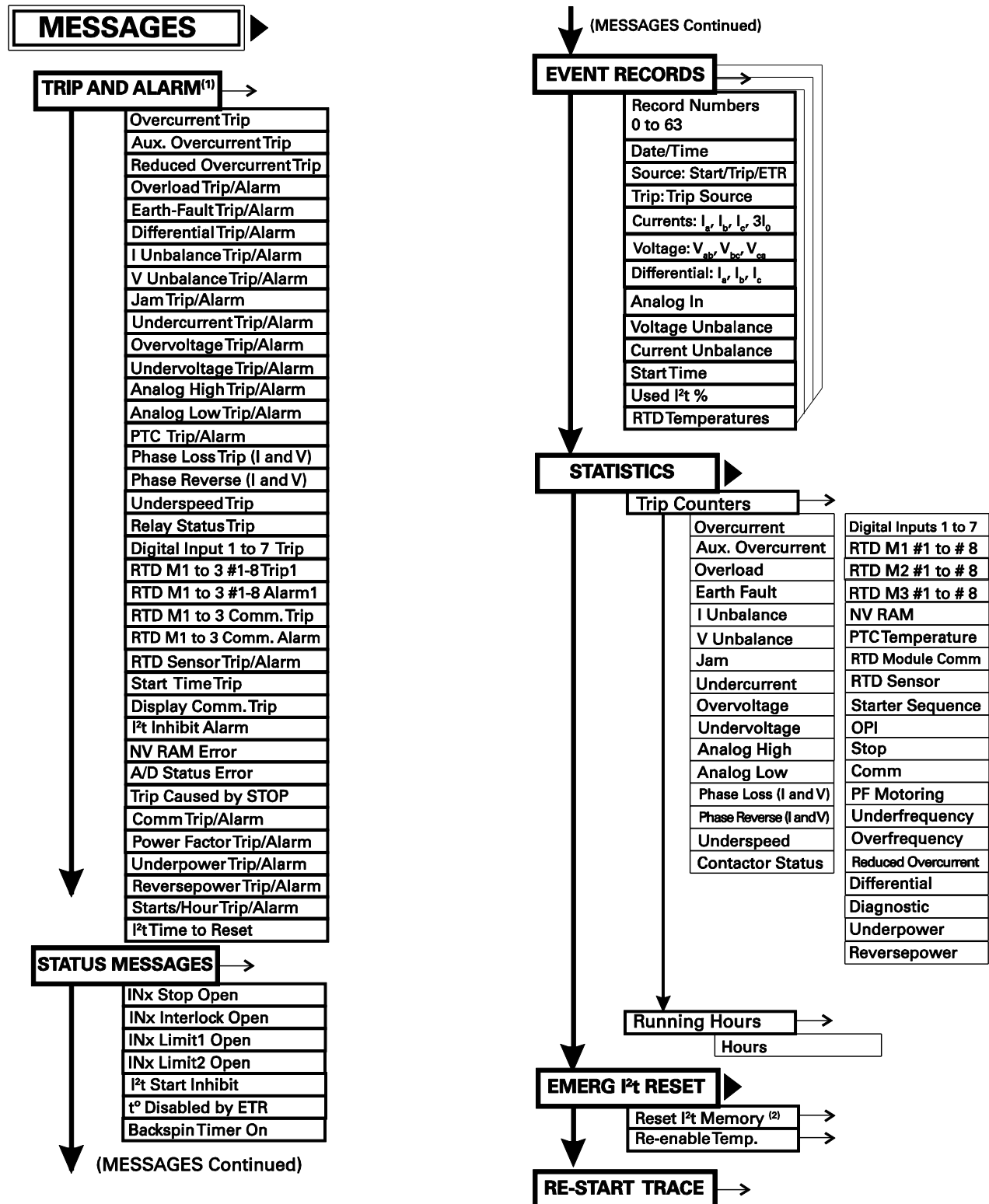

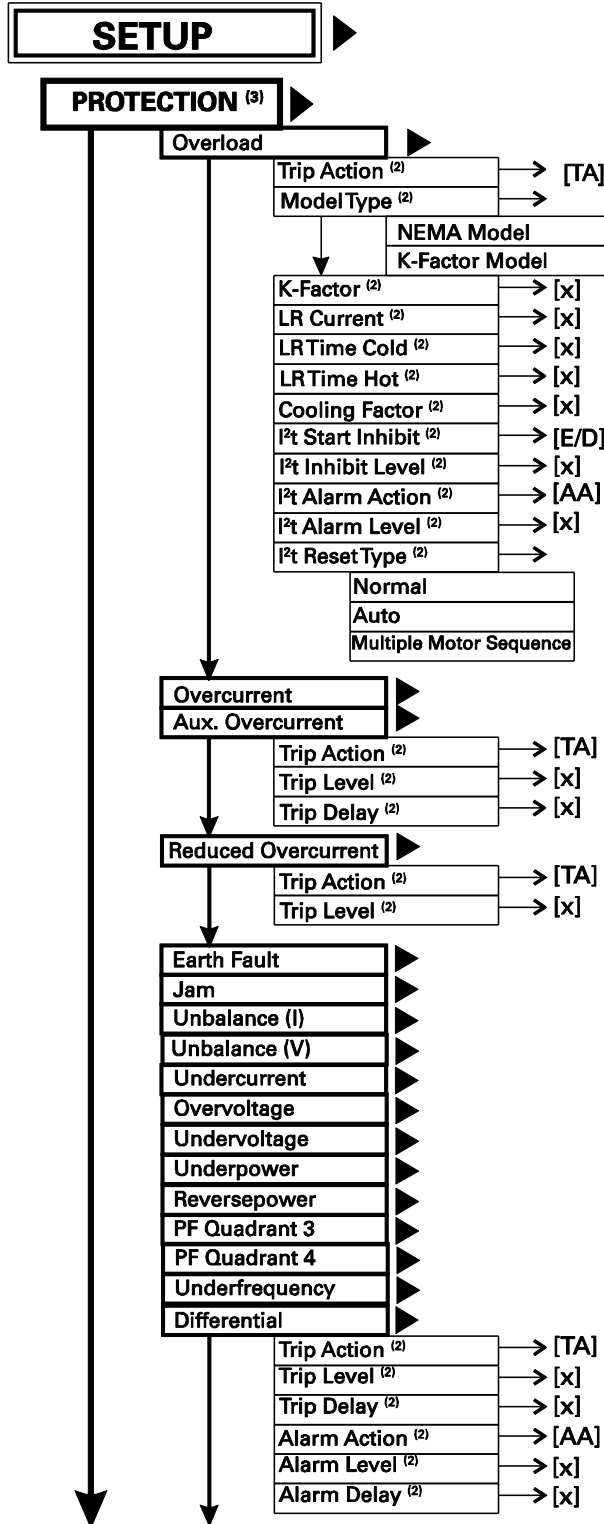

(SETUP Continued above)

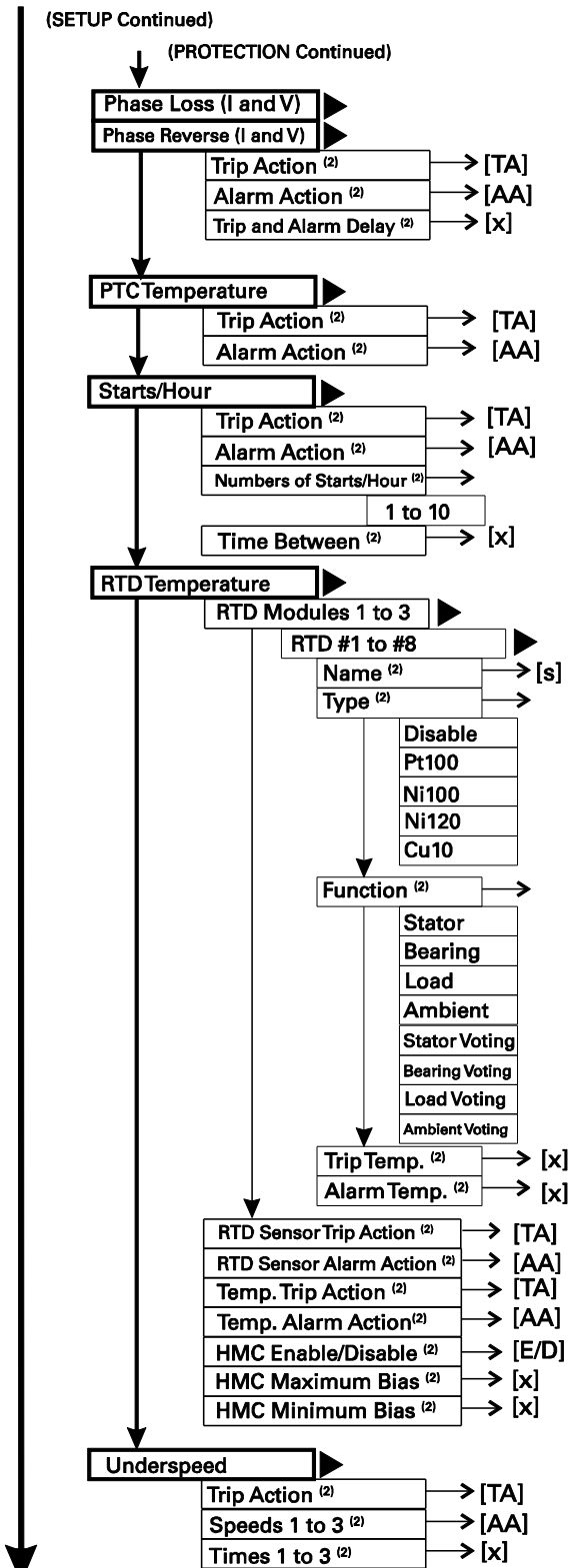

(SETUP Continued on next page)

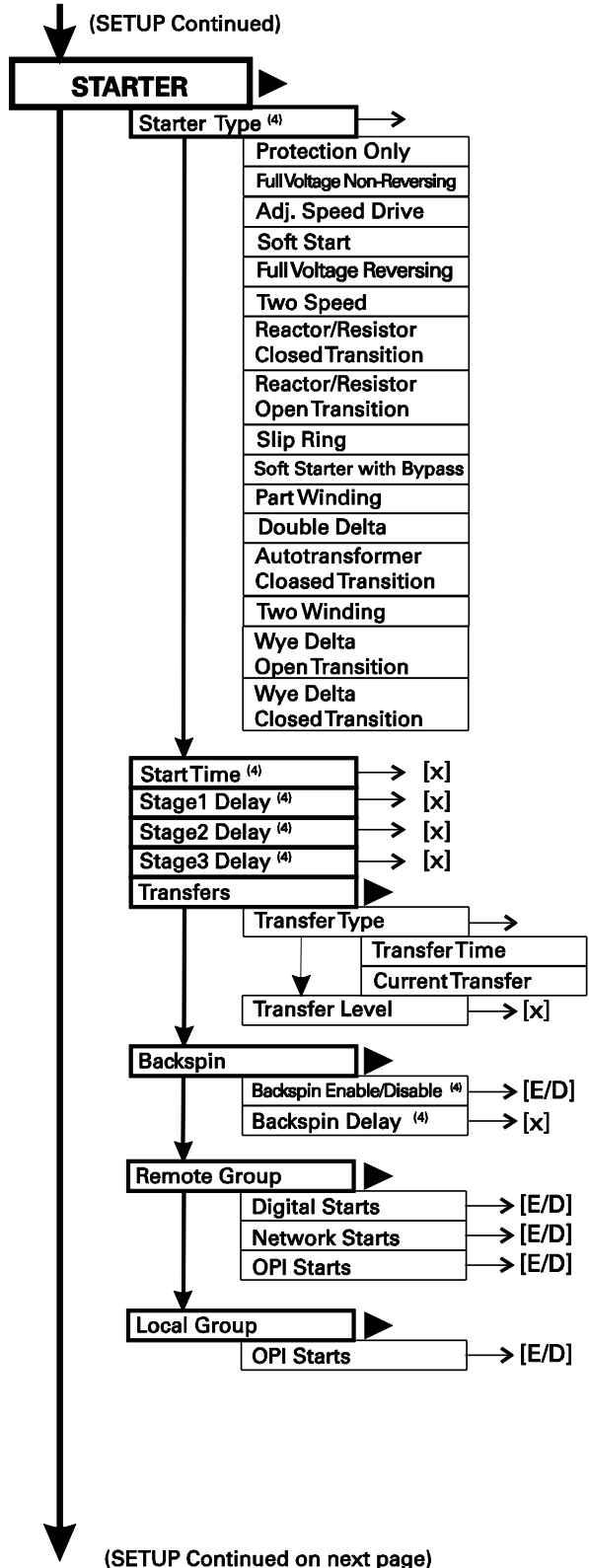
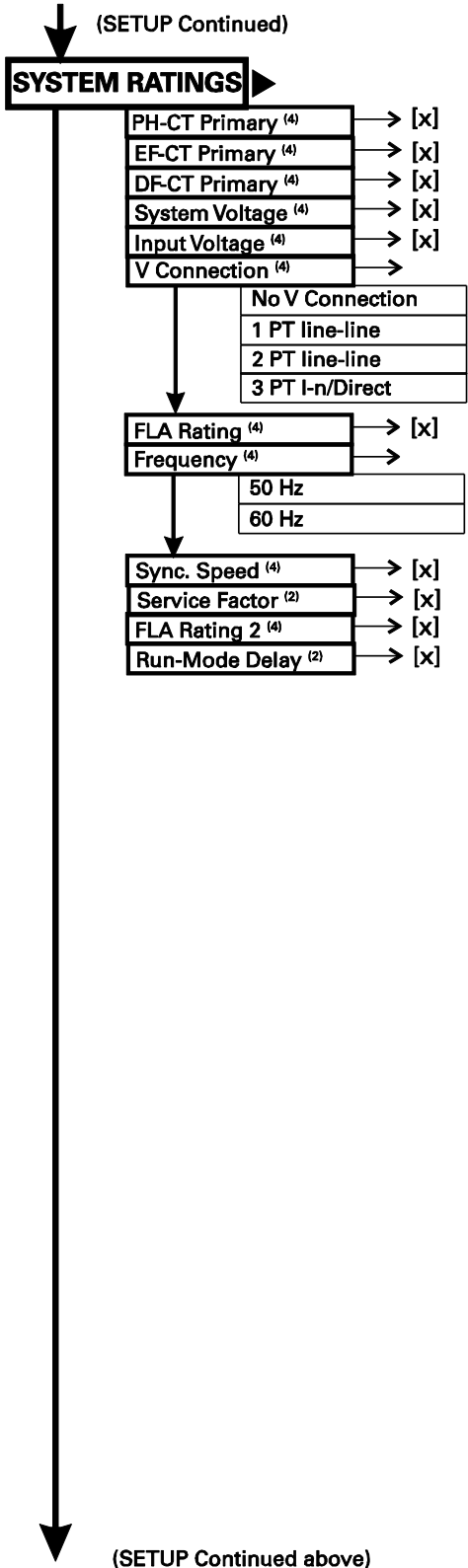

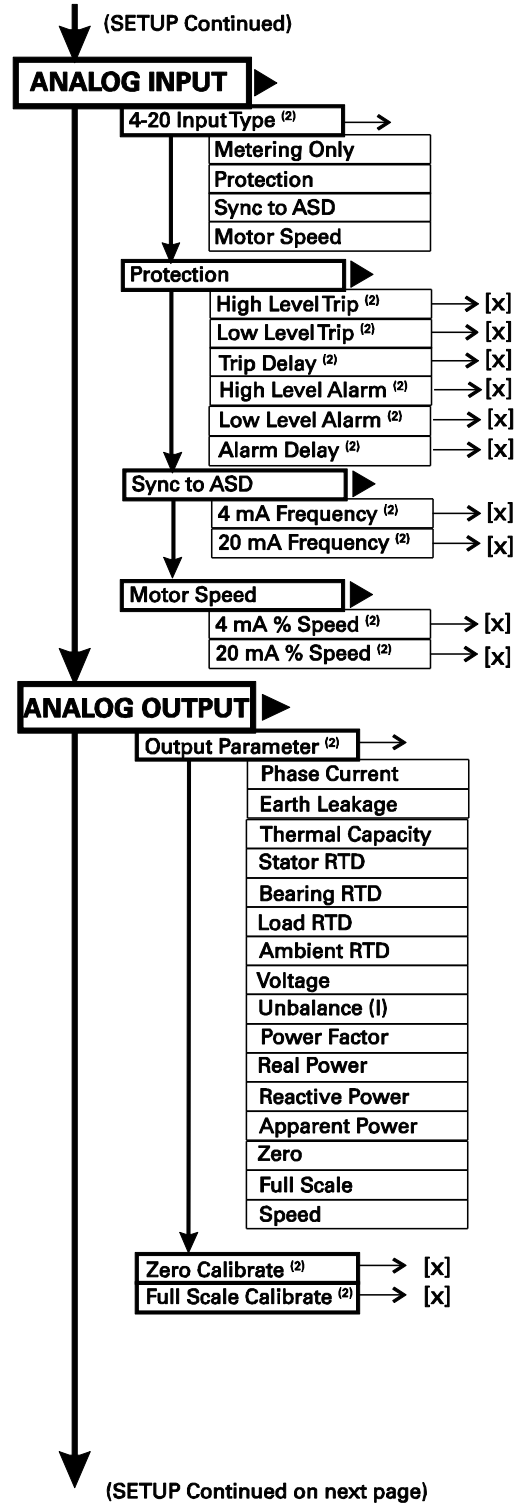
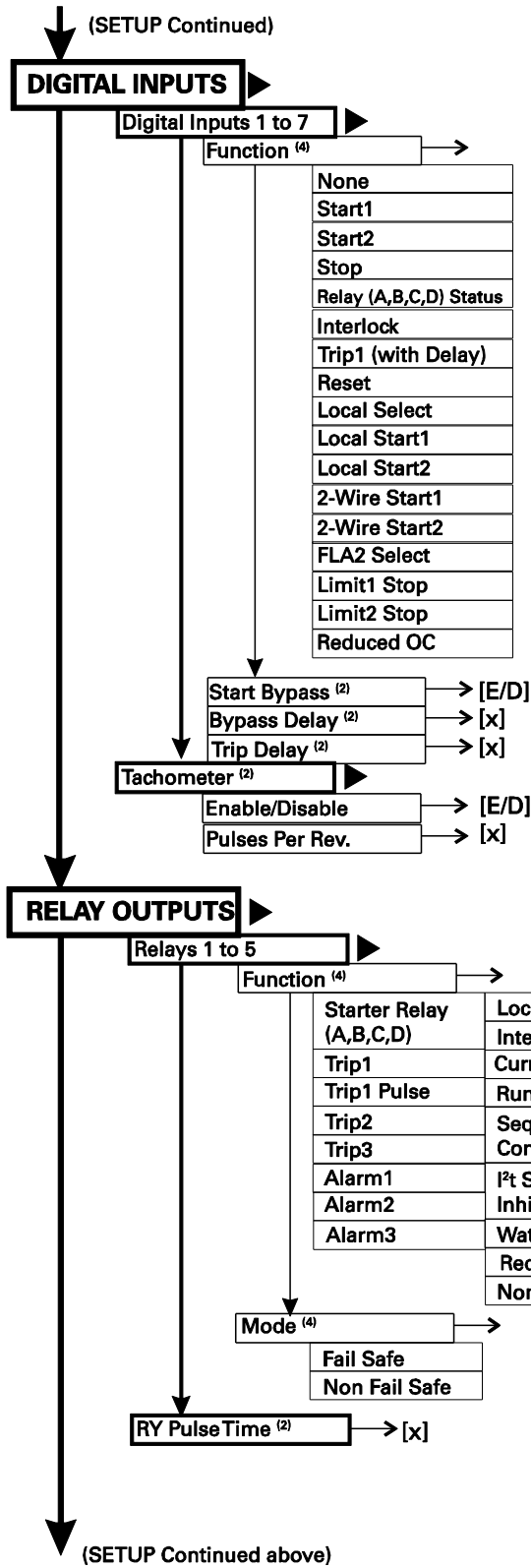

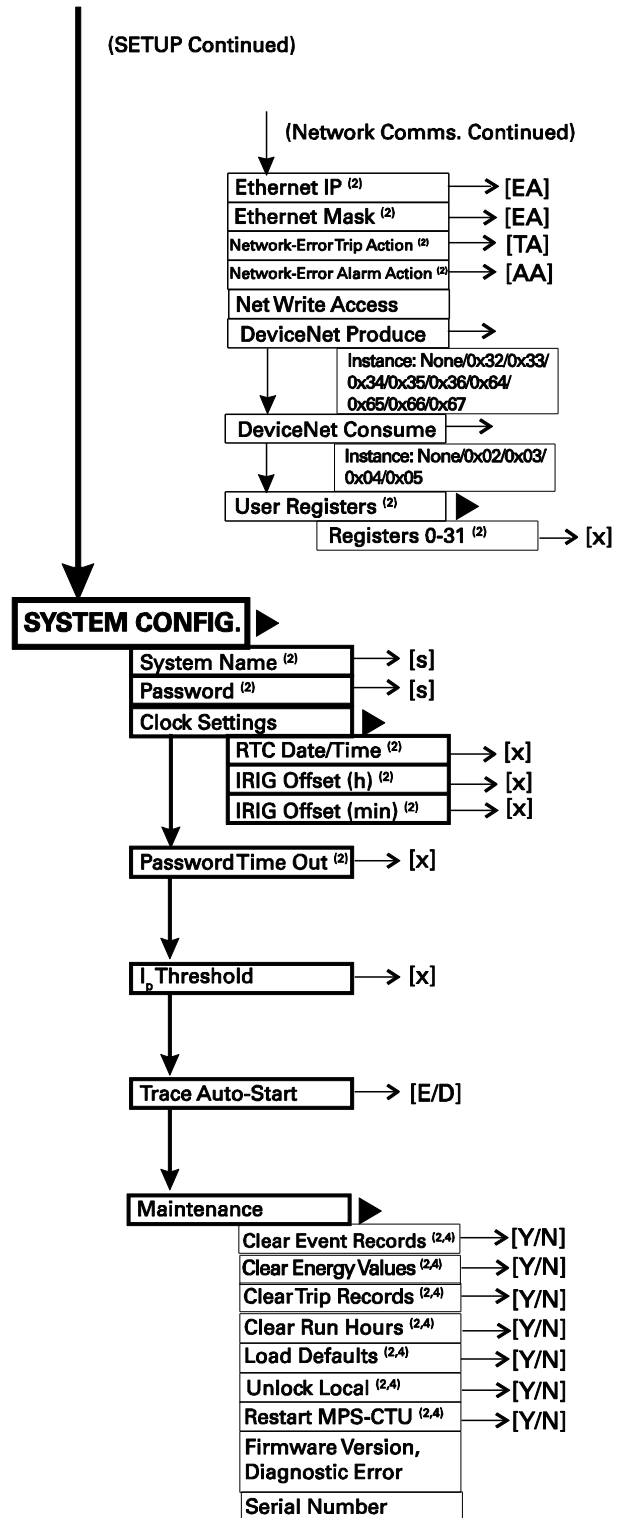
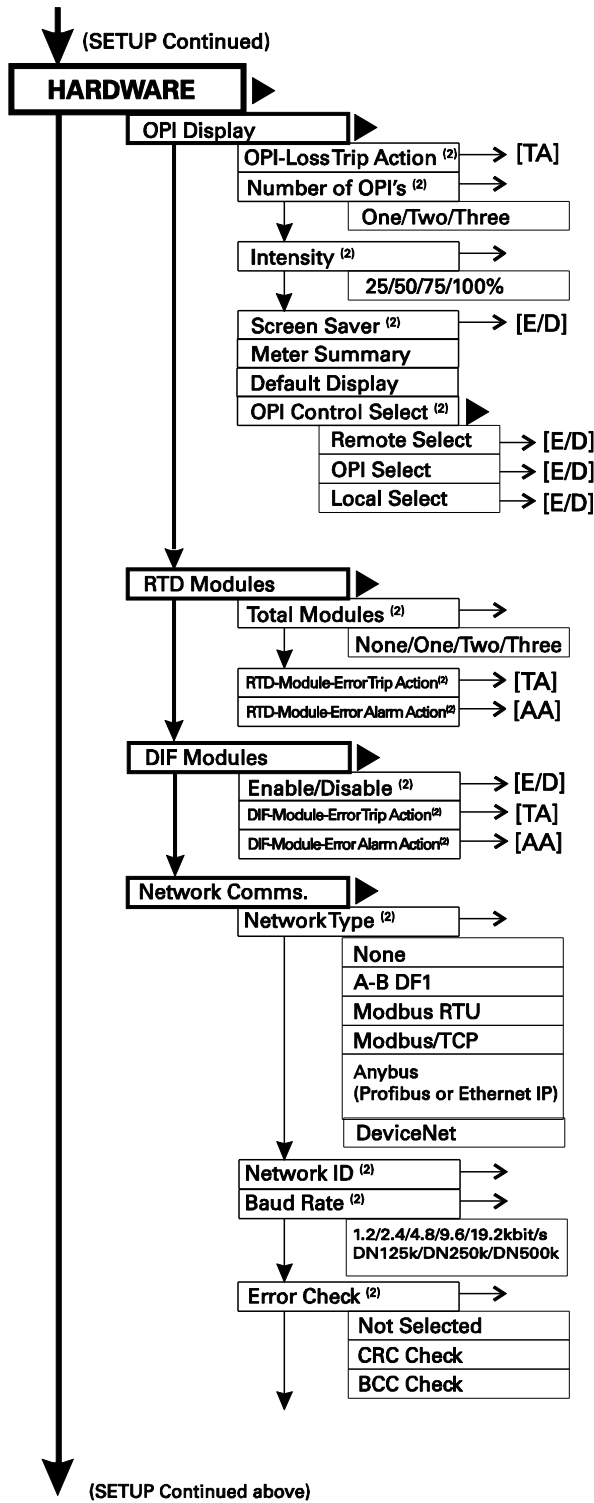

APPENDIX B
MPS SET-UP RECORD

Motor: _____ MPS S/N: _____ Date: _____

Firmware Revision: _____

PART I: SYSTEM AND MOTOR PARAMETERS

PARAMETER AND SETTINGS	MIN	DEFAULT	MAX	UNIT	PROGRAM SELECTION
System Ratings					
PH-CT Primary (I _p)	1	100.00	5,000	A	
EF-CT Primary (I _e)	1	5.00	5,000	A	
DF-CT Primary (I _d)	1	100.00	5,000	A	
System Voltage	0.12	0.60	25	kV	
Input Voltage	0.06	0.12	0.6	kV	
Input Voltage Connection		None			<input type="checkbox"/> None <input type="checkbox"/> 2PT <input type="checkbox"/> 1PT <input type="checkbox"/> 3PT/Direct
Full-Load Current	1	100.00	5,000	A	
Frequency		60		Hz	<input type="checkbox"/> 50 <input type="checkbox"/> 60
Synchronous Speed	10	1,800.00	10k	rpm	
Service Factor	1	1.00	1.25	pu	
FLA Rating 2	1	100.00	5,000	A	
Run-Mode Delay	5	10.00	120	s	
Digital Inputs	See Table 4.2 Input Function Definition				
Input 1: Function		Not Used			
Start Bypass		Disable			<input type="checkbox"/> Enable <input type="checkbox"/> Disable
Bypass Delay	0.5	5.00	100	s	
Trip Delay	0.01	0.10	100	s	
Input 2: Function		Not Used			
Start Bypass		Disable			<input type="checkbox"/> Enable <input type="checkbox"/> Disable
Bypass Delay	0.5	5.00	100	s	
Trip Delay	0.01	0.10	100	s	
Input 3: Function		Not Used			
Start Bypass		Disable			<input type="checkbox"/> Enable <input type="checkbox"/> Disable
Bypass Delay	0.5	5.00	100	s	
Trip Delay	0.01	0.10	100	s	
Input 4: Function		Not Used			
Start Bypass		Disable			<input type="checkbox"/> Enable <input type="checkbox"/> Disable
Bypass Delay	0.5	5.00	100	s	
Trip Delay	0.01	0.10	100	s	
Input 5: Function		Not Used			
Start Bypass		Disable			<input type="checkbox"/> Enable <input type="checkbox"/> Disable
Bypass Delay	0.5	5.00	100	s	
Trip Delay	0.01	0.10	100	s	
Input 6: Function		Not Used			
Start Bypass		Disable			<input type="checkbox"/> Enable <input type="checkbox"/> Disable
Bypass Delay	0.5	5.00	100	s	
Trip Delay	0.01	0.10	100	s	
Input 7: Function		Not Used			
Start Bypass		Disable			<input type="checkbox"/> Enable <input type="checkbox"/> Disable
Bypass Delay	0.5	5.00	100	s	
Trip Delay	0.01	0.10	100	s	

PARAMETER AND SETTINGS	MIN	DEFAULT	MAX	UNIT	PROGRAM SELECTION	
Tachometer		Disable			<input type="checkbox"/> Enable	<input type="checkbox"/> Disable
Pulses per Revolution	1	60.00	100			
Relay Outputs	See Table 4.1 Output Function Definition					
Relay 1: Function		None				
Mode		Fail-Safe			<input type="checkbox"/> Fail-Safe	<input type="checkbox"/> Non-Fail-Safe
Relay 2: Function		None				
Mode		Fail-Safe			<input type="checkbox"/> Fail-Safe	<input type="checkbox"/> Non-Fail-Safe
Relay 3: Function		None				
Mode		Fail-Safe			<input type="checkbox"/> Fail-Safe	<input type="checkbox"/> Non-Fail-Safe
Relay 4: Function		None				
Mode		Fail-Safe			<input type="checkbox"/> Fail-Safe	<input type="checkbox"/> Non-Fail-Safe
Relay 5: Function		None				
Mode		Fail-Safe			<input type="checkbox"/> Fail-Safe	<input type="checkbox"/> Non-Fail-Safe
RY Pulse Time	0.05	0.25	10	s		
Analog Input						
4-20 Input Type		Metering Only			<input type="checkbox"/> Metering Only <input type="checkbox"/> Protection	<input type="checkbox"/> Sync. to ASD <input type="checkbox"/> Motor Speed
Protection:						
High-Level Trip	0.1	16.00	20	mA		
Low-Level Trip	0.1	7.00	20	mA		
Trip Delay	0.01	5.00	100	s		
High-Level Alarm	0.1	14.00	20	mA		
Low-Level Alarm	0.1	9.00	20	mA		
Alarm Delay	0.01	1.00	100	s		
Sync to ASD Set Points:						
4-mA Frequency	0	10.00	70	Hz		
20-mA Frequency	0	60.00	70	Hz		
Motor Speed Set Points:						
4-mA Percent Speed	0	10.00	100	%		
20-mA Percent Speed	0	100.00	100	%		
Analog Output						
Output Parameter		Phase Current			See Table 4.3 Analog Output Parameter Definition	
Zero Calibrate	Factory Calibrated					
Full-Scale Calibrate	Factory Calibrated					
OPI Display						
OPI-Loss Trip		Trip1			<input type="checkbox"/> Disable <input type="checkbox"/> Trip2	<input type="checkbox"/> Trip1 <input type="checkbox"/> Trip3
Number of OPI's		1			<input type="checkbox"/> 1 <input type="checkbox"/> 2	<input type="checkbox"/> 3
Intensity		100		%	<input type="checkbox"/> 25 <input type="checkbox"/> 50	<input type="checkbox"/> 75 <input type="checkbox"/> 100
Screen Saver		Enable			<input type="checkbox"/> Enable	<input type="checkbox"/> Disable
OPI Control Select						
Remote Select		Enable			<input type="checkbox"/> Enable	<input type="checkbox"/> Disable
OPI Select		Enable			<input type="checkbox"/> Enable	<input type="checkbox"/> Disable
Local Select		Enable			<input type="checkbox"/> Enable	<input type="checkbox"/> Disable
RTD Modules						
Total Modules		0			<input type="checkbox"/> 0 <input type="checkbox"/> 1	<input type="checkbox"/> 2 <input type="checkbox"/> 3
RTD-Module-Error Trip Action		Disable			<input type="checkbox"/> Disable <input type="checkbox"/> Trip2	<input type="checkbox"/> Trip1 <input type="checkbox"/> Trip3

PARAMETER AND SETTINGS	MIN	DEFAULT	MAX	UNIT	PROGRAM SELECTION	
RTD-Module-Error Alarm Action		Disable			<input type="checkbox"/> Disable <input type="checkbox"/> Alarm2	<input type="checkbox"/> Alarm1 <input type="checkbox"/> Alarm3
Temperature Trip Action		Trip1			<input type="checkbox"/> Disable <input type="checkbox"/> Trip2	<input type="checkbox"/> Trip1 <input type="checkbox"/> Trip3
Temperature Alarm Action		Alarm1			<input type="checkbox"/> Disable <input type="checkbox"/> Alarm2	<input type="checkbox"/> Alarm1 <input type="checkbox"/> Alarm3
DIF Module						
Enable/Disable		Disable			<input type="checkbox"/> Enable	<input type="checkbox"/> Disable
DIF-Module-Error Trip Action		Disable			<input type="checkbox"/> Disable <input type="checkbox"/> Trip2	<input type="checkbox"/> Trip1 <input type="checkbox"/> Trip3
DIF-Module-Error Alarm Action		Disable			<input type="checkbox"/> Disable <input type="checkbox"/> Trip2	<input type="checkbox"/> Trip1 <input type="checkbox"/> Trip3
Network Communications						
Network Type		Modbus			<input type="checkbox"/> None <input type="checkbox"/> Allen-Bradley <input type="checkbox"/> Modbus	<input type="checkbox"/> DeviceNet <input type="checkbox"/> Anybus <input type="checkbox"/> Modbus TCP
Network ID	0	254	255			
Baud Rate		SCI 9600			<input type="checkbox"/> SCI 1200 <input type="checkbox"/> SCI 2400 <input type="checkbox"/> SCI 4800 <input type="checkbox"/> SCI 9600 <input type="checkbox"/> SCI 19200 ⁽¹⁾	<input type="checkbox"/> DN125 <input type="checkbox"/> DN250 <input type="checkbox"/> DN500
Error Checking		Not Selected			<input type="checkbox"/> Not Selected <input type="checkbox"/> CRC	<input type="checkbox"/> BCC
Ethernet IP		192.168.000.001				
Ethernet Mask		255.255.255.000				
Default Gateway		0.0.0.0				
Network-Error Trip Action		Disable			<input type="checkbox"/> Disable <input type="checkbox"/> Trip2	<input type="checkbox"/> Trip1 <input type="checkbox"/> Trip3
Network-Error Alarm Action		Disable			<input type="checkbox"/> Disable <input type="checkbox"/> Alarm2	<input type="checkbox"/> Alarm1 <input type="checkbox"/> Alarm3
DeviceNet Producing Assembly		0x36			<input type="checkbox"/> None <input type="checkbox"/> 0x33 <input type="checkbox"/> 0x35 <input type="checkbox"/> 0x64 <input type="checkbox"/> 0x66	<input type="checkbox"/> 0x32 <input type="checkbox"/> 0x34 <input type="checkbox"/> 0x36 <input type="checkbox"/> 0x65 <input type="checkbox"/> 0x67
DeviceNet Consuming Assembly		None			<input type="checkbox"/> None <input type="checkbox"/> 0x03 <input type="checkbox"/> 0x05	<input type="checkbox"/> 0x02 <input type="checkbox"/> 0x04
System Name	Startco MPS					
Change Password		1111				
Password Timeout	1	10.00	60	min.		
I_p Threshold (I_p is Phase-CT-Primary Rating)	0.10	0.10	0.50	x I _p		
Firmware Revision	See <i>Protection</i> <i>System Config</i> <i>Maintenance</i> <i>Firmware Version</i>					
Trace Auto-Start		Disable			<input type="checkbox"/> Enable	<input type="checkbox"/> Disable

⁽¹⁾ Error rate is 1 byte/120 kB. For high reliability, use SCI9600.

PART II: STARTER PARAMETERS

SET POINT	MIN	DEFAULT	MAX	UNIT	PROGRAM SELECTION	
Starter Type (see Table 6.2)	Protection Only					
Start Time	0.1	20.00	500	s		
Stage 1 Delay	0.1	20.00	500	s		
Stage 2 Delay	0.1	20.00	500	s		
Stage 3 Delay	0.1	20.00	500	s		
Backspin Timer		Disable			<input type="checkbox"/> Enable	<input type="checkbox"/> Disable
Backspin Delay	0.1	5.00	3,600	s		
Remote Group						
Digital Inputs		Enable			<input type="checkbox"/> Enable	<input type="checkbox"/> Disable
Network		Enable			<input type="checkbox"/> Enable	<input type="checkbox"/> Disable
OPI		Enable			<input type="checkbox"/> Enable	<input type="checkbox"/> Disable
Transfer						
Type		Time			<input type="checkbox"/> Time	<input type="checkbox"/> Current
Level	1.0	1.25	3.0	x FLA		

PART III: PROTECTION SET POINTS

FUNCTION & SET POINT	MIN	DEFAULT	MAX	UNIT	PROGRAM SELECTION	
Overload						
Trip Action		Trip1			<input type="checkbox"/> Disable <input type="checkbox"/> Trip2	<input type="checkbox"/> Trip1 <input type="checkbox"/> Trip3
Model Type		NEMA			<input type="checkbox"/> NEMA	<input type="checkbox"/> K-Factor
K-Factor	1	6.00	10			
Locked-Rotor Current	1.5	6.00	10	x FLA		
Locked-Rotor Time Cold	0.10	10.00	100	s		
Locked-Rotor Time Hot	0.10	5.00	100	s		
Cooling Factor	0.10	2.00	10			
I ² t Start Inhibit		Disable			<input type="checkbox"/> Enable	<input type="checkbox"/> Disable
I ² t Inhibit Level (Per Unit Based on 100% I ² t)	0.10	0.30	.90	pu		
I ² t Alarm Action		Alarm1			<input type="checkbox"/> Disable <input type="checkbox"/> Alarm2	<input type="checkbox"/> Alarm1 <input type="checkbox"/> Alarm3
I ² t Overload Alarm Level	0.50	1.00	1	pu		
Reset Type		Normal			<input type="checkbox"/> Normal <input type="checkbox"/> Multiple Motor Sequence	<input type="checkbox"/> Auto
Overcurrent						
Trip Action		Trip1			<input type="checkbox"/> Disable <input type="checkbox"/> Trip2	<input type="checkbox"/> Trip1 <input type="checkbox"/> Trip3
Trip Level (I _p is Phase-CT-Primary Rating)	1	10.00	15	x I _p		
Trip Delay	0	0.05	10	s		
Auxiliary Overcurrent						
Trip Action		Disable			<input type="checkbox"/> Disable <input type="checkbox"/> Trip2	<input type="checkbox"/> Trip1 <input type="checkbox"/> Trip3
Trip Level (I _p is Phase-CT-Primary Rating)	1	10.00	15	x I _p		
Trip Delay	0	0.05	10	s		

FUNCTION & SET POINT	MIN	DEFAULT	MAX	UNIT	PROGRAM SELECTION	
Reduced Overcurrent						
Trip Action		Trip1			<input type="checkbox"/> Disable <input type="checkbox"/> Trip2	<input type="checkbox"/> Trip1 <input type="checkbox"/> Trip3
Trip Level (I_p is Phase-CT-Primary Rating)	1	2.00	15	$x I_p$		
Earth Fault						
Trip Action		Trip1			<input type="checkbox"/> Disable <input type="checkbox"/> Trip2	<input type="checkbox"/> Trip1 <input type="checkbox"/> Trip3
Trip Level (I_e is EF-CT-Primary Rating)	0.05	0.40	1	$x I_e$		
Trip Delay	0	0.25	100	s		
Alarm Action		Alarm1			<input type="checkbox"/> Disable <input type="checkbox"/> Alarm2	<input type="checkbox"/> Alarm1 <input type="checkbox"/> Alarm3
Alarm Level (I_e is EF-CT-Primary Rating)	0.05	0.20	1	$x I_e$		
Alarm Delay	0	1.00	100	s		
Jam						
Trip Action		Trip1			<input type="checkbox"/> Disable <input type="checkbox"/> Trip2	<input type="checkbox"/> Trip1 <input type="checkbox"/> Trip3
Trip Level	1	6.00	10	$x FLA$		
Trip Delay	1	5.00	100	s		
Alarm Action		Alarm1			<input type="checkbox"/> Disable <input type="checkbox"/> Alarm2	<input type="checkbox"/> Alarm1 <input type="checkbox"/> Alarm3
Alarm Level	1	3.00	10	$x FLA$		
Alarm Delay	1	5.00	100	s		
Unbalance (I)						
Trip Action		Trip1			<input type="checkbox"/> Disable <input type="checkbox"/> Trip2	<input type="checkbox"/> Trip1 <input type="checkbox"/> Trip3
Trip Level (Per Unit Based on I_2/I_1)	0.05	0.25	1	pu		
Trip Delay	1	15.00	100	s		
Alarm Action		Alarm1			<input type="checkbox"/> Disable <input type="checkbox"/> Alarm2	<input type="checkbox"/> Alarm1 <input type="checkbox"/> Alarm3
Alarm Level	0.05	0.10	1	pu		
Alarm Delay	1	10.00	100	s		
Phase Loss (I)						
Trip Action		Trip1			<input type="checkbox"/> Disable <input type="checkbox"/> Trip2	<input type="checkbox"/> Trip1 <input type="checkbox"/> Trip3
Phase Loss Delay	1	5.00	100	s		
Phase Reverse (I)						
Trip Action		Disable			<input type="checkbox"/> Disable <input type="checkbox"/> Trip2	<input type="checkbox"/> Trip1 <input type="checkbox"/> Trip3
Alarm Action		Alarm1			<input type="checkbox"/> Disable <input type="checkbox"/> Alarm2	<input type="checkbox"/> Alarm1 <input type="checkbox"/> Alarm3
Trip and Alarm Delay	1	2.00	100	s		

FUNCTION & SET POINT	MIN	DEFAULT	MAX	UNIT	PROGRAM SELECTION	
Unbalance (V)						
Trip Action		Trip1			<input type="checkbox"/> Disable <input type="checkbox"/> Trip2	<input type="checkbox"/> Trip1 <input type="checkbox"/> Trip3
Trip Level (Per Unit Based on V_2/V_1)	0.05	0.10	1	pu		
Trip Delay	1	15.00	100	s		
Alarm Action		Alarm1			<input type="checkbox"/> Disable <input type="checkbox"/> Alarm2	<input type="checkbox"/> Alarm1 <input type="checkbox"/> Alarm3
Alarm Level	0.05	0.05	1	pu		
Alarm Delay	1	10.00	100	s		
Phase Loss (V)						
Trip Action		Disable			<input type="checkbox"/> Disable <input type="checkbox"/> Trip2	<input type="checkbox"/> Trip1 <input type="checkbox"/> Trip3
Phase Loss Delay	1	5.00	100	s		
Phase Reverse (V)						
Trip Action		Disable			<input type="checkbox"/> Disable <input type="checkbox"/> Trip2	<input type="checkbox"/> Trip1 <input type="checkbox"/> Trip3
Alarm Action		Alarm1			<input type="checkbox"/> Disable <input type="checkbox"/> Alarm2	<input type="checkbox"/> Alarm1 <input type="checkbox"/> Alarm3
Phase Reverse Trip and Alarm Delay	1	2.00	100	s		
Undercurrent						
Trip Action		Disable			<input type="checkbox"/> Disable <input type="checkbox"/> Trip2	<input type="checkbox"/> Trip1 <input type="checkbox"/> Trip3
Trip Level	0.1	0.50	1	x FLA		
Trip Delay	1	10.00	100	s		
Alarm Action		Disable			<input type="checkbox"/> Disable <input type="checkbox"/> Alarm2	<input type="checkbox"/> Alarm1 <input type="checkbox"/> Alarm3
Alarm Level	0.1	0.80	1	x FLA		
Alarm Delay	1	20.00	100	s		
Differential						
Trip Action		Disable			<input type="checkbox"/> Disable <input type="checkbox"/> Trip2	<input type="checkbox"/> Trip1 <input type="checkbox"/> Trip3
Trip Level (I_d is DF-CT-Primary Current)	0.1	1.00	15	x I_d		
Trip Delay	0	0.10	10	s		
Alarm Action		Disable			<input type="checkbox"/> Disable <input type="checkbox"/> Alarm2	<input type="checkbox"/> Alarm1 <input type="checkbox"/> Alarm3
Alarm Level (I_d is DF-CT-Primary Current)	0.1	0.50	15	x I_d		
Alarm Delay	0	0.10	10	s		
PF Quadrant 4						
Trip Action		Disable			<input type="checkbox"/> Disable <input type="checkbox"/> Trip2	<input type="checkbox"/> Trip1 <input type="checkbox"/> Trip3
Trip Level	0.5	0.80	1			
Trip Delay	0.1	5.00	500	s		
Alarm Action		Disable			<input type="checkbox"/> Disable <input type="checkbox"/> Alarm2	<input type="checkbox"/> Alarm1 <input type="checkbox"/> Alarm3
Alarm Level	0.5	0.90	1			
Alarm Delay	0.1	5.00	500	s		

FUNCTION & SET POINT	MIN	DEFAULT	MAX	UNIT	PROGRAM SELECTION	
PF Quadrant 3						
Trip Action		Disable			<input type="checkbox"/> Disable <input type="checkbox"/> Trip2	<input type="checkbox"/> Trip1 <input type="checkbox"/> Trip3
Trip Level	0.5	0.80	1			
Trip Delay	0.1	5.00	500	s		
Alarm Action		Disable			<input type="checkbox"/> Disable <input type="checkbox"/> Alarm2	<input type="checkbox"/> Alarm1 <input type="checkbox"/> Alarm3
Alarm Level	0.5	0.90	1			
Alarm Delay	0.1	5.00	500	s		
Underpower						
Trip Action		Disable			<input type="checkbox"/> Disable <input type="checkbox"/> Trip2	<input type="checkbox"/> Trip1 <input type="checkbox"/> Trip3
Trip Level (Per Unit of Rated Power)	0.1	0.80	1	pu		
Trip Delay	0.5	5.00	500	s		
Alarm Action		Disable			<input type="checkbox"/> Disable <input type="checkbox"/> Alarm2	<input type="checkbox"/> Alarm1 <input type="checkbox"/> Alarm3
Alarm Level (Per Unit of Rated Power)	0.1	0.80	1	pu		
Alarm Delay	0.5	1.00	500	s		
Reversepower						
Trip Action		Disable			<input type="checkbox"/> Disable <input type="checkbox"/> Trip2	<input type="checkbox"/> Trip1 <input type="checkbox"/> Trip3
Trip Level (Per Unit of Rated Power)	0.1	0.20	1	pu		
Trip Delay	0.5	5.00	500	s		
Alarm Action		Disable			<input type="checkbox"/> Disable <input type="checkbox"/> Alarm2	<input type="checkbox"/> Alarm1 <input type="checkbox"/> Alarm3
Alarm Level (Per Unit of Rated Power)	0.1	0.20	1	pu		
Alarm Delay	0.5	1.00	500	s		
Underfrequency						
Trip Action		Disable			<input type="checkbox"/> Disable <input type="checkbox"/> Trip2	<input type="checkbox"/> Trip1 <input type="checkbox"/> Trip3
Trip Level	30	45	80	Hz		
Trip Delay	0.5	5	500	s		
Alarm Action		Disable			<input type="checkbox"/> Disable <input type="checkbox"/> Alarm2	<input type="checkbox"/> Alarm1 <input type="checkbox"/> Alarm3
Alarm Level	30	48	80	Hz		
Alarm Delay	0.5	1	500	s		
Overfrequency						
Trip Action		Disable			<input type="checkbox"/> Disable <input type="checkbox"/> Trip2	<input type="checkbox"/> Trip1 <input type="checkbox"/> Trip3
Trip Level	30	65	80	Hz		
Trip Delay	0.5	5	500	s		
Alarm Action		Disable			<input type="checkbox"/> Disable <input type="checkbox"/> Alarm2	<input type="checkbox"/> Alarm1 <input type="checkbox"/> Alarm3
Alarm Level	30	62	80	Hz		
Alarm Delay	0.5	1	500	s		

FUNCTION & SET POINT	MIN	DEFAULT	MAX	UNIT	PROGRAM SELECTION	
PTC Temperature						
Trip Action		Disable			<input type="checkbox"/> Disable <input type="checkbox"/> Trip2	<input type="checkbox"/> Trip1 <input type="checkbox"/> Trip3
Alarm Action		Disable			<input type="checkbox"/> Disable <input type="checkbox"/> Alarm2	<input type="checkbox"/> Alarm1 <input type="checkbox"/> Alarm3
RTD-Sensor-Error Trip Action		Disable			<input type="checkbox"/> Disable <input type="checkbox"/> Trip2	<input type="checkbox"/> Trip1 <input type="checkbox"/> Trip3
RTD-Sensor-Error Alarm Action		Alarm1			<input type="checkbox"/> Disable <input type="checkbox"/> Alarm2	<input type="checkbox"/> Alarm1 <input type="checkbox"/> Alarm3
Hot-Motor Compensation (HMC)		Disable			<input type="checkbox"/> Enable	<input type="checkbox"/> Disable
HMC High	40	150.00	200	°C		
HMC Low	40	40.00	200	°C		
Acceleration Failure—Underspeed						
Trip Action		Disable			<input type="checkbox"/> Disable <input type="checkbox"/> Trip2	<input type="checkbox"/> Trip1 <input type="checkbox"/> Trip3
Speed 1 (Percent Sync Speed)	1	30.00	100	% SS		
Time 1	1	5.00	1,000	s		
Speed 2	1	60.00	100	% SS		
Time 2	1	10.00	1,000	s		
Speed 3	1	90.00	100	% SS		
Time 3	1	15.00	1,000	s		
Overvoltage						
Trip Action		Trip1			<input type="checkbox"/> Disable <input type="checkbox"/> Trip2	<input type="checkbox"/> Trip1 <input type="checkbox"/> Trip3
Trip Level (V _p is system voltage)	1	1.20	1.4	x V _p		
Trip Delay	1	5.00	500	s		
Alarm Action		Alarm1			<input type="checkbox"/> Disable <input type="checkbox"/> Alarm2	<input type="checkbox"/> Alarm1 <input type="checkbox"/> Alarm3
Alarm Level (V _p is system voltage)	1	1.10	1.4	x V _p		
Alarm Delay	1	5.00	500	s		
Undervoltage						
Trip Action		Disable			<input type="checkbox"/> Disable <input type="checkbox"/> Trip2	<input type="checkbox"/> Trip1 <input type="checkbox"/> Trip3
Trip Level (V _p is system voltage)	0.5	0.70	1	x V _p		
Trip Delay	1	5.00	500	s		
Alarm Action		Disable			<input type="checkbox"/> Disable <input type="checkbox"/> Alarm2	<input type="checkbox"/> Alarm1 <input type="checkbox"/> Alarm3
Alarm Level (V _p is system voltage)	0.5	0.80	1	x V _p		
Alarm Delay	1	5.00	500	s		
Starts/Hour						
Trip Action		Disable			<input type="checkbox"/> Disable <input type="checkbox"/> Trip2	<input type="checkbox"/> Trip1 <input type="checkbox"/> Trip3
Alarm Action					<input type="checkbox"/> Disable <input type="checkbox"/> Alarm2	<input type="checkbox"/> Alarm1 <input type="checkbox"/> Alarm3
Number of Starts/Hour	1	5	10			
Time Between Starts	0	0.00	500	min		

FUNCTION & SET POINT	MIN	DEFAULT	MAX	UNIT	PROGRAM SELECTION
RTD TEMPERATURE Requires RTD Module(s)					
RTD M1 #1:					
Name	RTD Module 1 #1				
Type		Disable			<input type="checkbox"/> Disable <input type="checkbox"/> Ni120 Ω <input type="checkbox"/> Pt100 Ω <input type="checkbox"/> Cu10 Ω <input type="checkbox"/> Ni100 Ω
Function		Stator			<input type="checkbox"/> Stator <input type="checkbox"/> Load <input type="checkbox"/> Bearing <input type="checkbox"/> Ambient <input type="checkbox"/> Stator Voting <input type="checkbox"/> Load Voting <input type="checkbox"/> Bearing Voting <input type="checkbox"/> Ambient Voting
Trip	40	130.00	200	°C	
Alarm	40	110.00	200	°C	
RTD M1 #2:					
Name	RTD Module 1 #2				
Type		Disable			<input type="checkbox"/> Disable <input type="checkbox"/> Ni120 Ω <input type="checkbox"/> Pt100 Ω <input type="checkbox"/> Cu10 Ω <input type="checkbox"/> Ni100 Ω
Function		Stator			<input type="checkbox"/> Stator <input type="checkbox"/> Load <input type="checkbox"/> Bearing <input type="checkbox"/> Ambient <input type="checkbox"/> Stator Voting <input type="checkbox"/> Load Voting <input type="checkbox"/> Bearing Voting <input type="checkbox"/> Ambient Voting
Trip	40	130.00	200	°C	
Alarm	40	110.00	200	°C	
RTD M1 #3:					
Name	RTD Module 1 #3				
Type		Disable			<input type="checkbox"/> Disable <input type="checkbox"/> Ni120 Ω <input type="checkbox"/> Pt100 Ω <input type="checkbox"/> Cu10 Ω <input type="checkbox"/> Ni100 Ω
Function		Stator			<input type="checkbox"/> Stator <input type="checkbox"/> Load <input type="checkbox"/> Bearing <input type="checkbox"/> Ambient <input type="checkbox"/> Stator Voting <input type="checkbox"/> Load Voting <input type="checkbox"/> Bearing Voting <input type="checkbox"/> Ambient Voting
Trip	40	130.00	200	°C	
Alarm	40	110.00	200	°C	
RTD M1 #4:					
Name	RTD Module 1 #4				
Type		Disable			<input type="checkbox"/> Disable <input type="checkbox"/> Ni120 Ω <input type="checkbox"/> Pt100 Ω <input type="checkbox"/> Cu10 Ω <input type="checkbox"/> Ni100 Ω
Function		Stator			<input type="checkbox"/> Stator <input type="checkbox"/> Load <input type="checkbox"/> Bearing <input type="checkbox"/> Ambient <input type="checkbox"/> Stator Voting <input type="checkbox"/> Load Voting <input type="checkbox"/> Bearing Voting <input type="checkbox"/> Ambient Voting
Trip	40	130.00	200	°C	
Alarm	40	110.00	200	°C	

FUNCTION & SET POINT	MIN	DEFAULT	MAX	UNIT	PROGRAM SELECTION
RTD M1 #5:					
Name	RTD Module 1 #5				
Type		Disable			<input type="checkbox"/> Disable <input type="checkbox"/> Ni120 Ω <input type="checkbox"/> Pt100 Ω <input type="checkbox"/> Cu10 Ω <input type="checkbox"/> Ni100 Ω
Function		Stator			<input type="checkbox"/> Stator <input type="checkbox"/> Load <input type="checkbox"/> Bearing <input type="checkbox"/> Ambient <input type="checkbox"/> Stator Voting <input type="checkbox"/> Load Voting <input type="checkbox"/> Bearing Voting <input type="checkbox"/> Ambient Voting
Trip	40	130.00	200	°C	
Alarm	40	110.00	200	°C	
RTD M1 #6:					
Name	RTD Module 1 #6				
Type		Disable			<input type="checkbox"/> Disable <input type="checkbox"/> Ni120 Ω <input type="checkbox"/> Pt100 Ω <input type="checkbox"/> Cu10 Ω <input type="checkbox"/> Ni100 Ω
Function		Stator			<input type="checkbox"/> Stator <input type="checkbox"/> Load <input type="checkbox"/> Bearing <input type="checkbox"/> Ambient <input type="checkbox"/> Stator Voting <input type="checkbox"/> Load Voting <input type="checkbox"/> Bearing Voting <input type="checkbox"/> Ambient Voting
Trip	40	130.00	200	°C	
Alarm	40	110.00	200	°C	
RTD M1 #7:					
Name	RTD Module 1 #7				
Type		Disable			<input type="checkbox"/> Disable <input type="checkbox"/> Ni120 Ω <input type="checkbox"/> Pt100 Ω <input type="checkbox"/> Cu10 Ω <input type="checkbox"/> Ni100 Ω
Function		Stator			<input type="checkbox"/> Stator <input type="checkbox"/> Load <input type="checkbox"/> Bearing <input type="checkbox"/> Ambient <input type="checkbox"/> Stator Voting <input type="checkbox"/> Load Voting <input type="checkbox"/> Bearing Voting <input type="checkbox"/> Ambient Voting
Trip	40	130.00	200	°C	
Alarm	40	110.00	200	°C	
RTD M1 #8:					
Name	RTD Module 1 #8				
Type		Disable			<input type="checkbox"/> Disable <input type="checkbox"/> Ni120 Ω <input type="checkbox"/> Pt100 Ω <input type="checkbox"/> Cu10 Ω <input type="checkbox"/> Ni100 Ω
Function		Stator			<input type="checkbox"/> Stator <input type="checkbox"/> Load <input type="checkbox"/> Bearing <input type="checkbox"/> Ambient <input type="checkbox"/> Stator Voting <input type="checkbox"/> Load Voting <input type="checkbox"/> Bearing Voting <input type="checkbox"/> Ambient Voting
Trip	40	130.00	200	°C	
Alarm	40	110.00	200	°C	

FUNCTION & SET POINT	MIN	DEFAULT	MAX	UNIT	PROGRAM SELECTION
RTD M2 #1:					
Name	RTD Module 2 #1				
Type		Disable			<input type="checkbox"/> Disable <input type="checkbox"/> Ni120 Ω <input type="checkbox"/> Pt100 Ω <input type="checkbox"/> Cu10 Ω <input type="checkbox"/> Ni100 Ω
Function		Stator			<input type="checkbox"/> Stator <input type="checkbox"/> Load <input type="checkbox"/> Bearing <input type="checkbox"/> Ambient <input type="checkbox"/> Stator Voting <input type="checkbox"/> Load Voting <input type="checkbox"/> Bearing Voting <input type="checkbox"/> Ambient Voting
Trip	40	130.00	200	°C	
Alarm	40	110.00	200	°C	
RTD M2 #2:					
Name	RTD Module 2 #2				
Type		Disable			<input type="checkbox"/> Disable <input type="checkbox"/> Ni120 Ω <input type="checkbox"/> Pt100 Ω <input type="checkbox"/> Cu10 Ω <input type="checkbox"/> Ni100 Ω
Function		Stator			<input type="checkbox"/> Stator <input type="checkbox"/> Load <input type="checkbox"/> Bearing <input type="checkbox"/> Ambient <input type="checkbox"/> Stator Voting <input type="checkbox"/> Load Voting <input type="checkbox"/> Bearing Voting <input type="checkbox"/> Ambient Voting
Trip	40	130.00	200	°C	
Alarm	40	110.00	200	°C	
RTD M2 #3:					
Name	RTD Module 2 #3				
Type		Disable			<input type="checkbox"/> Disable <input type="checkbox"/> Ni120 Ω <input type="checkbox"/> Pt100 Ω <input type="checkbox"/> Cu10 Ω <input type="checkbox"/> Ni100 Ω
Function		Stator			<input type="checkbox"/> Stator <input type="checkbox"/> Load <input type="checkbox"/> Bearing <input type="checkbox"/> Ambient <input type="checkbox"/> Stator Voting <input type="checkbox"/> Load Voting <input type="checkbox"/> Bearing Voting <input type="checkbox"/> Ambient Voting
Trip	40	130.00	200	°C	
Alarm	40	110.00	200	°C	
RTD M2 #4:					
Name	RTD Module 2 #4				
Type		Disable			<input type="checkbox"/> Disable <input type="checkbox"/> Ni120 Ω <input type="checkbox"/> Pt100 Ω <input type="checkbox"/> Cu10 Ω <input type="checkbox"/> Ni100 Ω
Function		Stator			<input type="checkbox"/> Stator <input type="checkbox"/> Load <input type="checkbox"/> Bearing <input type="checkbox"/> Ambient <input type="checkbox"/> Stator Voting <input type="checkbox"/> Load Voting <input type="checkbox"/> Bearing Voting <input type="checkbox"/> Ambient Voting
Trip	40	130.00	200	°C	
Alarm	40	110.00	200	°C	

FUNCTION & SET POINT	MIN	DEFAULT	MAX	UNIT	PROGRAM SELECTION
RTD M2 #5:					
Name	RTD Module 2 #5				
Type		Disable			<input type="checkbox"/> Disable <input type="checkbox"/> Ni120 Ω <input type="checkbox"/> Pt100 Ω <input type="checkbox"/> Cu10 Ω <input type="checkbox"/> Ni100 Ω
Function		Stator			<input type="checkbox"/> Stator <input type="checkbox"/> Load <input type="checkbox"/> Bearing <input type="checkbox"/> Ambient <input type="checkbox"/> Stator Voting <input type="checkbox"/> Load Voting <input type="checkbox"/> Bearing Voting <input type="checkbox"/> Ambient Voting
Trip	40	130.00	200	°C	
Alarm	40	110.00	200	°C	
RTD M2 #6:					
Name	RTD Module 2 #6				
Type		Disable			<input type="checkbox"/> Disable <input type="checkbox"/> Ni120 Ω <input type="checkbox"/> Pt100 Ω <input type="checkbox"/> Cu10 Ω <input type="checkbox"/> Ni100 Ω
Function		Stator			<input type="checkbox"/> Stator <input type="checkbox"/> Load <input type="checkbox"/> Bearing <input type="checkbox"/> Ambient <input type="checkbox"/> Stator Voting <input type="checkbox"/> Load Voting <input type="checkbox"/> Bearing Voting <input type="checkbox"/> Ambient Voting
Trip	40	130.00	200	°C	
Alarm	40	110.00	200	°C	
RTD M2 #7:					
Name	RTD Module 2 #7				
Type		Disable			<input type="checkbox"/> Disable <input type="checkbox"/> Ni120 Ω <input type="checkbox"/> Pt100 Ω <input type="checkbox"/> Cu10 Ω <input type="checkbox"/> Ni100 Ω
Function		Stator			<input type="checkbox"/> Stator <input type="checkbox"/> Load <input type="checkbox"/> Bearing <input type="checkbox"/> Ambient <input type="checkbox"/> Stator Voting <input type="checkbox"/> Load Voting <input type="checkbox"/> Bearing Voting <input type="checkbox"/> Ambient Voting
Trip	40	130.00	200	°C	
Alarm	40	110.00	200	°C	
RTD M2 #8:					
Name	RTD Module 2 #8				
Type		Disable			<input type="checkbox"/> Disable <input type="checkbox"/> Ni120 Ω <input type="checkbox"/> Pt100 Ω <input type="checkbox"/> Cu10 Ω <input type="checkbox"/> Ni100 Ω
Function		Stator			<input type="checkbox"/> Stator <input type="checkbox"/> Load <input type="checkbox"/> Bearing <input type="checkbox"/> Ambient <input type="checkbox"/> Stator Voting <input type="checkbox"/> Load Voting <input type="checkbox"/> Bearing Voting <input type="checkbox"/> Ambient Voting
Trip	40	130.00	200	°C	
Alarm	40	110.00	200	°C	

FUNCTION & SET POINT	MIN	DEFAULT	MAX	UNIT	PROGRAM SELECTION
RTD M3 #1:					
Name	RTD Module 3 #1				
Type		Disable			<input type="checkbox"/> Disable <input type="checkbox"/> Ni120 Ω <input type="checkbox"/> Pt100 Ω <input type="checkbox"/> Cu10 Ω <input type="checkbox"/> Ni100 Ω
Function		Stator			<input type="checkbox"/> Stator <input type="checkbox"/> Load <input type="checkbox"/> Bearing <input type="checkbox"/> Ambient <input type="checkbox"/> Stator Voting <input type="checkbox"/> Load Voting <input type="checkbox"/> Bearing Voting <input type="checkbox"/> Ambient Voting
Trip	40	130.00	200	°C	
Alarm	40	110.00	200	°C	
RTD M3 #2:					
Name	RTD Module 3 #2				
Type		Disable			<input type="checkbox"/> Disable <input type="checkbox"/> Ni120 Ω <input type="checkbox"/> Pt100 Ω <input type="checkbox"/> Cu10 Ω <input type="checkbox"/> Ni100 Ω
Function		Stator			<input type="checkbox"/> Stator <input type="checkbox"/> Load <input type="checkbox"/> Bearing <input type="checkbox"/> Ambient <input type="checkbox"/> Stator Voting <input type="checkbox"/> Load Voting <input type="checkbox"/> Bearing Voting <input type="checkbox"/> Ambient Voting
Trip	40	130.00	200	°C	
Alarm	40	110.00	200	°C	
RTD M3 #3:					
Name	RTD Module 3 #3				
Type		Disable			<input type="checkbox"/> Disable <input type="checkbox"/> Ni120 Ω <input type="checkbox"/> Pt100 Ω <input type="checkbox"/> Cu10 Ω <input type="checkbox"/> Ni100 Ω
Function		Stator			<input type="checkbox"/> Stator <input type="checkbox"/> Load <input type="checkbox"/> Bearing <input type="checkbox"/> Ambient <input type="checkbox"/> Stator Voting <input type="checkbox"/> Load Voting <input type="checkbox"/> Bearing Voting <input type="checkbox"/> Ambient Voting
Trip	40	130.00	200	°C	
Alarm	40	110.00	200	°C	
RTD M3 #4:					
Name	RTD Module 3 #4				
Type		Disable			<input type="checkbox"/> Disable <input type="checkbox"/> Ni120 Ω <input type="checkbox"/> Pt100 Ω <input type="checkbox"/> Cu10 Ω <input type="checkbox"/> Ni100 Ω
Function		Stator			<input type="checkbox"/> Stator <input type="checkbox"/> Load <input type="checkbox"/> Bearing <input type="checkbox"/> Ambient <input type="checkbox"/> Stator Voting <input type="checkbox"/> Load Voting <input type="checkbox"/> Bearing Voting <input type="checkbox"/> Ambient Voting
Trip	40	130.00	200	°C	
Alarm	40	110.00	200	°C	

FUNCTION & SET POINT	MIN	DEFAULT	MAX	UNIT	PROGRAM SELECTION
RTD M3 #5:					
Name	RTD Module 3 #5				
Type		Disable			<input type="checkbox"/> Disable <input type="checkbox"/> Ni120 Ω <input type="checkbox"/> Pt100 Ω <input type="checkbox"/> Cu10 Ω <input type="checkbox"/> Ni100 Ω
Function		Stator			<input type="checkbox"/> Stator <input type="checkbox"/> Load <input type="checkbox"/> Bearing <input type="checkbox"/> Ambient <input type="checkbox"/> Stator Voting <input type="checkbox"/> Load Voting <input type="checkbox"/> Bearing Voting <input type="checkbox"/> Ambient Voting
Trip	40	130.00	200	°C	
Alarm	40	110.00	200	°C	
RTD M3 #6:					
Name	RTD Module 3 #6				
Type		Disable			<input type="checkbox"/> Disable <input type="checkbox"/> Ni120 Ω <input type="checkbox"/> Pt100 Ω <input type="checkbox"/> Cu10 Ω <input type="checkbox"/> Ni100 Ω
Function		Stator			<input type="checkbox"/> Stator <input type="checkbox"/> Load <input type="checkbox"/> Bearing <input type="checkbox"/> Ambient <input type="checkbox"/> Stator Voting <input type="checkbox"/> Load Voting <input type="checkbox"/> Bearing Voting <input type="checkbox"/> Ambient Voting
Trip	40	130.00	200	°C	
Alarm	40	110.00	200	°C	
RTD M3 #7:					
Name	RTD Module 3 #7				
Type		Disable			<input type="checkbox"/> Disable <input type="checkbox"/> Ni120 Ω <input type="checkbox"/> Pt100 Ω <input type="checkbox"/> Cu10 Ω <input type="checkbox"/> Ni100 Ω
Function		Stator			<input type="checkbox"/> Stator <input type="checkbox"/> Load <input type="checkbox"/> Bearing <input type="checkbox"/> Ambient <input type="checkbox"/> Stator Voting <input type="checkbox"/> Load Voting <input type="checkbox"/> Bearing Voting <input type="checkbox"/> Ambient Voting
Trip	40	130.00	200	°C	
Alarm	40	110.00	200	°C	
RTD M3 #8:					
Name	RTD Module 3 #8				
Type		Disable			<input type="checkbox"/> Disable <input type="checkbox"/> Ni120 Ω <input type="checkbox"/> Pt100 Ω <input type="checkbox"/> Cu10 Ω <input type="checkbox"/> Ni100 Ω
Function		Stator			<input type="checkbox"/> Stator <input type="checkbox"/> Load <input type="checkbox"/> Bearing <input type="checkbox"/> Ambient <input type="checkbox"/> Stator Voting <input type="checkbox"/> Load Voting <input type="checkbox"/> Bearing Voting <input type="checkbox"/> Ambient Voting
Trip	40	130.00	200	°C	
Alarm	40	110.00	200	°C	

APPENDIX C MPS MODBUS PROTOCOL

C.1 PROTOCOL

The MPS implements the Modbus[®] RTU protocol as described in the Gould Modbus Reference Guide, Publication PI-MBUS-300 Rev. B.

The communications system consists of a single master and up to thirty-two MPS-CTU slaves connected using a 2-wire RS-485 network. If the master does not have an RS-485 port, an RS-232 to RS-485 converter is required. The converter must have automatic send-data control (SD). SD control does not require hand-shaking lines since it uses the data line to control the transmit/receive line on the RS-485 transceivers.

Only the master can initiate a message transaction. Messages can be addressed to individual slaves or they can be broadcast messages. Broadcast messages are executed on the MPS slaves but unlike individually addressed messages, the slaves do not generate a reply message.

C.2 MESSAGE SYNCHRONIZATION

Message synchronization is accomplished by detection of an idle communication line. The communication line is considered idle when no communication exists for an equivalent delay of 3.5 characters.

The first byte received after idle-line detection is interpreted as the address byte of the next message. Message bytes must be transmitted in a continuous stream until the complete message has been sent. If a delay of more than 3.5 characters exists within the message, the message is discarded.

Response messages from the MPS are delayed by at least 3.5 character delays.

C.3 ERROR CHECKING

Modbus RTU uses a 16-bit cyclic redundancy check (CRC). The error check includes all of the message bytes, starting with the first address byte.

When a CRC error is detected, the message is discarded and there will be no response.

If the CRC check is correct but the internal data in the message is not correct, the MPS will respond with an exception response code.

C.4 FUNCTION CODES SUPPORTED

The MPS Modbus Protocol supports the following function codes:

- Read Holding Registers (Function Code 3)
- Read Input Registers (Function Code 4)
- Write Single Register (Function Code 6)
- Write Multiple Registers (Function Code 16)
- Command Instruction (Function Code 5)

Function Codes 3 and 4 perform the same function in the MPS.

Registers in Modbus start at 40001 decimal and the register address generated for this register is 0.

C.4.1 APPLICATION LAYER

The hexadecimal system is used. Value representations use the “C” convention. For hexadecimal, 0x precedes the value.

C.4.2 READ INPUT/HOLDING REGISTERS (CODE 04/03)

The first byte of the read message is the slave address. The second byte is the function code. Bytes three and four indicate the starting register. The next two bytes specify the number of 16-bit registers to read. The last two bytes contain the CRC code for the message.

TABLE C.1 READ REGISTERS (CODE 04/03)

HEX BYTE	DESCRIPTION
Byte 1	Slave Address
Byte 2	Function Code
Byte 3	MSB Register Address
Byte 4	LSB Register Address
Byte 5	MSB Number of Registers
Byte 6	LSB Number of Registers
Byte 7	LSB CRC
Byte 8	MSB CRC

The two-byte values of starting register and number of registers to read are transmitted with the high-order byte followed by the low-order byte.

The CRC value is sent with the LSB followed by the MSB.

The following message will obtain the value of register 1 (Modbus 40002) from slave 1. Note that Modbus registers are numbered from zero (40001 = zero, 40002 = one, etc.):

0x01 | 0x03 | 0x00 | 0x01 | 0x00 | 0x01 | 0xD5 | 0xCA

Modicon Modbus[®] is a registered trademark of Schneider Electric.

The addressed slave responds with its address and Function Code 3, followed by the information field. The information field contains an 8-bit byte count and the 16-bit data from the slave. The byte count specifies the number of bytes of data in the information field. The data in the information field consists of 16-bit data arranged so that the MSB is followed by the LSB.

The maximum number of 16-bit registers that can be read is 120.

C.4.3 WRITE TO REGISTER

Function Code 6 or 16 is used to make set-point changes.

C.4.3.1 WRITE SINGLE REGISTER (CODE 6)

The function code format for writing a single register is shown in Table C.2.

The message consists of the MPS address followed by the Function Code 6 and two 16-bit values. The first 16-bit value specifies the register to be modified and the second value is the 16-bit data.

Provided no errors occurred, the slave will re-send the original message to the master. The response message is returned only after the command has been executed by the MPS.

The following message will set register 3 to 300 in slave 5:

0x05 | 0x06 | 0x00 | 0x03 | 0x01 | 0x2C | 0x78 | 0x03

TABLE C.2 WRITE SINGLE REGISTER (CODE 6)

HEX BYTE	DESCRIPTION
Byte 1	Slave Address
Byte 2	Function Code
Byte 3	MSB Register Address
Byte 4	LSB Register Address
Byte 5	MSB of Data
Byte 6	LSB of Data
Byte 7	LSB of CRC
Byte 8	MSB of CRC

C.4.3.2 WRITE MULTIPLE REGISTERS (CODE 16)

The function-code format in Table C.3 can be used for writing single or multiple registers.

TABLE C.3 WRITE MULTIPLE REGISTERS (CODE 16)

BYTE #	DESCRIPTION
Byte 1	Slave Address
Byte 2	Function Code
Byte 3	MSB Register Address
Byte 4	LSB Register Address
Byte 5	MSB of Quantity
Byte 6	LSB of Quantity
Byte 7	Byte Count
.	MSB of Data
.	LSB of Data
.	LSB of CRC
Byte n	MSB of CRC

The MPS will reply with the slave address, function code, register address, and the quantity followed by the CRC code for a total of 8 bytes.

C.4.4 COMMAND INSTRUCTION (CODE 5)

Modbus Function Code 5 (Force Single Coil) is used to issue commands to the MPS. The format for the message is listed in Table C.4 and the command code actions and corresponding coil number are listed in Table C.5.

TABLE C.4 COMMAND FORMAT CODE 5

HEX BYTE	DESCRIPTION
Byte 1	Slave Address
Byte 2	Function Code
Byte 3	MSB of Command Code
Byte 4	LSB of Command Code
Byte 5	Fixed at 0xff
Byte 6	Fixed at 00
Byte 7	LSB of CRC
Byte 8	MSB of CRC

TABLE C.5 SUPPORTED COMMANDS

COMMAND CODE	COIL NUMBER	ACTION
0x0000	1	STOP
0x0001	2	START1
0x0002	3	START2
0x0003	4	Reset Trips
0x0004	5	Set Real-Time Clock
0x0005	6	Clear Data-Logging Records
0x0006	7	Clear Trip Counters
0x0007	8	Clear Energy Totals
0x0008	9	Clear Running Hours
0x0009	10	Emergency I ² t and Trip Reset
0x000A	11	Select Local Control
0x000B	12	De-select Local Control
0x000C	13	Re-enable Temperature Protection
0x000D	14	Start Trace

Except for a broadcast address, the slave will return the original packet to the master.

C.4.5 COMMAND INSTRUCTIONS USING WRITE COMMANDS

For PLC's not supporting Function Code 5, MPS commands can be issued using Write Single Register (Code 6) and Write Multiple Register (Code 16).

Commands are written to MPS register 6 (Modbus register 40007). Supported commands are listed in the COMMAND CODE column in Table C.5.

When using the Write Multiple Registers function code, the write should be to the single MPS Register 6. If multiple registers are written starting at MPS Register 6, the first data element will be interpreted as the command code but no other registers will be written. If the command is successful, the MPS will return a valid response message.

C.4.6 EXCEPTION RESPONSES

The MPS supports the following exception responses:

- Boundary Error (1)—Applies to writes of 32-bit values. The high-order word must be written first followed by the write to the low-order word. If this sequence is not followed, a Boundary Error is returned and the value will not stored. This does not apply on read requests.
- Address Error (2)—All accesses to communication registers must be within the specified address range or the Address Error code is returned.
- Command Error (3)—This error code is returned if the command code is not supported.
- Illegal Function Code (4)—The function code (Byte 2) is not supported.

The exception message consists of the slave address followed by a retransmission of the original function code. The function code will have the most-significant bit set to indicate an error. The 8-bit byte following the function code is the exception response code. The 16-bit CRC is at the end of the message.

C.5 MPS DATABASE

Appendix E contains the Modbus Register in the Communications Database Table. The table starts at register 0 (Modbus 40001) and each register is 16-bits wide. Types “long” and “float” are 32-bit values. For both long and float types, the low-order word is transmitted first followed by the high-order word. Word values have the high byte followed by the low byte. Float types as per IEEE 754 Floating-Point Standard. All bytes of long and float types must be written using one message or an error will result. This does not apply for read commands.

C.5.1 DATA RECORDS

Only one event record can be read at a time. Record data is for the record indicated by the Record Selector. To select a record, write the record number to Record Selector and then read the values in the record. Record Head points to the next available record. The last event record captured is at Record Head minus one.

Both Record Selector and Record Head values are in the range of 0 to 63. Values outside this range will select record 0.

C.5.2 CUSTOM DATA ACCESS

Data access can be customized with the User-Defined Registers and the User-Data Registers.

User-Defined Registers are located in non-volatile memory and contain the register numbers from which data is required. To access the data, read the corresponding User-Data Registers.

The format of the User Data is a function of the corresponding register entered in the User-Defined-Register area.

C.6 NETWORK TIMEOUT

The MPS can be configured to trip or alarm on a network timeout using the *Setup | Hardware | Network Comms* menu. The *Net Trip Action* and *Net Alarm Action* set points set the actions to be taken when a timeout occurs. To prevent a timeout, a valid message, addressed to the slave, must be received at time intervals less than five seconds.

NOTE: Set protocol to *None* before selecting *Network Error* actions; then, select protocol.

C.7 SPECIFICATIONS

Interface.....	Isolated RS-485, 2-wire, multi-drop, half duplex.
Protocol	Modbus RTU
Baud Rate	1,200 to 19,200 bit/s ⁽³⁾
Bit Format	8 bits, no parity, one stop bit ⁽¹⁾
Number of CTU's Connected	Maximum of 32 units
Bus length.....	1,200 m (4,000') total ⁽²⁾

⁽¹⁾ Terminal “-” is negative with respect to terminal “+” for a binary 1 (MARK or OFF) state.
Terminal “-” is positive with respect to terminal “+” for a binary 0 (SPACE or ON) state.

⁽²⁾ For line lengths exceeding 10 m (30’), 150-Ω terminations are required at the cable ends.

⁽³⁾ Error rate is 1 byte/120 kB at 19,200 bit/s. For high reliability, use 9600 bit/s.

This page intentionally left blank.

APPENDIX D MPS A-B DF1 PROTOCOL

D.1 PROTOCOL

The MPS A-B® Protocol is based on the half-duplex master/slave Allen-Bradley (A-B) Data Highway Protocol (DF1) as described in Allen-Bradley Bulletin 1770-6.5.16 October 1996. This publication is available from the A-B web site at www.ab.com.

The communications system consists of a single master and up to thirty-two slaves connected to a 2-wire RS-485 multi-drop network. MPS Control Units are slave devices on this network.

If the master does not have an RS-485 port, an RS-232 to RS-485 converter is required. The RS-485 converter should have automatic send-data control (SD). SD control does not require handshaking lines since it uses the data line to control the RS-485 transmitter. The SE-485-DIN converter is recommended. It includes optical isolation and baud rate selections from 9,600 to 57,600 bits per second. For additional information on converters, see Technical Information TI 9.9.

The MPS supports the DF1 commands shown in Table D.1. Each PLC has limitations when using a particular command. Determine the best command to use for a particular application.

TABLE D.1 DF1 COMMANDS

COMMAND	CMD	FNC
Unprotected Read	01	-
Unprotected Write	08	-
Typed Read	0F	68
Typed Write	0F	67
Typed Logical Read	0F	A2
Typed Logical Write	0F	AA

The PLC-5 and SLC 500 support reading and writing to integer files (Type N) and float files (Type F). Since MPS meter values are float types, these will typically be stored in a PLC Type-F file. It is also possible to read float types from the MPS as two integers; however, further processing is required to obtain the float value.

The PLC requires two communication ports—a PLC programming port and an MPS communications port. Typically, a DH+ port will be used for PLC programming and the RS-232 port is used for MPS communications via an SE-485-DIN converter.

A-B® is a registered trademark of Rockwell International Corporation.

D.2 PLC-5 / SLC 500 CHANNEL-0 SETUP

The RS-232 Channel-0 port is set up for a DF1 half-duplex master. Set the Channel-0 baud rate and CRC to match the MPS settings. The parity bit is not supported on the MPS. Where applicable, set *Reply Message Wait* to 100 ms.

Additional recommended PLC settings:

- DF1 Retries = 3
- RTS Send Delay = 1 (20 ms)
- RTS Off Delay = 0
- Ack timeout = 5 (100 ms)
- Reply msg wait = 3 (60 ms)

For the polling mode, select MESSAGE BASED (DO NOT ALLOW SLAVE TO INITIATE MESSAGES) or STANDARD (MULTIPLE MESSAGE-TRANSFER PER NODE SCAN). The MPS can buffer up to 3 messages. The selection MESSAGE BASED (DO NOT ALLOW SLAVE TO INITIATE MESSAGES) is recommended.

D.3 TYPED-READ

The Typed-Read message is used to read data from the MPS. The Typed-Read message requires a Control Block where the message configuration is stored. In the SLC, this is normally N7:0 but could be any other file that supports the control-block data. Use the following MSG settings:

- Read/Write: Read
- Target Device: PLC5 of SLC for SLC500 or Control Logix
- Local/Remote: Local
- Control Block: N7:0

NOTE: For the PLC-5, the message block must be of type MG so that the channel number can be set in the message setup screen.

The Setup screen is used to specify file information. In the *This Controller* section, *Data Table Address* is the destination in the PLC where data is to be stored. This can be a float (Fx:x) file or an integer (Nx:x) file. *Element Size* must be set to the number of elements to transfer. This is a decimal value and this value is limited in some controllers. In the SLC 500, the maximum value for integers is 100 and for floats it is 50.

In *Target Device*, set *Data Table Address* to the A-B File address listed in Appendix E. The A-B File in Appendix E is coded as FILE:ELEMENT. To read or write the element as floats, the PLC-5 address would be <F><FILE>:<ELEMENT> (Example F9:222). To read or write the element as integers, add 20 to the file number and precede with N, <N><FILE+20>:<ELEMENT> (Example N29:222). *Local Address* is the MPS address.

Example settings for reading 25 registers as float type (25 meter readings):

Data Table Address:F8:0

Element Size:25

Target Device Data

Table Address:F6:0

Local Address:9 (Must match MPS setting)

NOTE: To read float values, both data table addresses must be specified as float (F) type.

Example settings for reading a block of 100 registers (16-bit integer):

This could be a mix of float and integer values since float can be transferred as two integers in the MPS.

Data Table Address:N9:0

Element Size:100

Target Device Data

Table Address:N23:264 (Start of Digital Inputs)

Local Address:9 (Must match MPS setting)

If an MPS float has been read into the PLC as two integers and stored in an N-type file, the float can be recovered by using two copy commands. Assume that the two integers from the MPS read command are stored in N9:0 and N9:1. The first copy command is used to swap the two words so they are in the correct order; copy N9:0 to N9:11, and copy N9:1 to N9:10. The second copy command will copy the two integers to the F-type file; copy N9:10 to F8:0 with a size of 1. The two integers are now combined correctly as a single 4-byte float located in F8:0.

D.4 TYPED-WRITE

The Typed-Write message is used to write data to the MPS.

Read/Write: Write
Target Device: PLC5 or SLC for SLC500 or Control Logix
Local/Remote: Local
Control Block: N7:0

The Setup screen is used to specify file information. In the *This Controller* section, *Data Table Address* is the source file in the SLC. This can be a float (Fx:x) file or an integer (Nx:x) file. *Element Size* must be set to the number of elements to transfer. For the MPS, the maximum element size is 100 for integers and 50 for floats.

In *Target Device*, set *Data Table Address* to the A-B File address listed in Appendix E. Both integer and float values sent from the SLC are in the correct byte order and interpreted correctly by the MPS. The MPS will do a range check on all messages to ensure valid data.

Local Address is the MPS address.

Example settings for writing a single float to set the FLA Rating:

Data-Table Address:F8:0 (Location of FLA value)

Element Size:1

Target-Device Data-

Table Address:F3:225

Local Address:9 (Must match MPS setting)

Reset commands to the MPS are issued by writing an integer command code to MPS Register 6 (N23:6)

A command message should only be issued when the command is required.

Valid commands are shown Table D.2.

TABLE D.2 MPS COMMANDS

COMMAND CODE	ACTION
0x0000	STOP
0x0001	START1
0x0002	START2
0x0003	Reset Trips
0x0004	Set Real-Time Clock
0x0005	Clear Data-Logging Records
0x0006	Clear Trip Counters
0x0007	Clear Energy Totals
0x0008	Clear Running Hours
0x0009	Emergency I ² t and Trip Reset
0x000A	Select Local Control
0x000B	De-select Local Control
0x000C	Re-enable Temperature Protection
0x000D	Start Trace

Example settings for writing an MPS reset command.

Data-Table Address:N9:0 (Reset code = 3)

Element Size:1

Target-Device Data-

Table Address:N23:6 (MPS Command Register location)

Local Address:9 (Must match MPS setting)

D.5 UNPROTECTED READ/WRITE

For PLC-2 and PLC-3 processors not supporting Typed Read/Write messages, Unprotected Read/Write commands can be used. For these messages, the data address is the Octal value of the MPS Register in Appendix E. The size is the number of registers. The maximum number of registers that can be transferred in a single message is 100.

Unprotected Read/Write commands are used by the SE-Comm-MPS communication program.

D.6 TYPED LOGICAL READ/WRITE

The Typed Logical Read (CMD = 0F, FNC = A2) and Typed Logical Write (CMD = 0F, FNC = AA) messages are supported by the full line of SLC 500 processors and Prosoft MVIXX-DFCM communication interfaces.

Both float (F) and integer (N) types are supported. Unlike the typed commands in Section D.3 and D.4 a file offset is not required for integer values. Use the A-B file address as listed in the MPS manual Appendix E and precede the address with F for float values and N for integer values.

The maximum number of integers and floats that can be read is 100 and 50 respectively.

Reset commands to the MPS are issued by writing one of the COMMAND CODES listed in Table D.2 to Register 6 (N3:6).

D.7 DATA RECORDS

Only one event record can be read at a time. Data is for the record indicated by the Record Selector. To select a record, write the record number to Record Selector and then read the values in the record. Record-Head points to the next available record. The last event record captured is at Record Head minus one.

Both Record-Selector and Record-Head values are in the range of 0 to 63. Values outside this range will select record 0.

D.8 CUSTOM DATA ACCESS

Data access can be customized with the User-Defined Registers and the User Data Register.

Enter the required data-register numbers in the User-Defined Registers. The format of user data is a function of the corresponding register.

To access the data, read the corresponding User-Data Register.

D.9 NETWORK TIMEOUT

The MPS can be configured to trip or alarm on a network timeout using the *Setup | Hardware | Network Comms* menu. The *Net Trip Action* and *Net Alarm Action* set points set the actions to be taken when a timeout occurs. To prevent a timeout, a valid message, addressed to the slave, must be received at time intervals less than five seconds.

NOTE: Set protocol to *None* before selecting *Network Error* actions; then, select protocol.

D.10 SPECIFICATIONS

Interface	Isolated RS-485, 2-wire, multi-drop, half duplex
Protocol	Modbus RTU
Baud Rate	1,200 to 19,200 bit/s ⁽³⁾
Bit Format	8 bits, no parity, one stop bit ⁽¹⁾
Number of CTU's Connected	Maximum of 32 units
Bus length.....	1,200 m (4,000') total ⁽²⁾

- ⁽¹⁾ Terminal “-” is negative with respect to terminal “+” for a binary 1 (MARK or OFF) state.
Terminal “-” is positive with respect to terminal “+” for a binary 0 (SPACE or ON) state.
- ⁽²⁾ For line lengths exceeding 10 m (30’), 150-Ω terminations are required at the cable ends.
- ⁽³⁾ Error rate is 1 byte/120 kB at 19,200 bit/s. For high reliability, use 9600 bit/s.

This page intentionally left blank.

**APPENDIX E
COMMUNICATIONS DATABASE TABLE FOR V. 3.04**

MPS REGISTER (DECIMAL)	MODBUS REGISTER (DECIMAL)	A-B FILE (DECIMAL) (NOTE 4)	DESCRIPTION	ACCESS	RANGE	TYPE
Model Information						
0	40001	3:000	Model Code (201)	Read Only		T3
1			Software Version	Read Only		T3
2			Serial Number	Read Only		T2 (Low)
3						T2 (High)
4						
5			Diagnostic Code	Read Only		T3
6	N/A		DF1 Command Register	Write Only		T37
Overload						
8	40009	3:8	Trip Action	R/W	0 - 7	T42
9			Model Type	R/W	0 - 1	T33
10			I ² t Start Inhibit	R/W	0 - 1	T6
11			K-Factor	R/W	0 - 10	T1 (Low)
12						T1 (High)
13			Locked-Rotor Current	R/W	1.5 - 10 x FLA	T1 (Low)
14						T1 (High)
15			Locked-Rotor Time Cold	R/W	0.2 - 100 s	T1 (Low)
16						T1 (High)
17			Locked-Rotor Time Hot	R/W	0.2 - 100 s	T1 (Low)
18						T1 (High)
19			Cooling Factor	R/W	0.1 - 50	T1 (Low)
20						T1 (High)
21			I ² t Inhibit Level	R/W	0.1 - 0.9	T1 (Low)
22						T1 (High)
23			I ² t Alarm level	R/W	0.5 - 1.0	T1 (Low)
24						T1 (High)
25			I ² t Alarm Action	R/W	0 - 7	T43
26			I ² t Reset Type	R/W	0 - 2	T38
Overcurrent						
32	40033	3:32	Trip Action	R/W	0 - 7	T42
33			Trip Level	R/W	1 - 15 x I _p	T1 (Low)
34						T1 (High)
35			Trip Delay	R/W	0 - 10 s	T1 (Low)
36						T1 (High)
Aux Overcurrent						
40	40041	3:40	Trip Action	R/W	0 - 7	T42
41			Trip Level	R/W	1 - 15 x I _p	T1 (Low)
42						T1 (High)
43			Trip Delay	R/W	0 - 10 s	T1 (Low)
44						T1 (High)

MPS REGISTER (DECIMAL)	MODBUS REGISTER (DECIMAL)	A-B FILE (DECIMAL) (NOTE 4)	DESCRIPTION	ACCESS	RANGE	TYPE
Reduced Overcurrent						
45	40046	3:45	Trip Action	R/W	0 - 7	T42
46			Trip Level	R/W	1 - 15 x I _p	T1 (Low)
47						T1 (High)
Earth Fault						
48	40049	3:48	Trip Action	R/W	0 - 7	T42
49			Spare			
50			Trip Level	R/W	0.05 - 1.0 x I _e	T1(Low)
51						T1(High)
52			Trip Delay	R/W	0 - 100 s	T1(Low)
53						T1(High)
54			Alarm Level	R/W	0.05 - 1.0 x I _e	T1(Low)
55						T1(High)
56			Alarm Delay	R/W	0 - 100 s	T1(Low)
57						T1(High)
58			Alarm Action	R/W	0 - 7	T43
Jam						
64	40065	3:64	Trip Action	R/W	0 - 7	T42
65			Trip Level	R/W	1 - 10 x FLA	T1(Low)
66						T1(High)
67			Trip Delay	R/W	1 - 100 s	T1(Low)
68						T1(High)
69			Alarm Level	R/W	1 - 10 x FLA	T1(Low)
70						T1(High)
71			Alarm Delay	R/W	1 - 100 s	T1(Low)
72						T1(High)
73			Alarm Action	R/W	0 - 7	T43
Current Unbalance						
80	40081	3:80	Trip Action	R/W	0 - 7	T42
81			Trip Level	R/W	0.05 - 1.0 pu	T1(Low)
82						T1(High)
83			Trip Delay	R/W	1.0 - 100 s	T1(Low)
84						T1(High)
85			Alarm Level	R/W	0.05 - 1.0 pu	T1(Low)
86						T1(High)
87			Alarm Delay	R/W	1.0 - 100 s	T1(Low)
88						T1(High)
89			Alarm Action	R/W	0 - 7	T43
Phase Reverse (I)						
95	40096	3:95	Alarm Action	R/W	0 - 7	T43
96			Trip Action	R/W	0 - 7	T42
97			Trip and Alarm Delay	R/W	1 - 100 s	T1(Low)
98						T1(High)

MPS REGISTER (DECIMAL)	MODBUS REGISTER (DECIMAL)	A-B FILE (DECIMAL) (NOTE 4)	DESCRIPTION	ACCESS	RANGE	TYPE
Phase Loss (I)						
99	40100	3:99	Trip Action	R/W	0 - 7	T42
100			Trip Delay	R/W	1 - 100 s	T1(Low)
101						T1(High)
Voltage Unbalance						
104	40105	3:104	Trip Action	R/W	0 - 7	T42
105			Trip Level	R/W	0.05 - 1.0 pu	T1(Low)
106						T1(High)
107			Trip Delay	R/W	1.0 - 100	T1(Low)
108						T1(High)
109			Alarm Level	R/W	0.05 - 1.0 pu	T1(Low)
110						T1(High)
111			Alarm Delay	R/W	1.0 - 100	T1(Low)
112						T1(High)
113			Alarm Action	R/W	0 - 7	T43
Phase Reverse (V)						
119	40120	3:119	Alarm Action	R/W	0 - 7	T43
120			Trip Action	R/W	0 - 7	T42
121			Trip and Alarm Delay	R/W	1 - 100 s	T1(Low)
122						T1(High)
Phase Loss (V)						
123	40124	3:123	Trip Action	R/W	0 - 7	T42
124			Trip Delay	R/W	1 - 100 s	T1(Low)
125						T1(High)
Undercurrent						
128	40129	3:128	Trip Action	R/W	0 - 7	T42
129			Trip Level	R/W	0.1 - 1.0 x FLA	T1(Low)
130						T1(High)
131			Trip Delay	R/W	1 - 100 s	T1(Low)
132						T1(High)
133			Alarm Level	R/W	0.1 - 1.0 x FLA	T1(Low)
134						T1(High)
135			Alarm Delay	R/W	1 - 100 s	T1(Low)
136						T1(High)
137			Alarm Action	R/W	0 - 7	T43
PTC Temperature						
144	40145	3:144	Trip Action	R/W	0 - 7	T42
145			Alarm Action	R/W	0 - 7	T43
Acceleration Failure—Underspeed						
152	40153	3:152	Trip Action	R/W	0 - 7	T42
153			Speed 1	R/W	1 - 100% FS	T1(Low)
154						T1(High)
155			Time 1	R/W	1 - 1,000 s	T1(Low)
156						T1(High)

MPS REGISTER (DECIMAL)	MODBUS REGISTER (DECIMAL)	A-B FILE (DECIMAL) (NOTE 4)	DESCRIPTION	ACCESS	RANGE	TYPE
157			Speed 2	R/W	1 - 100%-FS	T1(Low)
158						T1(High)
159			Time 2	R/W	1 - 1,000 s	T1(Low)
160						T1(High)
161			Speed 3	R/W	1 - 100% FS	T1(Low)
162						T1(High)
163			Time 3	R/W	1 - 1,000 s	T1(Low)
164						T1(High)
Power Factor – Quadrant 4						
166	40167	3:166	Trip Action	R/W	0 - 7	T42
167			Trip Level	R/W	0.5 - 1.0	T1(Low)
168						T1(High)
169			Trip Delay	R/W	0.2 - 500 s	T1(Low)
170						T1(High)
171			Alarm Level	R/W	0.5 - 1.0	T1(Low)
172						T1(High)
173			Alarm Delay	R/W	0.2 - 500 s	T1(Low)
174						T1(High)
175			Alarm Action	R/W	0 - 7	T43
Overvoltage						
176	40177	3:176	Trip Action	R/W	0 - 7	T42
177			Trip Level	R/W	1 - 1.4 x Vp	T1(Low)
178						T1(High)
179			Trip Delay	R/W	1 - 500 s	T1(Low)
180						T1(High)
181			Alarm Level	R/W	1 - 1.4 x Vp	T1(Low)
182						T1(High)
183			Alarm Delay	R/W	1 - 500 s	T1(Low)
184						T1(High)
185			Alarm Action	R/W	0 - 7	T43
Undervoltage						
192	40193	3:192	Trip Action	R/W	0 - 7	T42
193			Trip Level	R/W	0.5 - 1.0 x Vp	T1(Low)
194						T1(High)
195			Trip Delay	R/W	1 - 500 s	T1(Low)
196						T1(High)
197			Alarm Level	R/W	0.5 - 1.0 x Vp	T1(Low)
198						T1(High)
199			Alarm Delay	R/W	1 - 500 s	T1(Low)
200						T1(High)
201			Alarm Action	R/W	0 - 7	T43
System Ratings						
206			Default Display	R/W	0 - 15	T96
209			V-Connection Type	R/W	0 - 3	T9

MPS REGISTER (DECIMAL)	MODBUS REGISTER (DECIMAL)	A-B FILE (DECIMAL) (NOTE 4)	DESCRIPTION	ACCESS	RANGE	TYPE
210			Phase-CT Primary	R/W	1 - 5,000 A	T1(Low)
211						T1(High)
212			EF-CT Primary	R/W	1 - 5,000 A	T1(Low)
213						T1(High)
214			Input-Voltage Rating	R/W	60 V - 600V	T1(Low)
215						T1(High)
216			Run-Mode Delay	R/W	5 - 120 s	T1(Low)
217						T1(High)
218			Differential-CT Primary Rating	R/W	1 - 5,000 A	T1 (Low)
219						T1 (High)
220			I _p Threshold	R/W	0.1 – 0.5 x I _p	T1 (Low)
221						T1 (High)
223	40224	3:223	Screen Saver	R/W	0 - 1	T6
224	40225	3:224	Frequency	R/W	0 - 1	T10
225			Full-Load Rating #1	R/W	1 - 5,000 A	T1(Low)
226						T1(High)
227			System-Voltage Rating	R/W	120 V - 25 kV	T1(Low)
228						T1(High)
229			Synchronous Speed	R/W	10 - 10,000 RPM	T1(Low)
230						T1(High)
231			Spare			␣
232			Spare			
233			Service Factor	R/W	1 - 1.25	T1(Low)
234						T1(High)
235			Full-Load Rating #2	R/W	1 - 5,000 A	T1(Low)
236						T1(High)
OPI						
237	40238	3:237	OPI-Loss Trip Action	R/W	0 - 7	T42
238			Number of OPI's	R/W	0 - 2	T40
239			Control Enable—REMOTE	R/W	0 - 1	T6
240			Control Enable—OPI	R/W	0 - 1	T6
241			Control Enable—LOCAL		0 - 1	T6
Starter						
242	40243	3:242	Remote Start Sources—Digital Inputs	R/W	0 - 1	T6
243			Remote Start Sources—Network	R/W	0 - 1	T6
244			Remote Start Sources—OPI	R/W	0 - 1	T6
245			OPI Starts	R/W	0 - 1	T6
248			Starter Type	R/W	0 - 15	T11
249			Start Time	R/W	0.1 - 500	T1(Low)
250						T1(High)
251			Stage 1 Delay	R/W	0.1 - 500	T1(Low)
252						T1(High)
253			Stage 2 Delay	R/W	0.1 - 500	T1(Low)
254						T1(High)

MPS REGISTER (DECIMAL)	MODBUS REGISTER (DECIMAL)	A-B FILE (DECIMAL) (NOTE 4)	DESCRIPTION	ACCESS	RANGE	TYPE
255			Stage 3 Delay	R/W	0.1 - 500	T1(Low)
256						T1(High)
257			Backspin-Timer Enable		0 - 1	T6
258			Backspin-Time Delay		0.1 - 3,600 s	T1(Low)
259						T1(High)
Current Transfers						
260	40261	3:260	Transfer Type	R/W	0 - 1	T41
261			Transfer Level	R/W	1.0 - 3.0 x FLA	T1 (Low)
262						T1 (High)
Digital Inputs						
264	40265	3:264	Input 1 Function	R/W	0 - 19	T12
265			Input 1 Bypass Enable	R/W	0 - 1	T6
266			Input 1 Bypass Delay	R/W	0.5 - 100 s	T1(Low)
267						T1(High)
268			Input 1 Trip Delay	R/W	0.01 - 100 s	T1(Low)
269						T1(High)
274			Input 2 Function	R/W	0 - 19	T12
275			Input 2 Bypass Enable	R/W	0 - 1	T6
276			Input 2 Bypass Delay	R/W	0.5 - 100 s	T1(Low)
277						T1(High)
278			Input 2 Trip Delay	R/W	0.01 - 100 s	T1(Low)
279						T1(High)
284			Input 3 Function	R/W	0 - 19	T12
285			Input 3 Bypass Enable	R/W	0 - 1	T6
286			Input 3 Bypass Delay	R/W	0.5 - 100 s	T1(Low)
287						T1(High)
288			Input 3 Trip Delay	R/W	0.01 - 100 s	T1(Low)
289						T1(high)
294			Input 4 Function	R/W	0 - 19	T12
295			Input 4 Bypass Enable	R/W	0 - 1	T6
296			Input 4 Bypass Delay	R/W	0.5 - 100 s	T1(Low)
297						T1(High)
298			Input 4 Trip Delay	R/W	0.01 - 100 s	T1(Low)
299						T1(High)
304			Input 5 Function	R/W	0 - 19	T12
305			Input 5 Bypass Enable	R/W	0 - 1	T6
306			Input 5 Bypass Delay	R/W	0.5 - 100 s	T1(Low)
307						T1(High)
308			Input 5 Trip Delay	R/W	0.01 - 100 s	T1(Low)
309						T1(High)

MPS REGISTER (DECIMAL)	MODBUS REGISTER (DECIMAL)	A-B FILE (DECIMAL) (NOTE 4)	DESCRIPTION	ACCESS	RANGE	TYPE
314			Input 6 Function	R/W	0 - 19	T12
315			Input 6 Bypass Enable	R/W	0 - 1	T6
316			Input 6 Bypass Delay	R/W	0.5 - 100 s	T1(Low)
317						T1(High)
318			Input 6 Trip Delay	R/W	0.01 - 100 s	T1(Low)
319						T1(High)
324			Input 7 Function	R/W	0 - 19	T12
325			Input 7 Bypass Enable	R/W	0 - 1	T6
326			Input 7 Bypass Delay	R/W	0.5 - 100 s	T1(Low)
327						T1(High)
328			Input 7 Delay	R/W	0.01 - 100 s	T1(Low)
329						T1(High)
330			Digital Tachometer Enable	R/W	0 - 1	T6
331			Pulses Per Revolution	R/W	1 - 120	T1(Low)
332						T1(High)
Relay Output Function						
334	40335	3:334	Relay 1 Output Function	R/W	0 - 20	T13
335			Relay 1 Mode	R/W	0 - 1	T14
336			Relay 2 Output Function	R/W	0 - 20	T13
337			Relay 2 Mode	R/W	0 - 1	T14
338			Relay 3 Output Function	R/W	0 - 20	T13
339			Relay 3 Mode	R/W	0 - 1	T14
340			Relay 4 Output Function	R/W	0 - 20	T13
341			Relay 4 Mode	R/W	0 - 1	T14
342			Relay 5 Output Function	R/W	0 - 20	T13
343			Relay 5 Mode	R/W	0 - 1	T14
344			Relay Pulse Time	R/W	0.05 - 10 s	T1(Low)
345						T1(High)
Analog Input						
350	40351	3:350	Analog-Input Function	R/W	0 - 3	T34
351			High-Level Trip	R/W	0.1 - 20.0 mA	T1(Low)
352						T1(High)
353			Low-Level Trip	R/W	0.1 - 20.0 mA	T1(Low)
354						T1(High)
355			Trip Delay	R/W	.01 - 100 s	T1(Low)
356						T1(High)
357			High-Level Alarm	R/W	0.1 - 20.0 mA	T1(Low)
358						T1(High)
359			Low-Level Alarm	R/W	0.1 - 20.0 mA	T1(Low)
360						T1(High)
361			Alarm Delay	R/W	.01 - 100 s	T1(Low)
362						T1(High)

MPS REGISTER (DECIMAL)	MODBUS REGISTER (DECIMAL)	A-B FILE (DECIMAL) (NOTE 4)	DESCRIPTION	ACCESS	RANGE	TYPE	
363			ASD 4-mA Frequency	R/W	0 - 70 Hz	T1(Low)	
364						T1(High)	
365			ASD 20-mA Frequency	R/W	0 - 70 Hz	T1(Low)	
366						T1(High)	
367			Motor 4-mA Speed	R/W	0 - 100%	T1(Low)	
368						T1(High)	
369			Motor 20-mA Speed	R/W	0 - 100%	T1(Low)	
370						T1(High)	
Analog Output							
372			Output Filter	R/W	0 - 1	T6	
373	40374	3:373	Output Parameter	R/W	0 - 16	T15	
			(See Register 856-859 for Analog Output Calibration)				
Network and I/O Module Communications							
374	40375	3:374	DeviceNet Producing Instance	R/W	0 - 9	T82	
375			DeviceNet Consuming Instance	R/W	0 - 4	T83	
379	40380	3:379	RTD-Sensor-Error Alarm Action	R/W	0 - 7	T43	
380			RTD-Module-Error Alarm Action	R/W	0 - 7	T43	
381			Network Alarm Action	R/W	0 - 7	T43	
382			Network Type	R/W	0 - 5	T16	
383			Network Baud Rate	R/W	0 - 7	T17	
384			Error Check	R/W	0 - 2	T18	
385			Network ID	R/W	0 - 255	T1(Low)	
386						T1(High)	
387			Network Trip Action	R/W	0 - 7	T42	
RTD Module							
388	40389	3:388	RTD-Sensor-Error Trip Action	R/W	0 - 7	T42	
389			RTD-Module-Error Trip Action	R/W	0 - 7	T42	
390	40391	4:0	Number of RTD Modules	R/W	0 - 3	T19	
RTD Type							
391	40392	4:1	Module 1 #1 Type	R/W	0 - 4	T20	
392			Module 1 #2 Type	R/W	0 - 4	T20	
393			Module 1 #3 Type	R/W	0 - 4	T20	
394			Module 1 #4 Type	R/W	0 - 4	T20	
395			Module 1 #5 Type	R/W	0 - 4	T20	
396			Module 1 #6 Type	R/W	0 - 4	T20	
397			Module 1 #7 Type	R/W	0 - 4	T20	
398			Module 1 #8 Type	R/W	0 - 4	T20	
399			Module 2 #1 Type	R/W	0 - 4	T20	
400			Module 2 #2 Type	R/W	0 - 4	T20	
401			Module 2 #3 Type	R/W	0 - 4	T20	
402			Module 2 #4 Type	R/W	0 - 4	T20	
403			Module 2 #5 Type	R/W	0 - 4	T20	
404			Module 2 #6 Type	R/W	0 - 4	T20	
405			Module 2 #7 Type	R/W	0 - 4	T20	
406			Module 2 #8 Type	R/W	0 - 4	T20	

MPS REGISTER (DECIMAL)	MODBUS REGISTER (DECIMAL)	A-B FILE (DECIMAL) (NOTE 4)	DESCRIPTION	ACCESS	RANGE	TYPE
407			Module 3 #1 Type	R/W	0 - 4	T20
408			Module 3 #2 Type	R/W	0 - 4	T20
409			Module 3 #3 Type	R/W	0 - 4	T20
410			Module 3 #4 Type	R/W	0 - 4	T20
411			Module 3 #5 Type	R/W	0 - 4	T20
412			Module 3 #6 Type	R/W	0 - 4	T20
413			Module 3 #7 Type	R/W	0 - 4	T20
414			Module 3 #8 Type	R/W	0 - 4	T20
RTD Function						
415	40416	4:25	Module 1 #1 Function	R/W	0 - 7	T21
416			Module 1 #2 Function	R/W	0 - 7	T21
417			Module 1 #3 Function	R/W	0 - 7	T21
418			Module 1 #4 Function	R/W	0 - 7	T21
419			Module 1 #5 Function	R/W	0 - 7	T21
420			Module 1 #6 Function	R/W	0 - 7	T21
421			Module 1 #7 Function	R/W	0 - 7	T21
422			Module 1 #8 Function	R/W	0 - 7	T21
423			Module 2 #1 Function	R/W	0 - 7	T21
424			Module 2 #2 Function	R/W	0 - 7	T21
425			Module 2 #3 Function	R/W	0 - 7	T21
426			Module 2 #4 Function	R/W	0 - 7	T21
427			Module 2 #5 Function	R/W	0 - 7	T21
428			Module 2 #6 Function	R/W	0 - 7	T21
429			Module 2 #7 Function	R/W	0 - 7	T21
430			Module 2 #8 Function	R/W	0 - 7	T21
431			Module 3 #1 Function	R/W	0 - 7	T21
432			Module 3 #2 Function	R/W	0 - 7	T21
433			Module 3 #3 Function	R/W	0 - 7	T21
434			Module 3 #4 Function	R/W	0 - 7	T21
435			Module 3 #5 Function	R/W	0 - 7	T21
436			Module 3 #6 Function	R/W	0 - 7	T21
437			Module 3 #7 Function	R/W	0 - 7	T21
438			Module 3 #8 Function	R/W	0 - 7	T21
RTD Trip1/Alarm1 Setpoints						
446	40447	4:56	Module 1 #1 Trip Level	R/W	40 - 200°C	T1(Low)
447						T1(High)
448			Module 1 #1 Alarm Level	R/W	40 - 200°C	T1(Low)
449						T1(High)
450			Module 1 #2 Trip Level	R/W	40 - 200°C	T1(Low)
451						T1(High)
452			Module 1 #2 Alarm Level	R/W	40 - 200°C	T1(Low)
453						T1(High)
454			Module 1 #3 Trip Level	R/W	40 - 200°C	T1(Low)
455						T1(High)

MPS REGISTER (DECIMAL)	MODBUS REGISTER (DECIMAL)	A-B FILE (DECIMAL) (NOTE 4)	DESCRIPTION	ACCESS	RANGE	TYPE
456			Module 1 #3 Alarm Level	R/W	40 - 200°C	T1(Low)
457						T1(High)
458			Module 1 #4 Trip Level	R/W	40 - 200°C	T1(Low)
459						T1(High)
460			Module 1 #4 Alarm Level	R/W	40 - 200°C	T1(Low)
461						T1(High)
462			Module 1 #5 Trip Level	R/W	40 - 200°C	T1(Low)
463						T1(High)
464			Module 1 #5 Alarm Level	R/W	40 - 200°C	T1(Low)
465						T1(High)
466			Module 1 #6 Trip Level	R/W	40 - 200°C	T1(Low)
467						T1(High)
468			Module 1 #6 Alarm Level	R/W	40 - 200°C	T1(Low)
469						T1(High)
470			Module 1 #7 Trip Level	R/W	40 - 200°C	T1(Low)
471						T1(High)
472			Module 1 #7 Alarm Level	R/W	40 - 200°C	T1(Low)
473						T1(High)
474			Module 1 #8 Trip Level	R/W	40 - 200°C	T1(Low)
475						T1(High)
476			Module 1 #8 Alarm Level	R/W	40 - 200°C	T1(Low)
477						T1(High)
478			Module 2 #1 Trip Level	R/W	40 - 200°C	T1(Low)
479						T1(High)
480			Module 2 #1 Alarm Level	R/W	40 - 200°C	T1(Low)
481						T1(High)
482			Module 2 #2 Trip Level	R/W	40 - 200°C	T1(Low)
483						T1(High)
484			Module 2 #2 Alarm Level	R/W	40 - 200°C	T1(Low)
485						T1(High)
486			Module 2 #3 Trip Level	R/W	40 - 200°C	T1(Low)
487						T1(High)
488			Module 2 #3 Alarm Level	R/W	40 - 200°C	T1(Low)
489						T1(High)
490			Module 2 #4 Trip Level	R/W	40 - 200°C	T1(Low)
491						T1(High)
492			Module 2 #4 Alarm Level	R/W	40 - 200°C	T1(Low)
493						T1(High)
494			Module 2 #5 Trip Level	R/W	40 - 200°C	T1(Low)
495						T1(High)
496			Module 2 #5 Alarm Level	R/W	40 - 200°C	T1(Low)
497						T1(High)
498			Module 2 #6 Trip Level	R/W	40 - 200°C	T1(Low)
499						T1(High)

MPS REGISTER (DECIMAL)	MODBUS REGISTER (DECIMAL)	A-B FILE (DECIMAL) (NOTE 4)	DESCRIPTION	ACCESS	RANGE	TYPE
500			Module 2 #6 Alarm Level	R/W	40 - 200°C	T1(Low)
501						T1(High)
502			Module 2 #7 Trip Level	R/W	40 - 200°C	T1(Low)
503						T1(High)
504			Module 2 #7 Alarm Level	R/W	40 - 200°C	T1(Low)
505						T1(High)
506			Module 2 #8 Trip Level	R/W	40 - 200°C	T1(Low)
507						T1(High)
508			Module 2 #8 Alarm Level	R/W	40 - 200°C	T1(Low)
509						T1(High)
510			Module 3 #1 Trip Level	R/W	40 - 200°C	T1(Low)
511						T1(High)
512			Module 3 #1 Alarm Level	R/W	40 - 200°C	T1(Low)
513						T1(High)
514			Module 3 #2 Trip Level	R/W	40 - 200°C	T1(Low)
515						T1(High)
516			Module 3 #2 Alarm Level	R/W	40 - 200°C	T1(Low)
517						T1(High)
518			Module 3 #3 Trip Level	R/W	40 - 200°C	T1(Low)
519						T1(High)
520			Module 3 #3 Alarm Level	R/W	40 - 200°C	T1(Low)
521						T1(High)
522			Module 3 #4 Trip Level	R/W	40 - 200°C	T1(Low)
523						T1(High)
524			Module 3 #4 Alarm Level	R/W	40 - 200°C	T1(Low)
525						T1(High)
526			Module 3 #5 Trip Level	R/W	40 - 200°C	T1(Low)
527						T1(High)
528			Module 3 #5 Alarm Level	R/W	40 - 200°C	T1(Low)
529						T1(High)
530			Module 3 #6 Trip Level	R/W	40 - 200°C	T1(Low)
531						T1(High)
532			Module 3 #6 Alarm Level	R/W	40 - 200°C	T1(Low)
533						T1(High)
534			Module 3 #7 Trip Level	R/W	40 - 200°C	T1(Low)
535						T1(High)
536			Module 3 #7 Alarm Level	R/W	40 - 200°C	T1(Low)
537						T1(High)
538			Module 3 #8 Trip Level	R/W	40 - 200°C	T1(Low)
539						T1(High)
540			Module 3 #8 Alarm Level	R/W	40 - 200°C	T1(Low)
541						T1(High)
548			Temperature Trip Action	R/W	0 - 7	T42
549			Temperature Alarm Action	R/W	0 - 7	T43

MPS REGISTER (DECIMAL)	MODBUS REGISTER (DECIMAL)	A-B FILE (DECIMAL) (NOTE 4)	DESCRIPTION	ACCESS	RANGE	TYPE
Hot Motor Compensation						
550	40551	4:160	HMC Enable	R/W		T6
551			HMC Maximum Bias	R/W	40 - 200°C	T1(Low)
552						T1(High)
553			HMC Minimum Bias	R/W	40 - 200°C	T1(Low)
554						T1(High)
IRIG Offset						
568	40569	4:178	IRIG Offset (Hours)	R/W	0 - 23	T1(Low)
569						T1(High)
570			IRIG Offset (Minutes)	R/W	0 - 30	T1(Low)
571						T1(High)
Clock Reading						
574	40575	5:0	RTC Date	Read Only		T23(Low)
575						T23(High)
576			RTC Time	Read Only		T23(Low)
577						T23(High)
Strings						
580	40581	5:6	Clock String (Setting Only)	R/W		T31
590			Password (First Four Characters)	R/W		T22
600			System Name	R/W		T22
610			RTD Module 1 #1 Name	R/W		T22
620			RTD Module 1 #2 Name	R/W		T22
630			RTD Module 1 #3 Name	R/W		T22
640			RTD Module 1 #4 Name	R/W		T22
650			RTD Module 1 #5 Name	R/W		T22
660			RTD Module 1 #6 Name	R/W		T22
670			RTD Module 1 #7 Name	R/W		T22
680			RTD Module 1 #8 Name	R/W		T22
690			RTD Module 2 #1 Name	R/W		T22
700			RTD Module 2 #2 Name	R/W		T22
710			RTD Module 2 #3 Name	R/W		T22
720			RTD Module 2 #4 Name	R/W		T22
730			RTD Module 2 #5 Name	R/W		T22
740			RTD Module 2 #6 Name	R/W		T22
750			RTD Module 2 #7 Name	R/W		T22
760			RTD Module 2 #8 Name	R/W		T22
770			RTD Module 3 #1 Name	R/W		T22
780			RTD Module 3 #2 Name	R/W		T22
790			RTD Module 3 #3 Name	R/W		T22
800			RTD Module 3 #4 Name	R/W		T22
810			RTD Module 3 #5 Name	R/W		T22
820			RTD Module 3 #6 Name	R/W		T22
830			RTD Module 3 #7 Name	R/W		T22
840			RTD Module 3 #8 Name	R/W		T22

MPS REGISTER (DECIMAL)	MODBUS REGISTER (DECIMAL)	A-B FILE (DECIMAL) (NOTE 4)	DESCRIPTION	ACCESS	RANGE	TYPE
Analog Output Calibration						
856	40857	5:282	Analog-Output Calibration (Zero)	R/W	0 - 1,000	T1(Low)
857						T1(High)
858			Analog-Output Calibration (FS)	R/W	0 - 1,000	T1(Low)
859						T1(High)
Meter Values						
860	40861	6:0	I _a (A)	Read Only		T1(Low)
861						T1(High)
862			I _b (A)	Read Only		T1(Low)
863						T1(High)
864			I _c (A)	Read Only		T1(Low)
865						T1(High)
866			I _g (A)	Read Only		T1(Low)
867						T1(High)
868			V _{ab} (kV)	Read Only		T1(Low)
869						T1(High)
870			V _{bc} (kV)	Read Only		T1(Low)
871						T1(High)
872			V _{ca} (kV)	Read Only		T1(Low)
873						T1(High)
874			Apparent Power (S) in kVA	Read Only		T1(Low)
875						T1(High)
876			Reactive Power (Q) in kVAR	Read Only		T1(Low)
877						T1(High)
878			Real Power (P) in kW	Read Only		T1(Low)
879						T1(High)
880			Power Factor (-1 to +1)	Read Only		T1(Low)
881						T1(High)
882			Used Thermal Capacity (%)	Read Only		T1(Low)
883						T1(High)
884			Analog Input (mA)	Read Only		T1(Low)
885						T1(High)
886			Trend I ² t (%)	Read Only		T1(Low)
887						T1(High)
888			Positive-Sequence Current (pu)	Read Only		T1(Low)
889						T1(High)
890			Negative-Sequence Current (pu)	Read Only		T1(Low)
891						T1(High)
892			Unbalance (I) (pu)	Read Only		T1(Low)
893						T1(High)
894			Positive-Sequence V (pu)	Read Only		T1(Low)
895						T1(High)
896			Negative-Sequence V (pu)	Read Only		T1(Low)
897						T1(High)

MPS REGISTER (DECIMAL)	MODBUS REGISTER (DECIMAL)	A-B FILE (DECIMAL) (NOTE 4)	DESCRIPTION	ACCESS	RANGE	TYPE
898			Unbalance Voltage (pu)	Read Only		T1(Low)
899						T1(High)
900			Motor Speed From Tach. (RPM)	Read Only		T1(Low)
901						T1(High)
902			Module 1 #1 Temperature ⁽⁹⁾	Read Only		T1(Low)
903						T1(High)
904			Module 1 #2 Temperature ⁽⁹⁾	Read Only		T1(Low)
905						T1(High)
906			Module 1 #3 Temperature ⁽⁹⁾	Read Only		T1(Low)
907						T1(High)
908			Module 1 #4 Temperature ⁽⁹⁾	Read Only		T1(Low)
909						T1(High)
910			Module 1 #5 Temperature ⁽⁹⁾	Read Only		T1(Low)
911						T1(High)
912			Module 1 #6 Temperature ⁽⁹⁾	Read Only		T1(Low)
913						T1(High)
914			Module 1 #7 Temperature ⁽⁹⁾	Read Only		T1(Low)
915						T1(High)
916			Module 1 #8 Temperature ⁽⁹⁾	Read Only		T1(Low)
917						T1(High)
918			Module 2 #1 Temperature ⁽⁹⁾	Read Only		T1(Low)
919						T1(High)
920			Module 2 #2 Temperature ⁽⁹⁾	Read Only		T1(Low)
921						T1(High)
922			Module 2 #3 Temperature ⁽⁹⁾	Read Only		T1(Low)
923						T1(High)
924			Module 2 #4 Temperature ⁽⁹⁾	Read Only		T1(Low)
925						T1(High)
926			Module 2 #5 Temperature ⁽⁹⁾	Read Only		T1(Low)
927						T1(High)
928			Module 2 #6 Temperature ⁽⁹⁾	Read Only		T1(Low)
929						T1(High)
930			Module 2 #7 Temperature ⁽⁹⁾	Read Only		T1(Low)
931						T1(High)
932			Module 2 #8 Temperature ⁽⁹⁾	Read Only		T1(Low)
933						T1(High)
934			Module 3 #1 Temperature ⁽⁹⁾	Read Only		T1(Low)
935						T1(High)
936			Module 3 #2 Temperature ⁽⁹⁾	Read Only		T1(Low)
937						T1(High)
938			Module 3 #3 Temperature ⁽⁹⁾	Read Only		T1(Low)
939						T1(High)
940			Module 3 #4 Temperature ⁽⁹⁾	Read Only		T1(Low)
941						T1(High)

MPS REGISTER (DECIMAL)	MODBUS REGISTER (DECIMAL)	A-B FILE (DECIMAL) (NOTE 4)	DESCRIPTION	ACCESS	RANGE	TYPE
942			Module 3 #5 Temperature ⁽⁹⁾	Read Only		T1(Low)
943						T1(High)
944			Module 3 #6 Temperature ⁽⁹⁾	Read Only		T1(Low)
945						T1(High)
946			Module 3 #7 Temperature ⁽⁹⁾	Read Only		T1(Low)
947						T1(High)
948			Module 3 #8 Temperature ⁽⁹⁾	Read Only		T1(Low)
949						T1(High)
950			Max Stator Temperature	Read Only		T1(Low)
951						T1(High)
952			Max Bearing Temperature	Read Only		T1(Low)
953						T1(High)
954			Max Load Temperature	Read Only		T1(Low)
955						T1(High)
956			Max Ambient Temperature	Read Only		T1(Low)
957						T1(High)
958			Min Stator Temperature	Read Only		T1(Low)
959						T1(High)
960			Min Bearing Temperature	Read Only		T1(Low)
961						T1(High)
962			Min Load Temperature	Read Only		T1(Low)
963						T1(High)
964			Min Ambient Temperature	Read Only		T1(Low)
965						T1(High)
966			Frequency (Hz)	Read Only		T1(Low)
967						T1(High)
968			I ² t Reset/Trip/Inhibit	Read Only		T1(Low)
969			Time (Minutes) ⁽⁷⁾			T1(High)
Event Records ⁽⁶⁾						
973	40974	7:0	Number of New Records	Read Only	0 - 65,535	T3
974			Record Head (Next Record)	Read Only	0 - 63	T3
975			Record Selector	R/W	0 - 63	T3
976			Record Date	Read Only		T23(Low)
977						T23(High)
978			Record Time	Read Only		T24(Low)
979						T24(High)
980			Record Type	Read Only		T26
981			Message Code	Read Only		T27
982			I _a ⁽¹⁾	Read Only		T1(Low)
983						T1(High)
984			I _b ⁽¹⁾	Read Only		T1(Low)
985						T1(High)
986			I _c ⁽¹⁾	Read Only		T1(Low)
987						T1(High)
988			I _g ⁽¹⁾	Read Only		T1(Low)
989						T1(High)

MPS REGISTER (DECIMAL)	MODBUS REGISTER (DECIMAL)	A-B FILE (DECIMAL) (NOTE 4)	DESCRIPTION	ACCESS	RANGE	TYPE
990			$V_{ab}^{(2)}$	Read Only		T1(Low)
991						T1(High)
992			$V_{bc}^{(2)}$	Read Only		T1(Low)
993						T1(High)
994			$V_{ca}^{(2)}$	Read Only		T1(Low)
995						T1(High)
996			Analog Input	Read Only		T1(Low)
997						T1(High)
998			Current Unbalance ⁽¹⁾	Read Only		T1(Low)
999						T1(High)
1000			Voltage Unbalance ⁽¹⁾	Read Only		T1(Low)
1001						T1(High)
1002			Start Time	Read Only		T3
1003			Used I ² t ⁽³⁾	Read Only		T1(Low)
1004						T1(High)
1005			Module 1 #1 Temperature ⁽⁹⁾	Read Only		T1(Low)
1006						T1(High)
1007			Module 1 #2 Temperature ⁽⁹⁾	Read Only		T1(Low)
1008						T1(High)
1009			Module 1 #3 Temperature ⁽⁹⁾	Read Only		T1(Low)
1010						T1(High)
1011			Module 1 #4 Temperature ⁽⁹⁾	Read Only		T1(Low)
1012						T1(High)
1013			Module 1 #5 Temperature ⁽⁹⁾	Read Only		T1(Low)
1014						T1(High)
1015			Module 1 #6 Temperature ⁽⁹⁾	Read Only		T1(Low)
1016						T1(High)
1017			Module 1 #7 Temperature ⁽⁹⁾	Read Only		T1(Low)
1018						T1(High)
1019			Module 1 #8 Temperature ⁽⁹⁾	Read Only		T1(Low)
1020						T1(High)
1021			Module 2 #1 Temperature ⁽⁹⁾	Read Only		T1(Low)
1022						T1(High)
1023			Module 2 #2 Temperature ⁽⁹⁾	Read Only		T1(Low)
1024						T1(High)
1025			Module 2 #3 Temperature ⁽⁹⁾	Read Only		T1(Low)
1026						T1(High)
1027			Module 2 #4 Temperature ⁽⁹⁾	Read Only		T1(Low)
1028						T1(High)
1029			Module 2 #5 Temperature ⁽⁹⁾	Read Only		T1(Low)
1030						T1(High)
1031			Module 2 #6 Temperature ⁽⁹⁾	Read Only		T1(Low)
1032						T1(High)

MPS REGISTER (DECIMAL)	MODBUS REGISTER (DECIMAL)	A-B FILE (DECIMAL) (NOTE 4)	DESCRIPTION	ACCESS	RANGE	TYPE
1033			Module 2 #7 Temperature ⁽⁹⁾	Read Only		T1(Low)
1034						T1(High)
1035			Module 2 #8 Temperature ⁽⁹⁾	Read Only		T1(Low)
1036						T1(High)
1037			Differential Current Phase A (A) ⁽⁶⁾	Read Only		T1(Low)
1038						T1(High)
1039			Differential Current Phase B (A) ⁽⁶⁾	Read Only		T1(Low)
1040						T1(High)
1041			Differential Current Phase C (A) ⁽⁶⁾	Read Only		T1(Low)
1042						T1(High)
1043			Reserved	Read Only		T1(Low)
1044						T1(High)
1045			Reserved	Read Only		T1(Low)
1046						T1(High)
1047			Reserved	Read Only		T1(Low)
1048						T1(High)
1049			Reserved	Read Only		T1(Low)
1050						T1(High)
1051			Reserved	Read Only		T1(Low)
1052						T1(High)
1053			Frequency	Read Only		T1(Low)
1054						T1(High)
1055			Power—S (kVA)	Read Only		T1(Low)
1056						T1(High)
1057			Power—P (kW)	Read Only		T1(Low)
1058						T1(High)
1059			Power—Q (kVAR)	Read Only		T1(Low)
1060						T1(High)
1061			Power Factor	Read Only		T1(Low)
1062						T1(High)
Underpower						
1070	41071	7:97	Trip Action	R/W	0 - 7	T42
1071			Trip Level	R/W	0.1 - 1.0	T1(Low)
1072						T1(High)
1073			Trip Delay	R/W	0.5 - 500 s	T1(Low)
1074						T1(High)
1075			Alarm Level	R/W	0.1 - 1.0	T1(Low)
1076						T1(High)
1077			Alarm Delay	R/W	10.5 - 500 s	T1(Low)
1078						T1(High)
1079			Alarm Action	R/W	0 - 7	T43
Reversepower						
1080	41081	7:107	Trip Action	R/W	0 - 7	T42
1081			Trip Level	R/W	0.1 - 1.0	T1(Low)
1082						T1(High)
1083			Trip Delay	R/W	0.5 - 500 s	T1(Low)

MPS REGISTER (DECIMAL)	MODBUS REGISTER (DECIMAL)	A-B FILE (DECIMAL) (NOTE 4)	DESCRIPTION	ACCESS	RANGE	TYPE
1084						T1(Low)
1085			Alarm Level	R/W	0.1 - 1.0	T1(High)
1086						T1(Low)
1087			Alarm Delay	R/W	10.5 - 500 s	T1(High)
1088						T1(Low)
1089			Alarm Action	R/W	0 - 7	T43
Status						
1096	41097	8:0	Trip and Alarm Summary	Read Only		T30
1097			Motor Status	Read Only		T28
1098			Starter Status	Read Only		T29
1099			Digital Inputs	Read Only		T35
1100			Relay Outputs	Read Only		T36
Message Stack						
1104	41105	8:8	Message 0	Read Only		T27
1105			Message 1	Read Only		T27
1106			Message 2	Read Only		T27
1107			Message 3	Read Only		T27
1108			Message 4	Read Only		T27
Trip Counters						
1130	41131	8:39	Overcurrent	Read Only		T3
1131			AUX Overcurrent	Read Only		T3
1132			Overload	Read Only		T3
1133			Earth Fault	Read Only		T3
1134			Current Unbalance	Read Only		T3
1135			Voltage Unbalance	Read Only		T3
1136			Jam	Read Only		T3
1137			Undercurrent	Read Only		T3
1138			Overvoltage	Read Only		T3
1139			Undervoltage	Read Only		T3
1140			Analog Input High	Read Only		T3
1141			Analog Input Low	Read Only		T3
1142			PTC	Read Only		T3
1143			Phase-Loss Current	Read Only		T3
1144			Phase-Reverse Current	Read Only		T3
1145			Phase-Loss Voltage	Read Only		T3
1146			Phase-Reverse Voltage	Read Only		T3
1147			Underspeed	Read Only		T3
1148			Contactors Status	Read Only		T3
1149			Digital 1 Trip	Read Only		T3
1150			Digital 2 Trip	Read Only		T3
1151			Digital 3 Trip	Read Only		T3
1152			Digital 4 Trip	Read Only		T3
1153			Digital 5 Trip	Read Only		T3
1154			Digital 6 Trip	Read Only		T3
1155			Digital 7 Trip	Read Only		T3
1156			RTD Module 1 #1	Read Only		T3
1157			RTD Module 1 #2	Read Only		T3

MPS REGISTER (DECIMAL)	MODBUS REGISTER (DECIMAL)	A-B FILE (DECIMAL) (NOTE 4)	DESCRIPTION	ACCESS	RANGE	TYPE
1158			RTD Module 1 #3	Read Only		T3
1159			RTD Module 1 #4	Read Only		T3
1160			RTD Module 1 #5	Read Only		T3
1161			RTD Module 1 #6	Read Only		T3
1162			RTD Module 1 #7	Read Only		T3
1163			RTD Module 1 #8	Read Only		T3
1164			RTD Module 2 #1	Read Only		T3
1165			RTD Module 2 #2	Read Only		T3
1166			RTD Module 2 #3	Read Only		T3
1167			RTD Module 2 #4	Read Only		T3
1168			RTD Module 2 #5	Read Only		T3
1169			RTD Module 2 #6	Read Only		T3
1170			RTD Module 2 #7	Read Only		T3
1171			RTD Module 2 #8	Read Only		T3
1172			RTD Module 3 #1	Read Only		T3
1173			RTD Module 3 #2	Read Only		T3
1174			RTD Module 3 #3	Read Only		T3
1175			RTD Module 3 #4	Read Only		T3
1176			RTD Module 3 #5	Read Only		T3
1177			RTD Module 3 #6	Read Only		T3
1178			RTD Module 3 #7	Read Only		T3
1179			RTD Module 3 #8	Read Only		T3
1180			RTD Module 1 Comm	Read Only		T3
1181			RTD Module 2 Comm	Read Only		T3
1182			RTD Module 3 Comm	Read Only		T3
1183			RTD Sensor	Read Only		T3
1184			Start Time Exceeded	Read Only		T3
1185			Display Comm	Read Only		T3
1186			Stop (In Protection Only)	Read Only		T3
1187			Lagging Power Factor – Q4	Read Only		T3
1188			Underfrequency	Read Only		T3
1189			Overfrequency	Read Only		T3
1190			A/D	Read Only		T3
1191			Network	Read Only		T3
1192			Leading Power Factor – Q3	Read Only		T3
1193			Starts Per Hour	Read Only		T3
1194			Differential Module Trip	Read Only		T3
1195			Differential Current Trip	Read Only		T3
1196			Reduced Overcurrent Trip	Read Only		T3
1197			Underpower Trip	Read Only		T3
1198			Reversepower Trip	Read Only		T3
Running Time						
1210	41211	9:0	Running Seconds	Read Only		T2(Low)
1211						T2(High)
Energy						
1212	41213	9:2	kW Seconds	Read Only		T4(Word 1)
1213						T4(Word 2)

MPS REGISTER (DECIMAL)	MODBUS REGISTER (DECIMAL)	A-B FILE (DECIMAL) (NOTE 4)	DESCRIPTION	ACCESS	RANGE	TYPE
1214						T4(Word 3)
1215						T4(Word 4)
1216			kVA Seconds	Read Only		T4(Word 1)
1217						T4(Word 2)
1218						T4(Word 3)
1219						T4(Word 4)
1220			kVAR Seconds	Read Only		T4(Word 1)
1221						T4(Word 2)
1222						T4(Word 3)
1223						T4(Word 4)
Differential Module Meter Values						
1224	41225	9:14	Differential Current Phase A (A)	Read Only		T1(Low)
1225						T1(High)
1226			Differential Current Phase B (A)	Read Only		T1(Low)
1227						T1(High)
1228			Differential Current Phase C (A)	Read Only		T1(Low)
1229						T1(High)
Underfrequency						
1230	41231	9:20	Trip Action	R/W	0 - 7	T42
1231			Trip Level	R/W	30 - 80 Hz	T1(Low)
1232						T1(High)
1233			Trip Delay	R/W	0.5 - 500 s	T1(Low)
1234						T1(High)
1235			Alarm Level	R/W	30 - 80 Hz	T1(Low)
1236						T1(High)
1237			Alarm Delay	R/W	0.5 - 500 s	T1(Low)
1238						T1(High)
Overfrequency						
1239	41240	9:29	Trip Action	R/W	0 - 7	T42
1240			Trip Level	R/W	30 - 80 Hz	T1(Low)
1241						T1(High)
1242			Trip Delay	R/W	0.5 - 500 s	T1(Low)
1243						T1(High)
1244			Alarm Level	R/W	30 - 80 Hz	T1(Low)
1245						T1(High)
1246			Alarm Delay	R/W	0.5 - 500 s	T1(Low)
1247						T1(High)
Underfrequency Alarm Action						
1248	41249	9:38	Alarm Action	R/W	0 - 7	T43
Overfrequency Alarm Action						
1249	41250	9:39	Alarm Action	R/W	0 - 7	T43
Power Factor Quadrant 3						
1250	41251	9:40	Trip Action	R/W	0 - 7	T42
1251			Trip Level	R/W	0.5 - 1.0	T1(Low)
1252						T1(High)
1253			Trip Delay	R/W	0.2 - 500 s	T1(Low)
1254						T1(High)

MPS REGISTER (DECIMAL)	MODBUS REGISTER (DECIMAL)	A-B FILE (DECIMAL) (NOTE 4)	DESCRIPTION	ACCESS	RANGE	TYPE
1255			Alarm Level	R/W	0.5 - 1.0	T1(Low)
1256						T1(High)
1257			Alarm Delay	R/W	0.2 - 500 s	T1(Low)
1258						T1(High)
1259			Alarm Action	R/W	0 - 7	T43
Starts Per Hour/Time Between Starts						
1267			Starts Remaining	Read Only	R0	T3
1268			Starts/Hour Time Remaining	Read Only	R0	T1(Low)
1269						T1(High)
1270	41271	9:60	Trip Action	R/W	0 - 7	T42
1271			Alarm Action	R/W	0 - 7	T43
1272			Starts per Hour Setting	R/W	0 - 9	T25
1273			Time Between Starts	R/W	0 - 500 m	T1(Low)
1274						T1(High)
Differential Module						
1277	41278	9:67	Module Enable	R/W	0 - 1	T6
1278			Module-Error Trip Action	R/W	0 - 7	T42
1279			Module-Error Alarm Action	R/W	0 - 7	T43
Differential Protection						
1280	41281	9:70	Trip Action	R/W	0 - 7	T42
1281			Trip Level	R/W	0.1 - 15 x I _d	T1(Low)
1282						T1(High)
1283			Trip Delay	R/W	0 - 10 s	T1(Low)
1284						T1(High)
1285			Alarm Level	R/W	0.1 - 15 x I _d	T1(Low)
1286						T1(High)
1287			Alarm Delay	R/W	0 - 10 s	T1(Low)
1288						T1(High)
1289			Alarm Action	R/W	0 - 7	T43
Ethernet						
1300	41301	9:90	IP Address	R/W		T22
1310			Address Mask	R/W		T22
1320			Default Gateway	R/W		T22
Waveform Capture⁽⁸⁾						
1330			Hardware Capable	R0	0 - 1	0 = Not Capable 1 = Capable
1331			Trace Auto-Start	RW	0 - 1	T6
1332			Sample Count	R0	0 - 4800	T3
1333			Channel Selector	RW	0 - 6	T107
1334			Sample Index	RW	0 - 4800	T3
1335			Trace Date	R0		T23 (Low)
1336						T23 (High)
1337			Trace Time	R0		T24(Low)
1338						T24 (High)
1339			Trace Trip Code	R0		T27
1340			Trace Memory	R0		T3
1341			Trace Memory	R0		T3

MPS REGISTER (DECIMAL)	MODBUS REGISTER (DECIMAL)	A-B FILE (DECIMAL) (NOTE 4)	DESCRIPTION	ACCESS	RANGE	TYPE
1342			Trace Memory	R0		T3
1343			Trace Memory	R0		T3
1344			Trace Memory	R0		T3
1345			Trace Memory	R0		T3
1346			Trace Memory	R0		T3
1347			Trace Memory	R0		T3
1348			Trace Memory	R0		T3
1349			Trace Memory	R0		T3
1350			Trace Memory	R0		T3
1351			Trace Memory	R0		T3
1352			Trace Memory	R0		T3
1353			Trace Memory	R0		T3
1354			Trace Memory	R0		T3
1355			Trace Memory	R0		T3
1356			Trace Memory	R0		T3
1357			Trace Memory	R0		T3
1358			Trace Memory	R0		T3
1359			Trace Memory	R0		T3
1360			Trace Memory	R0		T3
1361			Trace Memory	R0		T3
1362			Trace Memory	R0		T3
1363			Trace Memory	R0		T3
1364			Trace Memory	R0		T3
1365			Trace Memory	R0		T3
1366			Trace Memory	R0		T3
1367			Trace Memory	R0		T3
1368			Trace Memory	R0		T3
1369			Trace Memory	R0		T3
1370			Trace Memory	R0		T3
1371			Trace Memory	R0		T3
1372			Trace Memory	R0		T3
1373			Trace Memory	R0		T3
1374			Trace Memory	R0		T3
1375			Trace Memory	R0		T3
1376			Trace Memory	R0		T3
1377			Trace Memory	R0		T3
1378			Trace Memory	R0		T3
1379			Trace Memory	R0		T3
1380			Trace Memory	R0		T3
1381			Trace Memory	R0		T3
1382			Trace Memory	R0		T3
1383			Trace Memory	R0		T3
1384			Trace Memory	R0		T3
1385			Trace Memory	R0		T3
1386			Trace Memory	R0		T3
1387			Trace Memory	R0		T3

MPS REGISTER (DECIMAL)	MODBUS REGISTER (DECIMAL)	A-B FILE (DECIMAL) (NOTE 4)	DESCRIPTION	ACCESS	RANGE	TYPE
User Defined Registers						
1400	41401	9:190	User Register 0	R/W		T3
1401			User Register 1	R/W		T3
1402			User Register 2	R/W		T3
1403			User Register 3	R/W		T3
1404			User Register 4	R/W		T3
1405			User Register 5	R/W		T3
1406			User Register 6	R/W		T3
1407			User Register 7	R/W		T3
1408			User Register 8	R/W		T3
1409			User Register 9	R/W		T3
1410			User Register 10	R/W		T3
1411			User Register 11	R/W		T3
1412			User Register 12	R/W		T3
1413			User Register 13	R/W		T3
1414			User Register 14	R/W		T3
1415			User Register 15	R/W		T3
1416			User Register 16	R/W		T3
1417			User Register 17	R/W		T3
1418			User Register 18	R/W		T3
1419			User Register 19	R/W		T3
1420			User Register 20	R/W		T3
1421			User Register 21	R/W		T3
1422			User Register 22	R/W		T3
1423			User Register 23	R/W		T3
1424			User Register 24	R/W		T3
1425			User Register 25	R/W		T3
1426			User Register 26	R/W		T3
1427			User Register 27	R/W		T3
1428			User Register 28	R/W		T3
1429			User Register 29	R/W		T3
1430			User Register 30	R/W		T3
1431			User Register 31	R/W		T3
User Data						
1432	41433	9:222	User Register 0 Data	Read Only	<i>Range and Type defined by user register value.</i>	
1433			User Register 1 Data	Read Only		
1434			User Register 2 Data	Read Only		
1435			User Register 3 Data	Read Only		
1436			User Register 4 Data	Read Only		
1437			User Register 5 Data	Read Only		
1438			User Register 6 Data	Read Only		
1439			User Register 7 Data	Read Only		
1440			User Register 8 Data	Read Only		
1441			User Register 9 Data	Read Only		
1442			User Register 10 Data	Read Only		
1443			User Register 11 Data	Read Only		
1444			User Register 12 Data	Read Only		

MPS REGISTER (DECIMAL)	MODBUS REGISTER (DECIMAL)	A-B FILE (DECIMAL) (NOTE 4)	DESCRIPTION	ACCESS	RANGE	TYPE
1445			User Register 13 Data	Read Only		
1446			User Register 14 Data	Read Only		
1447			User Register 15 Data	Read Only		
1448			User Register 16 Data	Read Only		
1449			User Register 17 Data	Read Only		
1450			User Register 18 Data	Read Only		
1451			User Register 19 Data	Read Only		
1452			User Register 20 Data	Read Only		
1453			User Register 21 Data	Read Only		
1454			User Register 22 Data	Read Only		
1455			User Register 23 Data	Read Only		
1456			User Register 24 Data	Read Only		
1457			User Register 25 Data	Read Only		
1458			User Register 26 Data	Read Only		
1459			User Register 27 Data	Read Only		
1460			User Register 28 Data	Read Only		
1461			User Register 29 Data	Read Only		
1462			User Register 30 Data	Read Only		
1463	41464	9:253	User Register 31 Data	Read Only		

NOTES:

- (1) If the record type is START, these are the maximum values during the start.
- (2) If the record type is START, these are the minimum values during the start.
- (3) If the record type is START, this is the I^2t used during the start.
- (4) The A-B File is coded as FILE:ELEMENT. To read or write the element as floats, the PLC-5 or SLC 500 address would be <F><FILE>:<ELEMENT> (Example F9:222). To read or write the element as integers using PLC-5 Typed Read and Typed Write commands, add 20 to the file number and precede with N, <N><FILE+20>:<ELEMENT> (Example N29:222). File offset not required for SLC 500 Protected Typed Logical read and write commands.
- (5) Undefined registers in this table read zero. Registers greater than 1463 return error.
- (6) Starting with revision 2.3, differential-module data replaces RTD module 3 data. Applies only to event records.
- (7) If an overload trip occurred, reset time is indicated. If in an overload condition and not tripped, trip time is indicated. If a start inhibit is active, time to inhibit removal is indicated. All other conditions indicate 0.
- (8) Trace Data are 16-bit raw values. These formulas convert the Trace Data to real values based on relay settings. These are already applied in the COMTRADE files so additional conversions are not required.
 $I_a, I_b, I_c = \text{Trace Value} \times \text{CT Primary} \times 0.006285 \text{ A}$
 $I_o = \text{Trace Value} \times \text{EFCT Primary} \times 0.00408 \text{ A}$
1 PT: $V_{ab}, V_{bc}, V_{ca} = \text{Trace Value} \times (V_{\text{primary}}/V_{\text{secondary}}) \times 0.00042636 \text{ kV}$
{ V_{bc}, V_{ca} are phase-shifted values derived from V_{ab} }
2 PT: $V_{ab}, V_{bc}, V_{ca} = \text{Trace Value} \times (V_{\text{primary}}/V_{\text{secondary}}) \times 0.00042636 \text{ kV}$
{ V_{ca} is calculated from V_{ab} and V_{bc} }
3 PT: $V_{ab}, V_{bc}, V_{ca} = \text{Trace Value} \times (V_{\text{primary}}/V_{\text{secondary}}) \times 0.00043358 \text{ kV}$
{ V_{ab}, V_{bc}, V_{ca} are calculated from V_{an}, V_{bn}, V_{cn} }
- (9) The following MPS-RTD error codes are supported:
-100 = No RTD Sensor
-90 = Open Sensor
-80 = Shorted Sensor
-70 = No Data/Module Communication Error

APPENDIX F
REGISTER FORMATS

TYPE	C TYPE	DESCRIPTION
T1	Float	IEEE 32-Bit Floating-Point Number
		Bit 31: Sign
		Bits 30..23: Exponent
		Bits 22..0: Mantissa
		Float (High): Bits 31..16
		Float (Low): Bits 15..0
T2	Long	32-Bit Integer
		(High) Bits 31..16
		(Low) Bits 15..0
T3	Short	16-Bit Integer
T4	Double	IEEE 64-Bit Floating-Point Number
		Bit 63: Sign
		Bits 62..52: Exponent
		Bits 51..0: Mantissa
		Word 1 (Least Significant Word) ... Word 4 (Most Significant Word)
T5		Reserved
T6	Short	Enable/Disable
		0: Enabled
		1: Disabled
T9	Short	Voltage-Connection Type
		0: No Voltage Input
		1: 1PT
		2: 2PT
		3: 3PT and Direct Connection
T10	Short	Frequency
		0: 50 Hz
		1: 60 Hz
T11	Short	Starter Type
		0: Protection Only
		1: Full Voltage Non-Reversing
		2: Adjustable-Speed Drive
		3: Soft Start
		4: Full Voltage Reversing
		5: Two Speed
		6: Reactor/Resistor Closed Transition
		7: Reactor/Resistor Open Transition
		8: Slip Ring
		9: Soft Start with Bypass
		10: Part Winding
		11: Double Delta
		12: Autotransformer
		13: Two Winding
14: Wye Delta, Open Transition		
15: Wye Delta, Closed Transition		

TYPE	C TYPE	DESCRIPTION
T12	Short	Digital Input Function
		0: Input Not Used
		1: Start 1 (N.O. Contact)
		2: Start 2 (N.O. Contact)
		3: Stop (N.C. Contact)
		4: Starter RLYA Status
		5: Starter RLYB Status
		6: Starter RLYC Status
		7: Starter RLYD Status
		8: Interlock (N.C.)
		9: Trip1 (N.C.)
		10: Reset (N.O.)
		11: Local Select -
		12: Local Start1
		13: Local Start2
		14: 2-Wire Start1
		15: 2-Wire Start2
		16: FLA2 Select
		17: Limit1 Stop
		18: Limit2 Stop
		19: Reduced OC
20: Local Select +		
T13	Short	Relay Output Function
		0: None
		1: Starter RLYA
		2: Starter RLYB
		3: Starter RLYC
		4: Starter RLYD
		5: Trip1
		6: Alarm1
		7: Trip 2
		8: Interlock
		9: Local
		10: Current Detected
		11: Run Mode
		12: Starter Sequence Complete
		13: Thermal Lockout/Start Inhibit
		14: None
		15: Watchdog
		16: Trip3
		17: Alarm2
		18: Alarm3
		19: Trip1 Pulse
20: Reduced OC		
T14	Short	Relay Trip/Alarm Mode
		0: Fail Safe
		1: Non Fail Safe

TYPE	C TYPE	DESCRIPTION
T15	Short	Analog Output Function
		0: Phase Current
		1: Earth Leakage
		2: Thermal Capacity
		3: Stator RTD
		4: Bearing RTD
		5: Load RTD
		6: Ambient RTD
		7: Voltage
		8: Unbalance (I)
		9: Power Factor
		10: Real Power
		11: Reactive Power
		12: Apparent Power
		13: Zero
		14: Full Scale
		15: Speed
16: Differential Current		
T16	Short	Network Communication Type
		0: None (Disabled)
		1: A-B DF1
		2: Modbus RTU
		3: AnyBus
		4: DeviceNet
T17	Short	Network Baud Rate
		0: 1.2 kbit/s
		1: 2.4 kbit/s
		2: 4.8 kbit/s
		3: 9.6 kbit/s
		4: 19.2 kbit/s
		5: DeviceNet 125 kbit/s
		6: DeviceNet 250 kbit/s
7: DeviceNet 500 kbit/s		
T18	Short	Error Checking (AB DF1 Only)
		0: Not Selected
		1: CRC Check
T19	Short	Number of RTD Modules
		0: No RTD Module
		1: 1 RTD Module
		2: 2 RTD Modules
T20	Short	RTD Type
		0: Disable
		1: Platinum 100
		2: Nickel 100
		3: Nickel 120
4: Copper 10		

TYPE	C TYPE	DESCRIPTION
T21	Short	RTD Function
		0: Stator
		1: Bearing
		2: Load
		3: Ambient
		4: Stator Voting
		5: Bearing Voting
		6: Load Voting
T22	Char	20 ASCII characters
		Register +0: Char[0] and Char[1]. Char [0] at MSByte
		Register +1: Char[2] and Char[3]. Char [2] at MSByte
		Register +2: Char[4] and Char[5]. Char [4] at MSByte
		Register +3: Char[6] and Char[7]. Char [6] at MSByte
		Register +4: Char[8] and Char[9]. Char [8] at MSByte
		Register +5: Char[10] and Char[11]. Char [10] at MSByte
		Register +6: Char[12] and Char[13]. Char [12] at MSByte
		Register +7: Char[14] and Char[15]. Char [14] at MSByte
		Register +8: Char[16] and Char[17]. Char [16] at MSByte
		Register +9: Char[18] and Char[19]. Char [18] at MSByte
		A character value of 0 (NULL) will terminate the string and the following characters will be ignored.
		Ethernet address strings are of the form: “ddd.ddd.ddd.ddd”.
		The MAC address is a hex string of the form: “hhhhhhhhhhhh”.
		T23
Bits 31..16: Year in Binary		
Bits 15..8: 1-12 Months in Binary		
Bits 7..0: 1-31 days in Binary		
T24	Long	Time
		Bits 31..24: 0-23 Hours in Binary
		Bits 23..16: 0-60 Minutes in Binary
		Bits 15..8: 0-60 Seconds in Binary
T25	Short	Starts per Hour
		0: 1 Start per Hour
		1: 2 Starts per Hour
		2: 3 Starts per Hour
		3: 4 Starts per Hour
		4: 5 Starts per Hour
		5: 6 Starts per Hour
		6: 7 Starts per Hour
		7: 8 Starts per Hour
		8: 9 Starts per Hour
9: 10 Starts per Hour		

TYPE	C TYPE	DESCRIPTION
T26	Short	Trigger Source
		0: Empty Record
		1: Trip Record
		2: Start Record
		3: ETR Record
T27	Short	Message Code
		0: Main Overcurrent Trip
		1: Auxiliary Overcurrent Trip
		2: Overload Trip
		3: Overload Alarm
		4: Earth-Fault Trip
		5: Earth-Fault Alarm
		6: Current-Unbalance Trip
		7: Current-Unbalance Alarm
		8: Voltage-Unbalance Trip
		9: Voltage-Unbalance Alarm
		10: Jam Trip
		11: Jam Alarm
		12: Undercurrent Trip
		13: Undercurrent Alarm
		14: Overvoltage Trip
		15: Overvoltage Alarm
		16: Undervoltage Trip
		17: Undervoltage Alarm
		18: Analog-Input-High Trip
		19: Analog-Input-High Alarm
		20: Analog-Input-Low Trip
		21: Analog-Input-Low Alarm
		22: PTC Temperature Trip
		23: PTC Temperature Alarm
		24: Phase-Loss (Current) Trip
		25: Phase-Reverse (Current) Trip
		26: Phase-Loss (Voltage) Trip
		27: Phase-Reverse (Voltage) Trip
		28: Underspeed Trip
		29: Relay-Status Trip
		30: Digital 1 Trip
		31: Digital 2 Trip
		32: Digital 3 Trip
		33: Digital 4 Trip
		34: Digital 5 Trip
		35: Digital 6 Trip
		36: Digital 7 Trip
		37: RTD Module 1 INP 1 Trip
		38: RTD Module 1 INP 1 Alarm
		39: RTD Module 1 INP 2 Trip
40: RTD Module 1 INP 2 Alarm		

TYPE	C TYPE	DESCRIPTION
		41: RTD Module 1 INP 3 Trip
		42: RTD Module 1 INP 3 Alarm
		43: RTD Module 1 INP 4 Trip
		44: RTD Module 1 INP 4 Alarm
		45: RTD Module 1 INP 5 Trip
		46: RTD Module 1 INP 5 Alarm
		47: RTD Module 1 INP 6 Trip
		48: RTD Module 1 INP 6 Alarm
		49: RTD Module 1 INP 7 Trip
		50: RTD Module 1 INP 7 Alarm
		51: RTD Module 1 INP 8 Trip
		52: RTD Module 1 INP 8 Alarm
		53: RTD Module 2 INP 1 Trip
		54: RTD Module 2 INP 1 Alarm
		55: RTD Module 2 INP 2 Trip
		56: RTD Module 2 INP 2 Alarm
		57: RTD Module 2 INP 3 Trip
		58: RTD Module 2 INP 3 Alarm
		59: RTD Module 2 INP 4 Trip
		60: RTD Module 2 INP 4 Alarm
		61: RTD Module 2 INP 5 Trip
		62: RTD Module 2 INP 5 Alarm
		63: RTD Module 2 INP 6 Trip
		64: RTD Module 2 INP 6 Alarm
		65: RTD Module 2 INP 7 Trip
		66: RTD Module 2 INP 7 Alarm
		67: RTD Module 2 INP 8 Trip
		68: RTD Module 2 INP 8 Alarm
		69: RTD Module 3 INP 1 Trip
		70: RTD Module 3 INP 1 Alarm
		71: RTD Module 3 INP 2 Trip
		72: RTD Module 3 INP 2 Alarm
		73: RTD Module 3 INP 3 Trip
		74: RTD Module 3 INP 3 Alarm
		75: RTD Module 3 INP 4 Trip
		76: RTD Module 3 INP 4 Alarm
		77: RTD Module 3 INP 5 Trip
		78: RTD Module 3 INP 5 Alarm
		79: RTD Module 3 INP 6 Trip
		80: RTD Module 3 INP 6 Alarm
		81: RTD Module 3 INP 7 Trip
		82: RTD Module 3 INP 7 Alarm
		83: RTD Module 3 INP 8 Trip
		84: RTD Module 3 INP 8 Alarm
		85: RTD Module 1 Comm Trip
		86: RTD Module 1 Comm Alarm
		87: RTD Module 2 Comm Trip
		88: RTD Module 2 Comm Alarm

TYPE	C TYPE	DESCRIPTION
		89: RTD Module 3 Comm Trip
		90: RTD Module 3 Comm Alarm
		91: RTD Sensor-Failure Trip
		92: RTD Sensor-Failure Alarm
		93: Thermal Lockout
		94: All Defaults Loaded
		95: Non-Volatile Memory (NV) Enumeration Error
		96: NV Numeric Error
		97: NV String Error
		98: NV Event-Record Error
		99: NV Used Thermal Capacity Error
		100: Starter Trip
		101: Display Communications Trip
		102: Diagnostic Error
		103: Trip Caused By STOP
		104: Network-Communications Trip
		105: Network-Communications Alarm
		106: PF Quadrant 4 Trip
		107: PF Quadrant 4 Alarm
		108: Underfrequency Trip
		109: Underfrequency Alarm
		110: Overfrequency Trip
		111: Overfrequency Alarm
		112: PF Quadrant 3 Trip
		113: PF Quadrant 3 Alarm
		114: Phase-Reverse Alarm (Current)
		115: Phase-Reverse Alarm (Voltage)
		116: Starts per Hour Trip
		117: Starts per Hour Alarm
		118 to 127: Reserved
		128: Differential Communication Trip
		129: Differential Communication Alarm
		130: Differential Trip
		131: Differential Alarm
		132: Reduced Overcurrent Trip
		133: Underpower Trip
		134: Underpower Alarm
		135: Reversepower Trip
		136: Reversepower Alarm
		252: ETR Request ⁽²⁾
		253: Normal Start ⁽²⁾
		254: Incomplete Start ⁽²⁾
		255: No Trip or Alarm
T28	Short	Motor Status
		Bit0: 1 = Motor current > Current threshold
		Bit1: 1 = Motor in Run Mode
		Bit2: 1 = Motor at Full Speed (Based on Tach Information)

TYPE	C TYPE	DESCRIPTION
		Bit3: 1 = Motor Current > 125% FLA
		Bit4: 1 = Temperature Set Point Bypassed
		Bit5: 1 = Reduced Overcurrent Operational
T29	Short	Starter Sequencer Status
		1: Start1
		2: Run1
		3: Start2
		4: Run2
		5: Stop
		6: Backspin Timer On
T30	Short	Trip and Alarm Summary
		Bit0: 1 = Trip1 or Trip3
		Bit1: 1 = Alarm1, Alarm2, or Alarm3
		Bit2: 1 = Trip2
		Bit3: 1 = Interlocks Not Valid
		Bit4: 1 = $I^2t > I^2t$ Inhibit Level
		Bit5: 1 = Stops Active (STOP is Pressed)
T31	Char	RTC ASCII Character Setting String:
		Format: YY/MM/DD HH:mm:SS
		YY: 2-digit Year (Year 2000 - 2099)
		MM: Month 1-12
		DD: Day 1-31
		HH: Hour 0-23
		mm: Minute 0-59
		SS: Seconds 0-59
		RTC is updated when "Set RTC" command is issued.
T32	Short	Record_Head points to the next free record.
		Subtract 1 to obtain last record.
		Range is 0 to 63.
T33	Short	Thermal Model Type
		0: NEMA
		1: K-Factor
T34	Short	4-20 mA Analog Input Type
		0: Metering Only
		1: Generic 4-20 mA
		2: ASD Sync
		3: Motor Speed
T35	Short	Digital Input Status
		Bit0: 1 = Digital Input 1 Valid
		Bit1: 1 = Digital Input 2 Valid
		Bit2: 1 = Digital Input 3 Valid
		Bit3: 1 = Digital Input 4 Valid
		Bit4: 1 = Digital Input 5 Valid
		Bit5: 1 = Digital Input 6 Valid
		Bit6: 1 = Digital Input 7 Valid
T36	Short	Relay Output Status
		Bit0: 1 = Relay 1 Energized
		Bit1: 1 = Relay 2 Energized

TYPE	C TYPE	DESCRIPTION
		Bit2: 1 = Relay 3 Energized
		Bit3: 1 = Relay 4 Energized
		Bit4: 1 = Relay 5 Energized
T37	Short	MPS Command
		0: Stop
		1: Start 1
		2: Start 2
		3: Reset Trips
		4: Set Real-Time Clock
		5: Clear Data-Logging Records
		6: Clear Trip Counters
		7: Not Used
		8: Clear Running Hours
		9: Emergency Thermal Reset
		10: Select Local Control
		11: De-select Local Control
		12: Re-enable Temperature Protection
		13: Start Time
T38	Short	Overload Reset Type
		0: Normal
		1: Auto Reset
		2: Multiple-Motor Sequence
T39	Short	Language
		0: English
		1: Spanish (Not supported at this time.)
		2: French (Not supported at this time.)
T40	Short	Number of OPI's
		0: 1 OPI
		1: 2 OPI's
		2: 3 OPI's
T41	Short	Starter Transfer Type
		0: Time Transfer
		1: Current Transfer
T42	Short	Trip Action
		0: Disabled
		1: Trip1
		2: Trip2
		3: Trip3
		4: Trip1 & Trip2
		5: Trip1 & Trip3
		6: Trip1 & Trip2 & Trip3
		7: Trip2 & Trip3
T43	Short	Alarm Action
		0: Disabled
		1: Alarm1
		2: Alarm2
		3: Alarm3
		4: Alarm1 & Alarm2

TYPE	C TYPE	DESCRIPTION
		5: Alarm1 & Alarm3
		6: Alarm1 & Alarm2 & Alarm3
		7: Alarm2 & Alarm3
T82	Short	DeviceNet Producing Instance
		0: None
		1: 0x32 Basic Overload
		2: 0x33 Extended Overload
		3: 0x34 Basic Motor Starter
		4: 0x35 Extended Motor Starter 1
		5: 0x36 Extended Motor Starter 2
		6: 0x64 Status/Meters/RTDs
		7: 0x65 Status/Meters
		8: 0x66 Status
		9: User Registers
T83	Short	DeviceNet Consuming Instance
		0: None
		1: 0x02 Basic Overload
		2: 0x03 Basic Motor Starter
		3: 0x04 Extended Contactor
		4: 0x05 Extended Motor Starter
T107	Short	Trace Channel Selection
		0: I _a
		1: I _b
		2: I _c
		3: I ₀
		4: VA
		5: VB
		6: VC

NOTES:

- (1) All values are actual numbers unless indicated by “Bitx”.
- (2) Not a trip code. Used by event records to indicate a start record type.

APPENDIX G
MPS REVISION HISTORY

G.1 MPS-CTU REVISION HISTORY

MANUAL RELEASE DATE	MANUAL REVISION	HARDWARE REVISION⁽¹⁾ (REVISION NUMBER ON PRODUCT LABEL)	FIRMWARE REVISION
February 21, 2017	6-F-022117	02C	3.40
March 1, 2016	6-E-030116		
June 8, 2015	6-D-060815		3.30
January 15, 2015	6-C-011515	02C ⁽²⁾	3.21
June 19, 2014	6-B-061914	02C	3.20
February 14, 2014	6-A-101813	01J 02C	3.15
October 18, 2013		02B	
November 2012		02A	3.14
October 2012		02	3.13
January 2012		01H	3.11
April 2010			3.05
	3.04		
	3.03		
	3.02		
	3.01		
			3.00
			2.90
			2.80

⁽¹⁾ At time of release.

⁽²⁾ Hardware Update R also released.

MANUAL REVISION HISTORY

REVISION 6-F-022117

SECTION 9

UL certification updated.

REVISION 6-E-030116

SECTION 3

Section 3.2.1.2 updated.

SECTION 5

I_p Threshold setpoint added to Sections 5.8, 5.19, and 5.20.

SECTION 9

RCM Certification added.

APPENDIX A

System Config menu updated.

APPENDIX B

I_p Threshold setpoint added.

APPENDIX E

MPS registers 220 and 221 added.

REVISION 6-D-060815

SECTION 4

RTD protection updated in Section 4.4.

SECTION 5

Section 5.24 updated.

APPENDIX A

RTD temperature menu updated.

APPENDIX B

RTD modules updated.

APPENDIX E

MPS registers 548 and 549 added.

REVISION 6-C-011515

SECTION 2

Figs. 2.8, 2.9, 2.10, and 2.11 updated.

SECTION 5

OPI menu updated in Section 5.24.

REVISION 6-B-061914

SECTION 1

Underpower and reversepower features added.

SECTION 5

Underpower (5.17) and reversepower (5.18) sections added.

SECTION 9

Terminal torque specification added.

Direct connection (Note 5) updated in Section 9.4.

APPENDIX A

Underpower and reversepower trip and alarm access added to messages and protection menus.

APPENDIX B

Underpower and reversepower protection set points added.

APPENDIX E

Underpower and reversepower added to communication database table.

APPENDIX F

Underpower and reversepower added to register formats table.

REVISION 6-A-101813

SECTION 1

Faceplate updated.

Series 2 features added.

HARDWARE REVISION HISTORY

HARDWARE UPDATE R

Updated opto-coupler relay drive circuit.

Updated non-volatile and RTC battery.

Update R can only be combined with hardware revisions older than 01J and 02C. It will be indicated with an "Update R" label on the serial number label.

HARDWARE REVISION 02C

Updated opto-coupler relay drive circuit.

Updated non-volatile and RTC battery.

HARDWARE REVISION 02B

Power Supply: Power factor correction update.

Analog Module: ADC package changed.

HARDWARE REVISION 02A

Analog Module: Improved accuracy.

HARDWARE REVISION 02

Processor Module memory size increased.

Rev 02 required to enable waveform capture functionality.

HARDWARE REVISION 01J

Updated opto-coupler relay drive circuit.

Updated non-volatile and RTC battery.

HARDWARE REVISION 01H

Power supply updated.

FIRMWARE REVISION HISTORY

FIRMWARE REVISION 3.40

Added I_p Threshold setpoint.
Integrated I_p Threshold within current unbalance and power factor protective functions.

FIRMWARE REVISION 3.30

Added RTD Temperature Trip Action, Alarm Action, and ability to meter temperature information.

FIRMWARE REVISION 3.21

Underspeed protection can now be enabled after a motor start.

FIRMWARE REVISION 3.20

Underpower and Reversepower protection added.
Loss of network comms time increased to 10 s.
RTD temperature trip now occurs when temperature is equal to or greater.

FIRMWARE REVISION 3.15

HMC Compensation limit is set to 0.9 (90%).
Added feature to initiate MPS upgrade mode using OPI.

FIRMWARE REVISION 3.14

Fixed RTD reading for unused RTDs.

FIRMWARE REVISION 3.13

Fixed EtherNet/IP issue with Exp Msg.

FIRMWARE REVISION 3.11

Waveform capture added and RTD voting added.

FIRMWARE REVISION 3.05

DeviceNet I/O Assembly Tx queue size increased to prevent loss of data (only an issue with Assembly 0x64).

FIRMWARE REVISION 3.04

Added Default Gateway to Ethernet settings group.

FIRMWARE REVISION 3.03

Corrected OPI flashing problem.

FIRMWARE REVISION 3.02

Added delay in EtherNet/IP communications to improve performance during high-bandwidth communication.

FIRMWARE REVISION 3.01

Added Starts Remaining to communications.
Added Time Remaining until Start Inhibit Removal to communications.

FIRMWARE REVISION 3.00

Added Starts Remaining to meter values.
Added Time Remaining until a start is available to the meter values.

FIRMWARE REVISION 2.90

Added analog-output filter.

FIRMWARE REVISION 2.80

Added digital input selection "Local Select +".
Added OPI start-source selection to LOCAL mode.
Increased tach gear-tooth number to 120.

G.2 MPS-OPI REVISION HISTORY

MANUAL RELEASE DATE	MANUAL REVISION	HARDWARE REVISION (REVISION NUMBER ON PRODUCT LABEL)	FIRMWARE REVISION
January 15, 2015	6-C-011515	03A	1.60
June 19, 2014	6-B-061914		
October 18, 2013	6-A-101813		
May 2007			

HARDWARE REVISION HISTORY

HARDWARE REVISION 03A

Display update.

FIRMWARE REVISION HISTORY

FIRMWARE REVISION 1.60

Firmware update to support new display and equivalent LCD version.

G.3 MPS-RTD REVISION HISTORY

MANUAL RELEASE DATE	MANUAL REVISION	PRODUCT REVISION (REVISION NUMBER ON PRODUCT LABEL)
January 15, 2015	6-C-011515	02
June 19, 2014	6-B-061914	
October 18, 2013	6-A-101813	
December 2006		

PRODUCT REVISION HISTORY

PRODUCT REVISION 02

New analog PWB and power supply PWB. Increased accuracy. Wider input voltage range.

G.4 MPS-DIF REVISION HISTORY

MANUAL RELEASE DATE	MANUAL REVISION	PRODUCT REVISION (REVISION NUMBER ON PRODUCT LABEL)
January 15, 2015	6-C-011515	01
June 19, 2014	6-B-061914	
October 18, 2013	6-A-101813	
November 2007		

PRODUCT REVISION HISTORY

PRODUCT REVISION 01

Initial Release.