

| REV. | DESCRIPTION | DATE | DESIGNED | APPROVED |
|------|--------------------------------|------------|-----------|----------|
| A | First issue of outline drawing | 09/10/2019 | Dal Molin | Tinto |

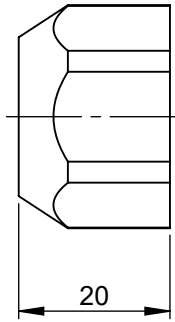

REFERENCE 1

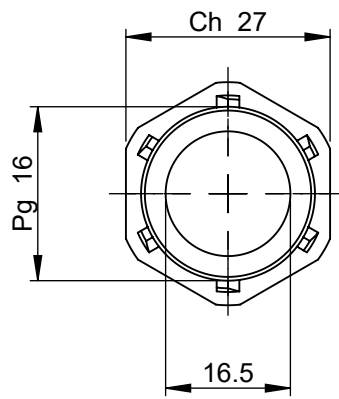
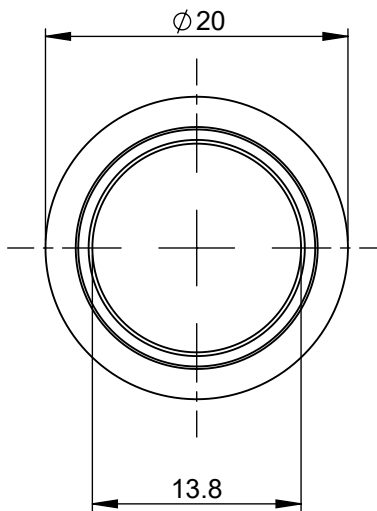
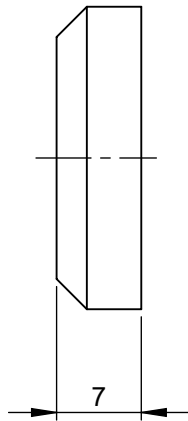

REFERENCE 2

| 2 | Seal | / | Rubber CR |
|------|-------------|------|--------------------|
| 1 | Nut Pg 16 | / | Polyamide 6-15% GF |
| REF. | DESIGNATION | Q.TY | MATERIAL |

SAP drawing number

| | | |
|---|--|----------------------------------|
| DIMENSIONS AND TOLERANCES IN MILLIMETERS, DEFINED ACCORDING TO ISO 1101-2017. | | |
| ● | FIT/ FUNCTION CRITICAL CHARACTERISTICS SYMBOL | |
| <S> | SAFETY/ COMPLIANCE CRITICAL CHARACTERISTICS SYMBOL | |
| CPK | DENOTES CPK DIMENSIONS MINIMUM CPK VALUE | |
| ST | DENOTES A CHARACTERISTIC THAT PROVIDES AN INDICATION OF PROCESS PERFORMANCE.PROCEDURE FOR MEASUREMENTAND TRACKINGTO BE DEFINED IN LITTELFUSE INSPECTION INSTRUCTIONS | |
| CP | DENOTES CP DIMENSIONS, -MINIMUM CP VALUE MUST BE WITHIN THE DIMENSIONAL LIMITATIONS SHOWN ON DRAWING AND INITIALLY LOCATED TO ALLOW FOR MAXIMUM TOOL LIFE | |
| TOLERANCES UNLESS OTHERWISE SPECIFIED | | |
| ONE PLACE DECIMAL ± 0.5 | | THREE PLACES DECIMAL ± 0.100 |
| TWO PLACES DECIMAL ± 0.20 | | ANGULAR $\pm 2^\circ$ |
| NAME | DATE | |
| DRAWN L. Dal Molin | 10/9/2019 | |
| CHECKED - | - | |
| - | - | |
| - | - | |
| FORM NO: CVP-PE40-0014 REV A | | |
| FIRST ANGLE PROJECTION | | |
| | | |
| | | |
| TITLE | | |
| NUT AND SEAL FOR $\varnothing 16$ | | |
| CORRUGATED TUBE | | |
| SIZE: A4 | DWG. NO. OL-00601100 | REV. A |
| DO NOT SCALE DRAWING | | |
| SCALE 1:1 | SHEET 1 OF 1 | |

THIS DRAWING AND THE INFORMATION CONTAINED WITHIN IT ARE CONFIDENTIAL AND MAY NOT BE COPIED OR DISCLOSED WITHOUT THE WRITTEN PERMISSION OF LITTELFUSE.