

DOVETAIL FEATURES USED TO INTERLOCK MULTIPLE HOLDERS

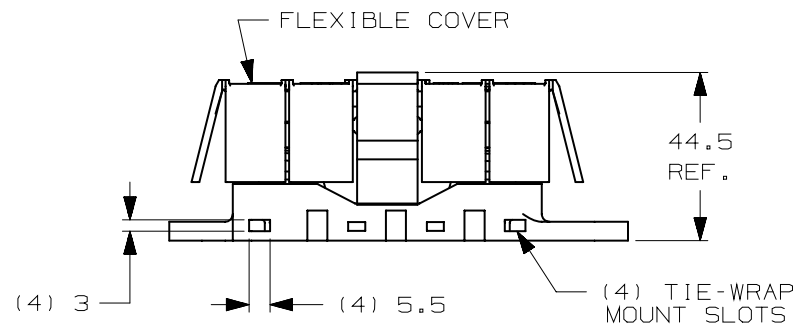

PART NO.	DESCRIPTION	MATERIAL (STUDS & HARDWARE)
02981028HXFCB	BASE ONLY (NO HARDWARE)	ZINC-PLATED STEEL
02981028HXFCC	COVER ONLY	-
02981028HXFC	ASSEMBLY	ZINC-PLATED STEEL
02981028HXFC-SS	ASSEMBLY	STAINLESS STEEL

NOTES:

- 1) BASE: UL94V-0 GLASS-FILLED PPA
M8 STUDS: SEE CHART
HEX NUTS & SPLIT WASHERS: SEE CHART
COVER: UL94V-0 ELASTOMER
- 2) MAX FUSE RATING: 500A
- 3) M8 STUD TORQUE: 12-18Nm
MOUNTING TORQUE (W/M6 BOLTS & WASHERS): 5Nm
- 4) TEMPERATURE RATING: -40°C TO 125°C
- 5) WIRE SIZE: 8mm² TO 30mm²

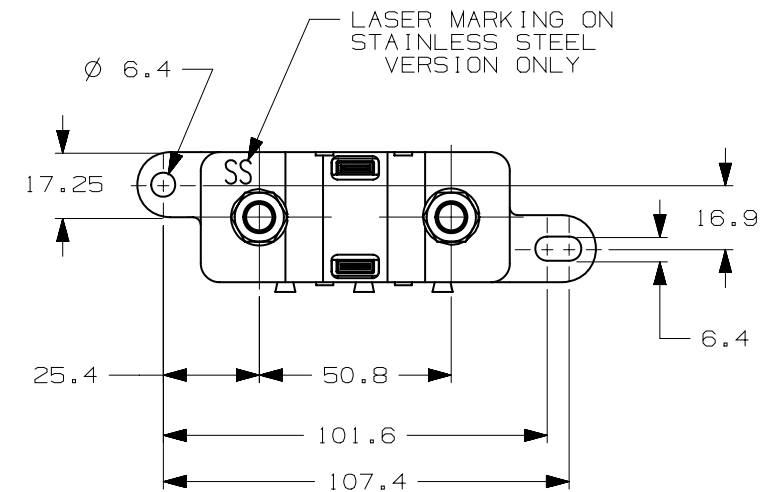

LASER MARKING ON STAINLESS STEEL VERSION ONLY

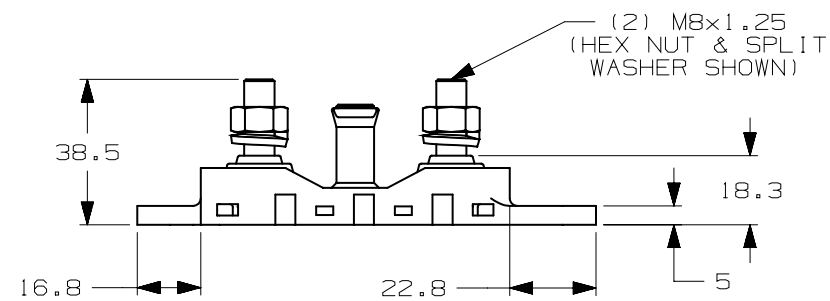

(2) M8x1.25 (HEX NUT & SPLIT WASHER SHOWN)

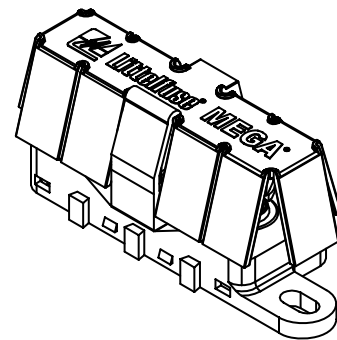

METRIC

NO	COMPONENT NO	DESCRIPTION	QTY/M	U/M
BILL OF MATERIAL				
UNLESS OTHERWISE SPECIFIED, DIMENSIONS ARE IN MILLIMETERS. DIMENSIONS IN BRACKETS [] ARE INCHES				
UNLESS OTHERWISE SPECIFIED, DIMENSIONS DO NOT INCLUDE PLATING.				
⊙	DENOTES CRITICAL CHARACTERISTICS.			
CPK	DENOTES CPK DIMENSIONS, -MINIMUM CPK VALUE			
ST	DENOTES A CHARACTERISTIC THAT PROVIDES AN INDICATION OF PROCESS PERFORMANCE. PROCEDURE FOR MEASUREMENT AND TRACKING TO BE DEFINED IN LITTELFUSE INSPECTION INSTRUCTIONS			
CP	DENOTES CP DIMENSIONS, -MINIMUM CP VALUE MUST BE WITHIN THE DIMENSIONAL LIMITATIONS SHOWN ON DRAWING AND INITIALLY LOCATED TO ALLOW FOR MAXIMUM TOOL LIFE			

COPIES TO	MATL SPEC	FINISH	SCALE	DRW DATE	CHK DATE	APPD DATE	TOLERANCES UNLESS OTHERWISE SPECIFIED (REF. ISO 2768-mK)	TITLE
1 9 2 10 3 12 4 13 5 14 6 15 7 16 8 17		N/A	1:2	04/30/09			UP TO 0.5 UP TO 3 UP TO 6 UP TO 30 UP TO 120 OVER 30 - 400 ±0.1 ±0.2 ±0.3 ±0.5	FLEX-MEGA FUSE HOLDER
18 19 20 21 23 33 43 53	SEE NOTES							

LTR	DATE	REVISION	CHK	APD
A	04/30/09	000689ER - RELEASE	KH	
B	7/08/09	00119BEC-ADDED 02981028HXFC-SS, 02981028HXFCB, & 02981028HXFC GMB		
C	09/10/09	001265EC-36.8 WAS 37.0, 17.25 WAS 17.2, (4)3 WAS (2)3, (4)5.5 WAS (2)5.5, ADDED LASER MARKING, CHG TOL. BLK TO 150 2768-mK GMB		
D	02/11/11	501732ECA-CHANGE BOLT DESIGN ON BASE.	OPL	

REVISION DRWG. NO. OL-02981028HXFC

