

PART NUMBER	COVER "A" OPENING POSITION	COVER "B" OPENING POSITION	FLANGED NUT LOCATION	TORQUE LOCATION NOTE 2	"NO TORQUE" LOCATION NOTE 4	FUSE RATING IN LOCATION "A"	FUSE RATING IN LOCATION "B"
02982011ZXT	C E F	B C E	3	-	3	450 A	350 A

LTR	DATE	REVISION	CHK	APD
A	02/04/11	504650ERA-RELEASED	OPL	
B	06/08/12	505199ECA-CORRECTION OF NOTES NUMBERS ACCORDING TO GENERAL NOTES	OPL	
C	03/21/14	510289ECA-IN CHART REMOVE: FLANGED NUT LOCATION 2, NO. TORQUE LOCATION 2, IN DRAWING REMOVE NUT.	OPL	

BOLD NUMBER DESIGNATION REFERS TO NUT & TORQUE LOCATION (SEE CHART)

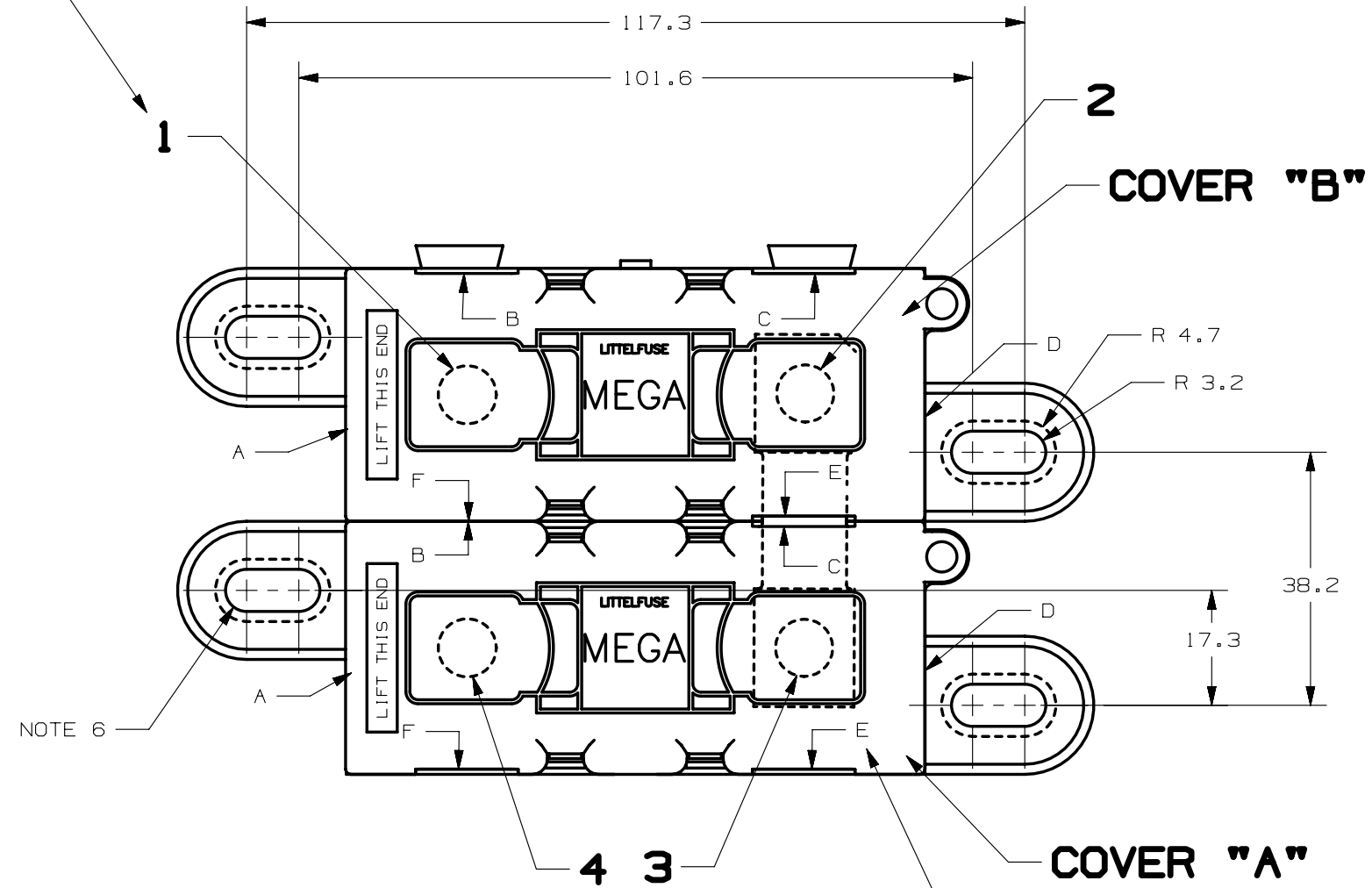

LETTER DESIGNATIONS REFER TO POSITIONS OF AVAILABLE COVER OPENINGS. (SEE CHART)

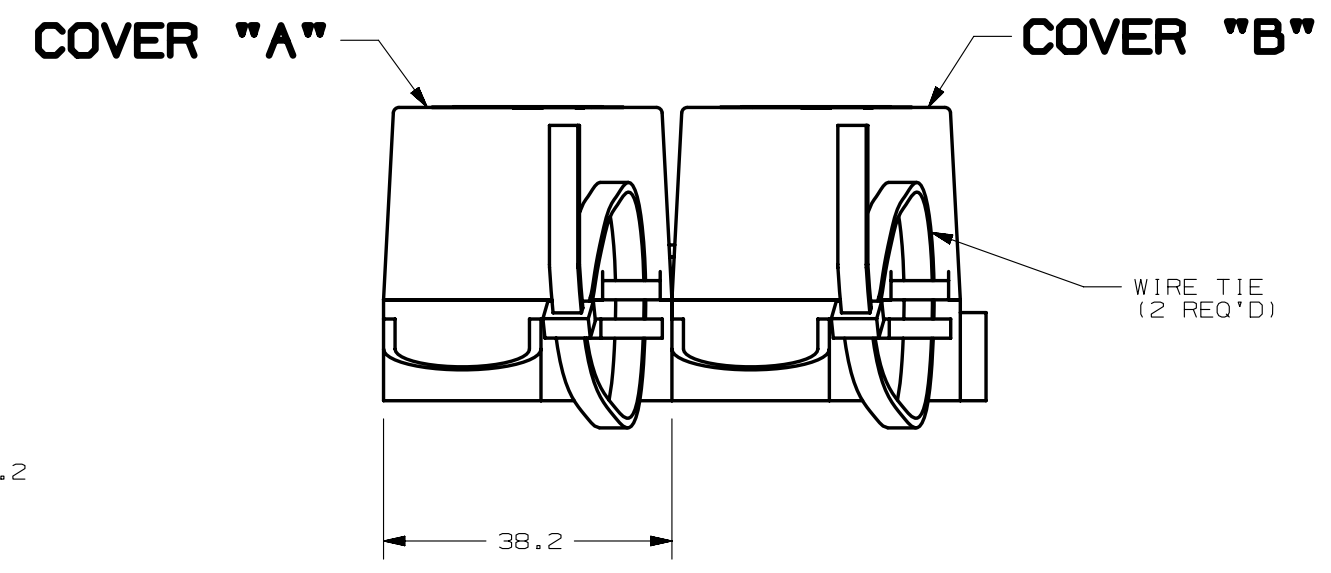
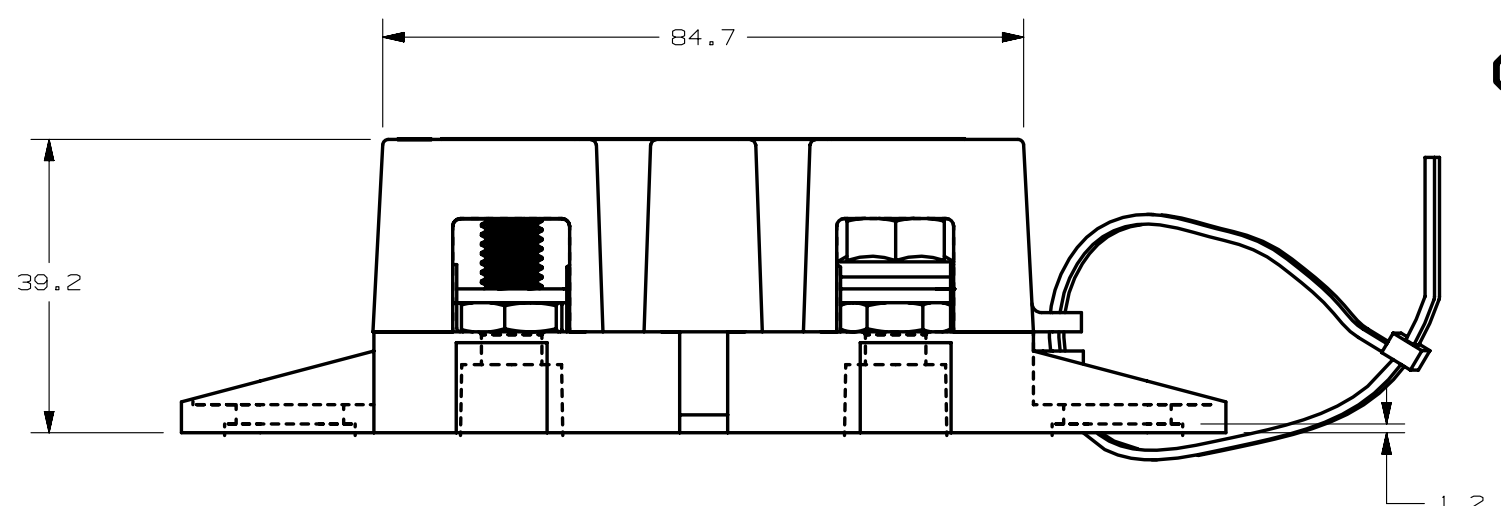
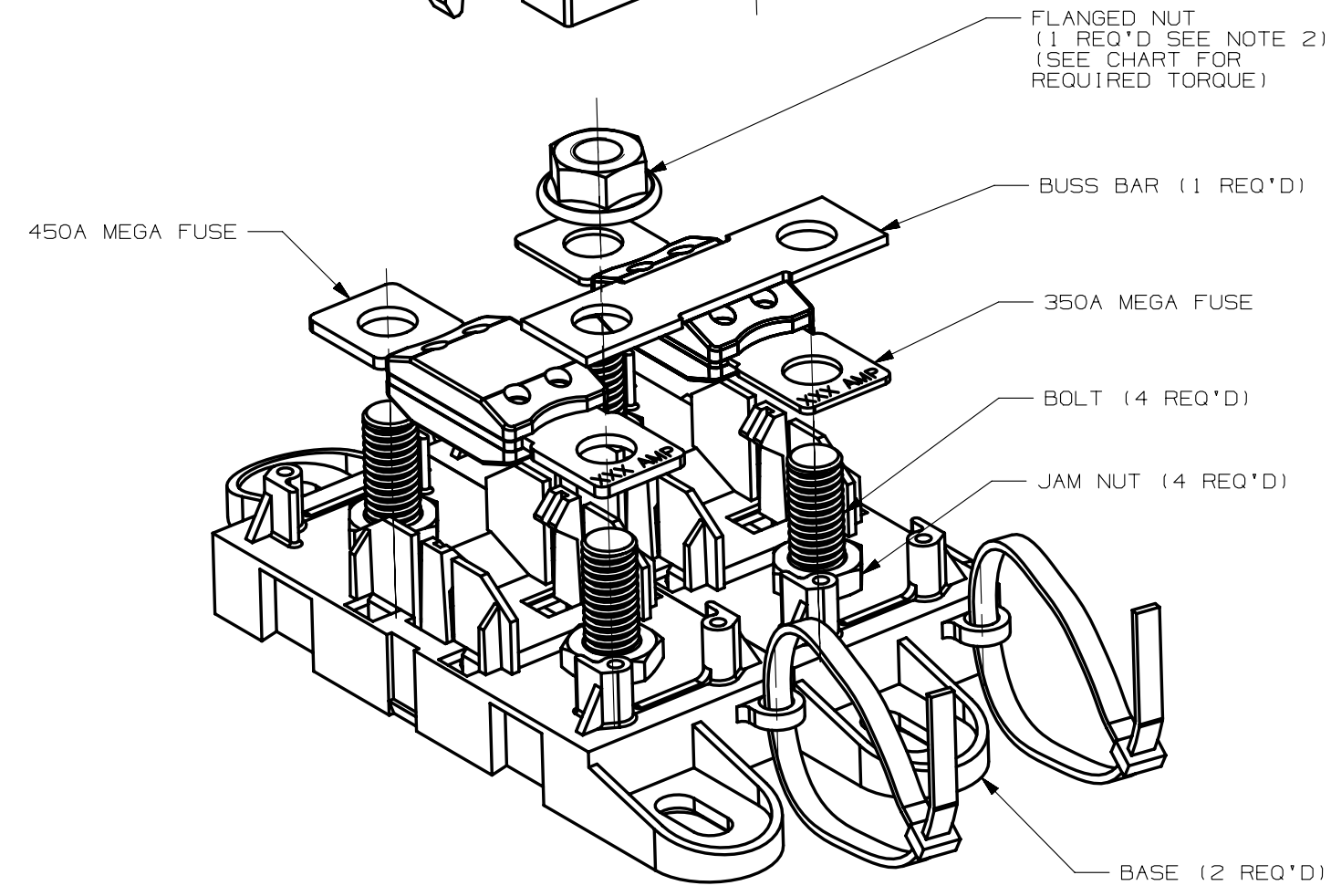
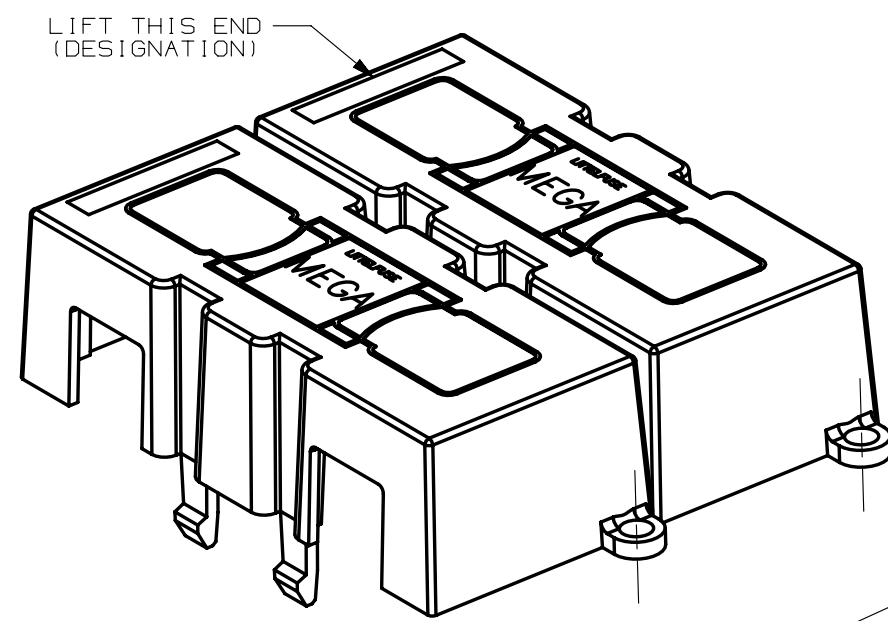

GENERAL NOTES:

- COVER RETENTION TEST: MINIMUM FORCE OF 2 LBS. IS REQUIRED TO REMOVE COVER WHEN IT IS SUSPENDED UPSIDE DOWN. FORCE SHALL BE APPLIED THROUGH THE INNER HOLES (2) IN BASE. USE FIXTURE #T-C403 TO SUPPORT PART.
- TORQUE APPLIED AS INDICATED IN CHART TORQUE REQUIREMENTS FOR THE HEX NUT USED TO SECURE THE BUSSBAR OR THE CUSTOMER RING TERMINAL TO THE MEGA FUSE TO BE:
8mm NUT - 12-18 NEWTON METERS (106-159 IN-LBS)
- L/F VALIDATION TEST SPEC. VS-005005.
- MANUALLY ASSEMBLE FLANGED NUT ONTO STUD AND FINGER TIGHTEN ANYWHERE BELOW TOP OF STUD, FOR ALL "NO TORQUE" LOCATIONS

5. MATERIALS:

- * BODY - GLASS FILLED THERMOPLASTIC
COLOR - BLACK
 - * COVER - THERMOPLASTIC
COLOR - BLACK
 - * WIRE TIE - THERMOPLASTIC
COLOR - BLACK
 - * STUDS & NUTS - M8 X 1.25 STEEL
ZINC PLATE WITH TRIVALENT CHROMATE, LEACHED AND SEALED,
INTEGRAL TORQUE CONTROL LUBRICANT FINISH
(MEETS 96 HR. ASTM STD. B-117 SALT SPRAY REQ.)
6. MOUNT FUSE HOLDER AT THE LOCATIONS SHOWN USING M6 STUDS AND MATING FLANGE NUTS. TORQUE NUTS TO 4.1±0.7Nm.

NO	COMPONENT NO	DESCRIPTION	QTY/M	U/M
BILL OF MATERIAL				
UNLESS OTHERWISE SPECIFIED, DIMENSIONS ARE IN MILLIMETERS. DIMENSIONS IN BRACKETS [] ARE INCHES				
UNLESS OTHERWISE SPECIFIED, DIMENSIONS DO NOT INCLUDE PLATING.				
⊙	DENOTES CRITICAL CHARACTERISTICS.			
CPK	DENOTES CPK DIMENSIONS, -MINIMUM CPK VALUE			
ST	DENOTES A CHARACTERISTIC THAT PROVIDES AN INDICATION OF PROCESS PERFORMANCE. PROCEDURE FOR MEASUREMENT AND TRACKING TO BE DEFINED IN LITTELFUSE INSPECTION INSTRUCTIONS			
CP	DENOTES CP DIMENSIONS, -MINIMUM CP VALUE MUST BE WITHIN THE DIMENSIONAL LIMITATIONS SHOWN ON DRAWING AND INITIALLY LOCATED TO ALLOW FOR MAXIMUM TOOL LIFE			
COPIES TO		MATL SPEC		
1	9	18		
2	10	19		
3	12	20		
4	13	21	DRW	OPL
5	14	23	DATE	04/03/12
6	15	33	SCALE	1:1
7	16	43	CHK	DATE
8	17	53	APPD	DATE
FINISH				
FINSH GOOD WT				
GRAMS/PIECE				
TOLERANCES UNLESS OTHERWISE SPECIFIED (REF. ISO 2768-MH)				
DIMENSION	0.5 - .3"	.3 - .6"	.6 - .30"	.30 - .120"
TOLERANCE	+0.05	+0.05	+0.1	+0.15
3RD ANGLE PROJECTION				
TITLE				
DUAL MEGAFUSE HOLDER				
Littelfuse		REVISION	DRWG. NO.	OUTLINE
CHICAGO, USA 773-628-1000		C	02982011ZXT	



CAD GENERATED DRAWING - NO PENCIL CHANGES ALLOWED (REV C)