

COVER PART	COVER OPENING POSITION
A	C F
B	A C D E
C	B E

LTR	DATE	REVISION	CHK	APD
A	07/18/06	61864 - RELEASED	DJG	
B	04/10/07	85414D-REDRAWN IN UG	GMB	
C	08/31/07	000170EC/C - REMOVE USA FROM COVER	BRK	
D	04/24/08	000463EC/D-CHG. NOTE 2	GMB	

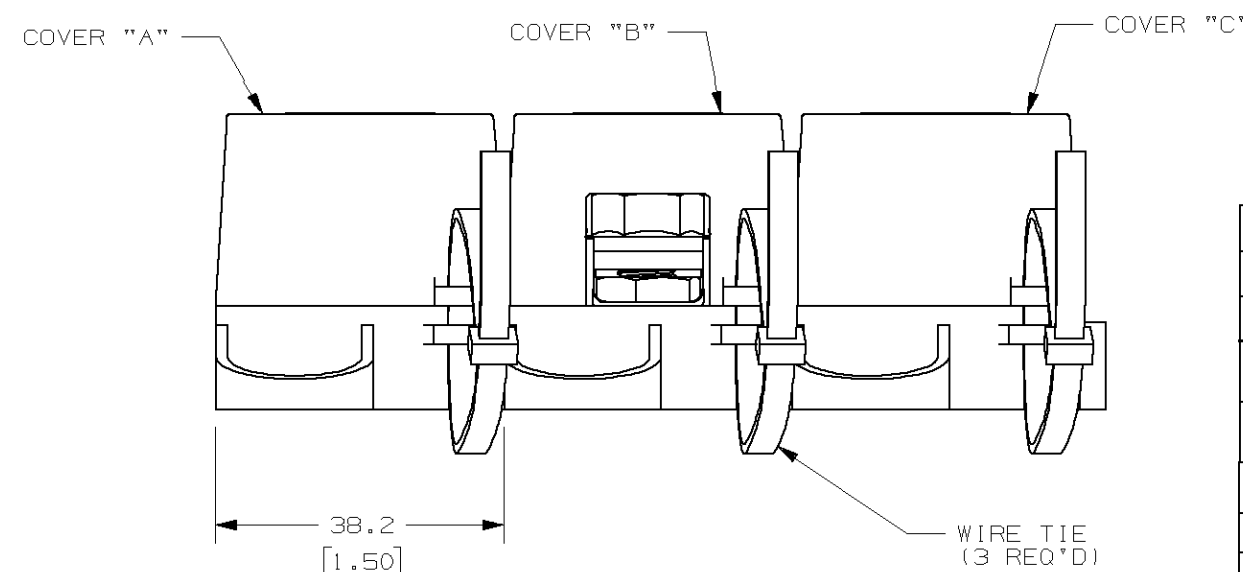
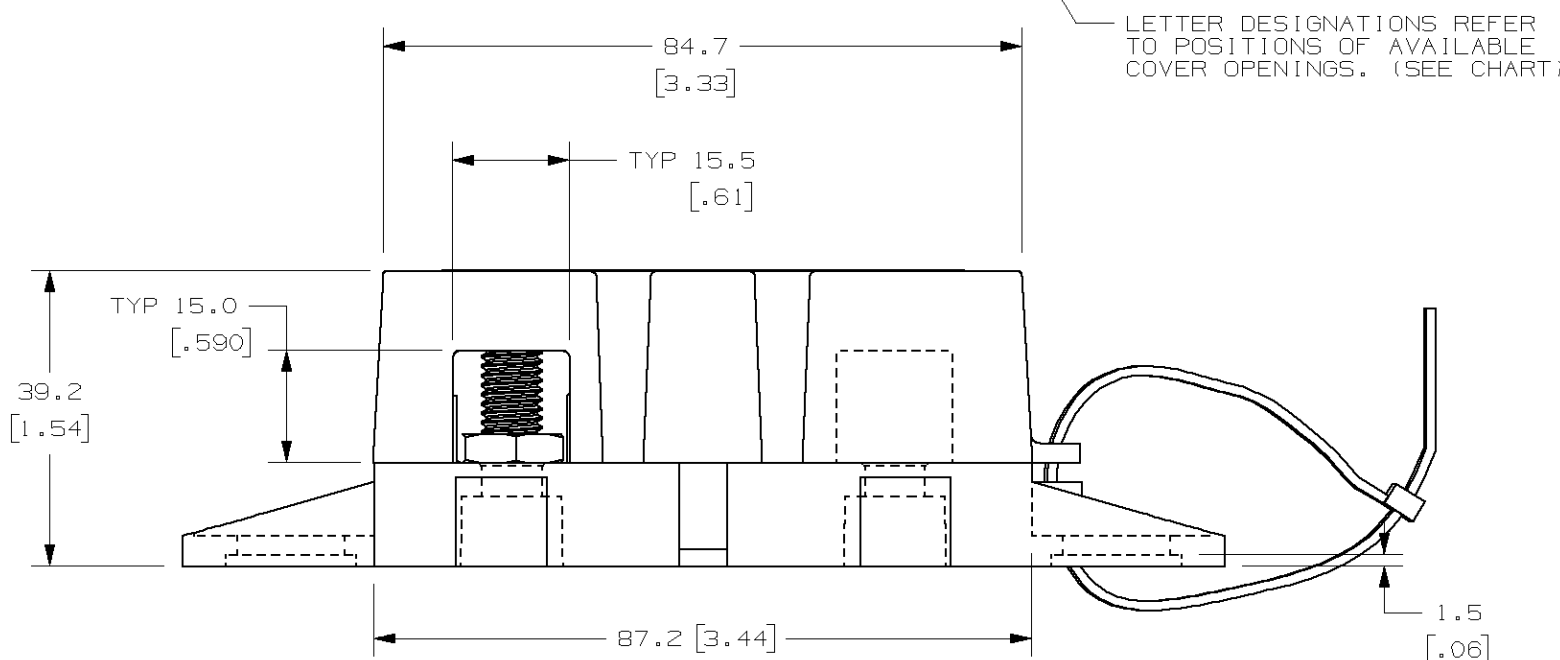
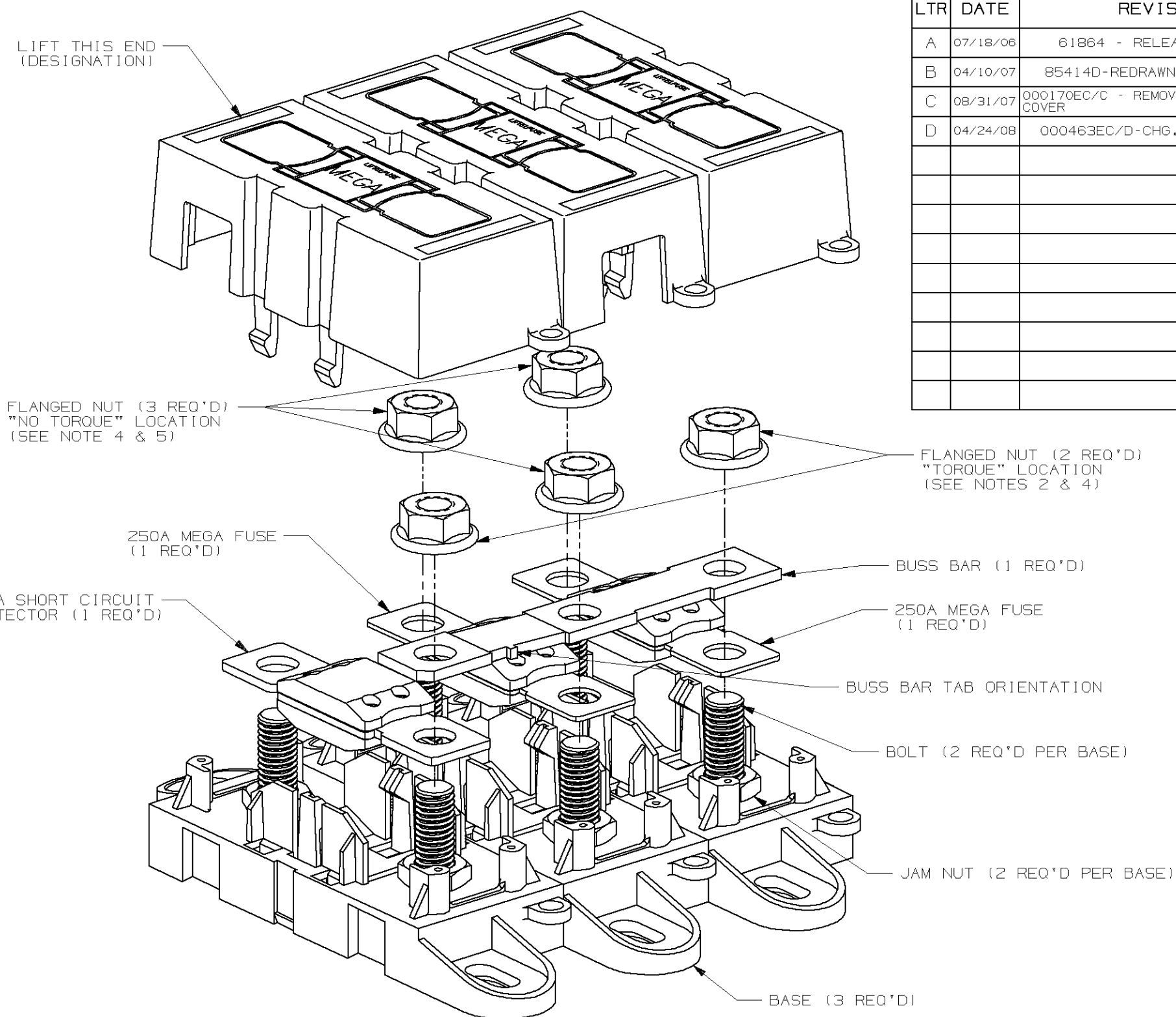
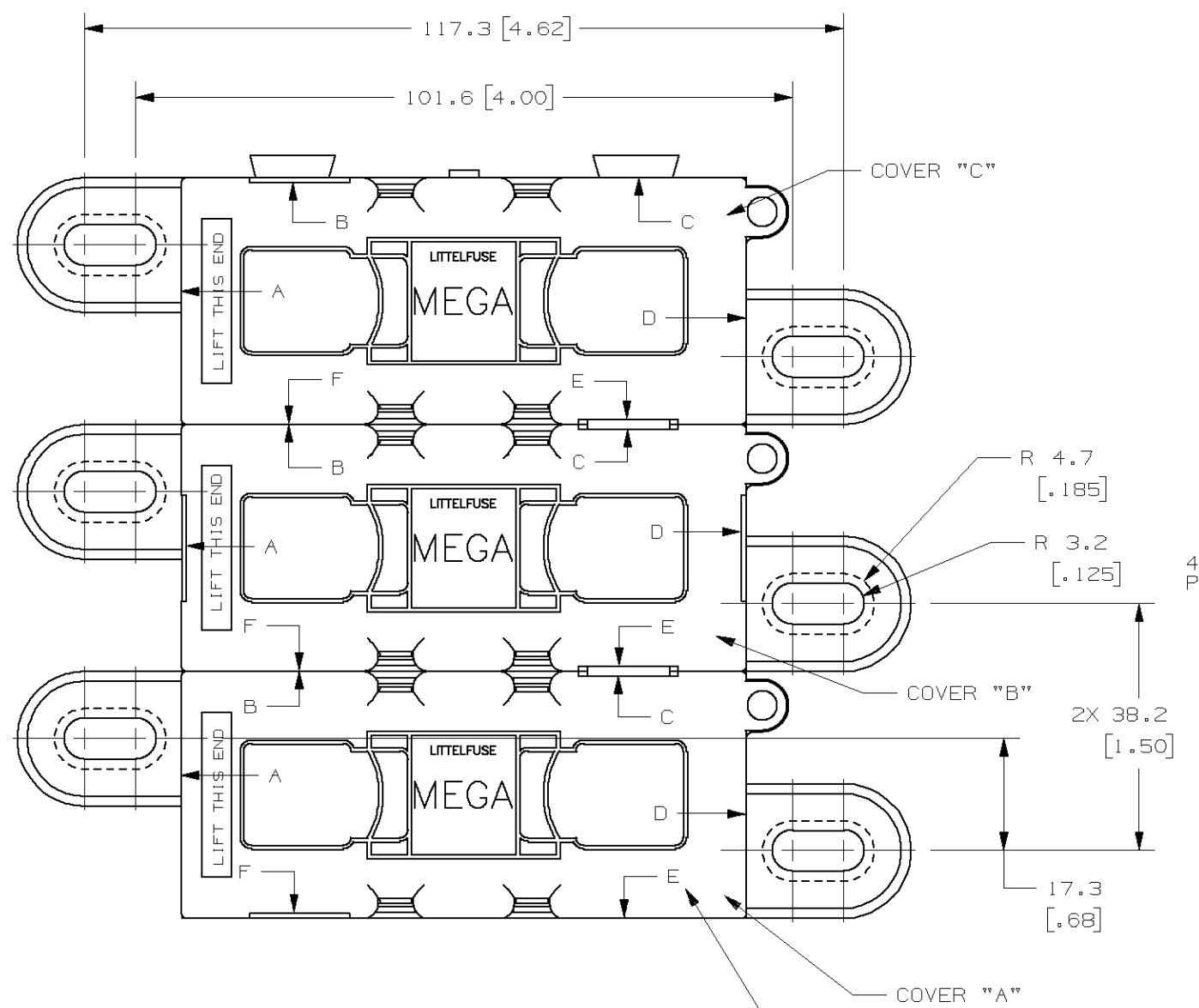

GENERAL NOTES:

- COVER RETENTION TEST: MINIMUM FORCE OF 2 LBS. IS REQUIRED TO REMOVE COVER WHEN IT IS SUSPENDED UPSIDE DOWN. FORCE SHALL BE APPLIED THROUGH THE INNER HOLES (2) IN BASE. USE FIXTURE #T-C403 TO SUPPORT PART.
- TORQUE APPLIED TO ALL "TORQUE" LOCATIONS TORQUE REQUIREMENTS FOR THE HEX NUT USED TO SECURE THE BUSSBAR OR THE CUSTOMER RING TERMINAL TO THE MEGA FUSE TO BE:
8mm NUT - 12-18 NEWTON METERS [106-159 IN-LBS]
- HOLDER MEETS L/F VALIDATION TEST SPEC. VS-005005.
- FLANGED NUT TO MEET THE FOLLOWING CRITERIA:
FORD PART NO. W520413
FINISH: S437.
- MANUALLY ASSEMBLE FLANGED NUT ONTO STUD AND FINGER TIGHTEN ANYWHERE BELOW TOP OF STUD, FOR ALL "NO TORQUE" LOCATIONS.

6. MATERIALS:

- * BODY - GLASS FILLED THERMOPLASTIC
COLOR - BLACK
- * COVER - THERMOPLASTIC
COLOR - BLACK
- * WIRE TIE - THERMOPLASTIC
COLOR - BLACK
- * STUDS & NUTS - M8 X 1.25 STEEL ZINC PLATED WITH TRIVALENT CHROMATE, LEACHED AND SEALED, INTEGRAL TORQUE CONTROL LUBRICANT FINISH, (MEETS 96 HR. ASTM STD. B-117 SALT SPRAY REQ.)

NO	COMPONENT NO	DESCRIPTION	QTY/M	U/M
-	-	-	-	-
-	-	-	-	-
-	-	-	-	-

BILL OF MATERIAL

UNLESS OTHERWISE SPECIFIED, DIMENSIONS ARE IN MILLIMETERS. DIMENSIONS IN BRACKETS [] ARE INCHES

UNLESS OTHERWISE SPECIFIED, DIMENSIONS DO NOT INCLUDE PLATING.

⊙	DENOTES CRITICAL CHARACTERISTICS.
CPK	DENOTES CPK DIMENSIONS. -MINIMUM CPK VALUE
ST	DENOTES A CHARACTERISTIC THAT PROVIDES AN INDICATION OF PROCESS PERFORMANCE. PROCEDURE FOR MEASUREMENT AND TRACKING TO BE DEFINED IN LITTELFUSE INSPECTION INSTRUCTIONS
CP	DENOTES CP DIMENSIONS. -MINIMUM CP VALUE MUST BE WITHIN THE DIMENSIONAL LIMITATIONS SHOWN ON DRAWING AND INITIALLY LOCATED TO ALLOW FOR MAXIMUM TOOL LIFE

COPIES TO	MATL SPEC
1 9 18	FINISH
2 10 19	
3 12 20	
4 13 21	DRW DJG DATE 02/03/06 SCALE 1:1
5 14 23	CHK DATE SUPER DR
6 15 33	APPD DATE FINISH GOOD WT
7 16 43	
8 17 53	GRAMS/PIECE

TOLERANCE UNLESS OTHERWISE SPECIFIED
ONE PLACE DEC +/- .3 THREE PLACE DEC +/- .100
TWO PLACE DEC +/- .25 ANGULAR +/- .1°

TITLE	3 POLE MEGA HOLDER FOR 400A & TWO 250A
REVISION	D
DRWG. NO.	02983005ZXT
OUTLINE	

METRIC

Littelfuse
DES PLAINES, ILLINOIS 60016

REVISION D
DRWG. NO. 02983005ZXT
OUTLINE

CAD GENERATED DRAWING - NO PENCIL CHANGES ALLOWED