

THIS DRAWING AND THE INFORMATION CONTAINED WITHIN IT ARE CONFIDENTIAL AND MAY NOT BE COPIED OR DISCLOSED WITHOUT THE WRITTEN PERMISSION OF LITTELFUSE.

PART NUMBER	DESCRIPTION
04980932ZXT	2-WAY SEALED MIDI HOLDER
04980933ZXT	3-WAY SEALED MIDI HOLDER

REVISIONS				
ZONE	REV.	DESCRIPTION	DATE	APPROVED
	A	ERN: 511514 CAD INITIAL ALPHA RELEASE SYU	03/19/2015	
B4, 2- B2, 2- B5, 2- B7, 2- B8, 2- E6	B	ECR: 524726 ADDED NOTES TO SHEET 1, 'DIMENSIONS' TOLERANCES ADDED, PRODUCT SPECIFICATION TABLE DELETED, BOM BALLONS UPDATED, BOM MODIFICATION, SHEET 2 NOTES MODIFICATION, TABLE A & B MODIFICATION, TOLERANCE BLOCK DELETED, SHEET SIZE MODIFICATION, SHEET FORMAT UPDATED. J. VELEZ	02/23/2024	L. ARGIL

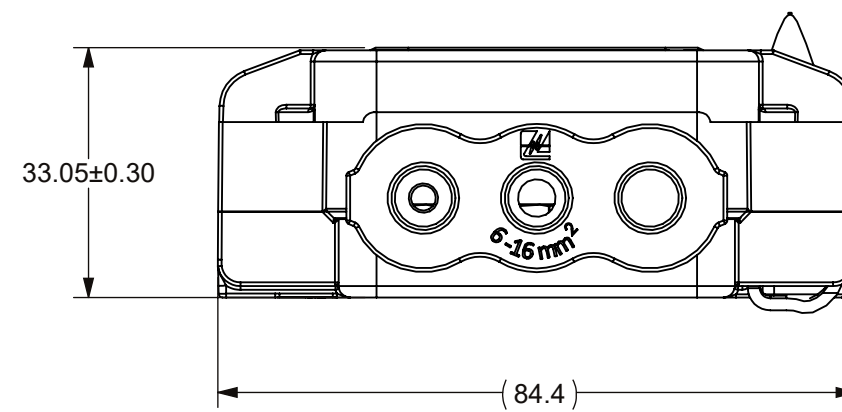
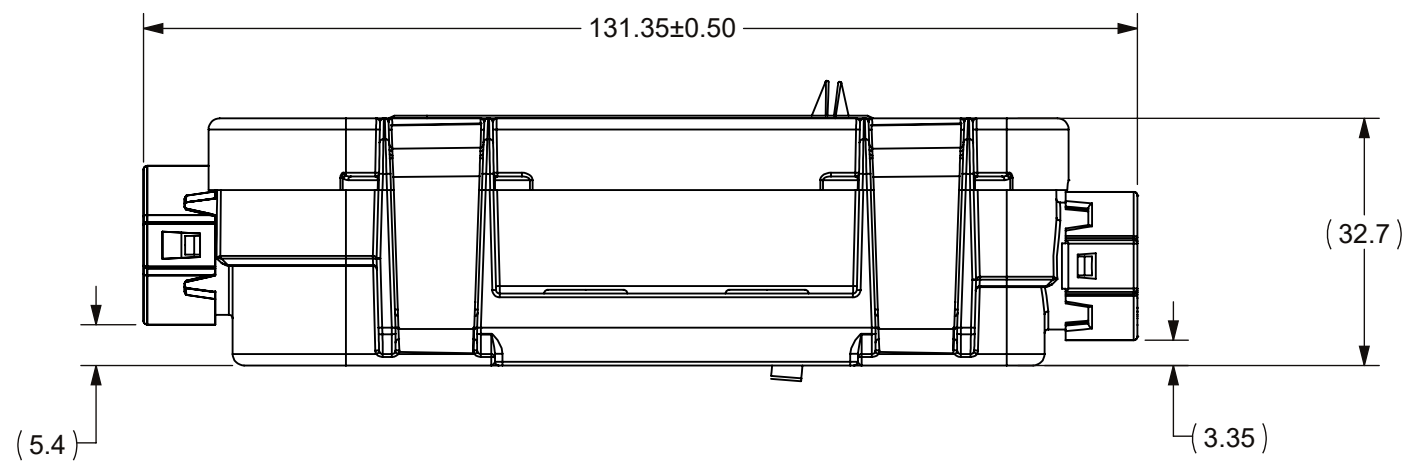
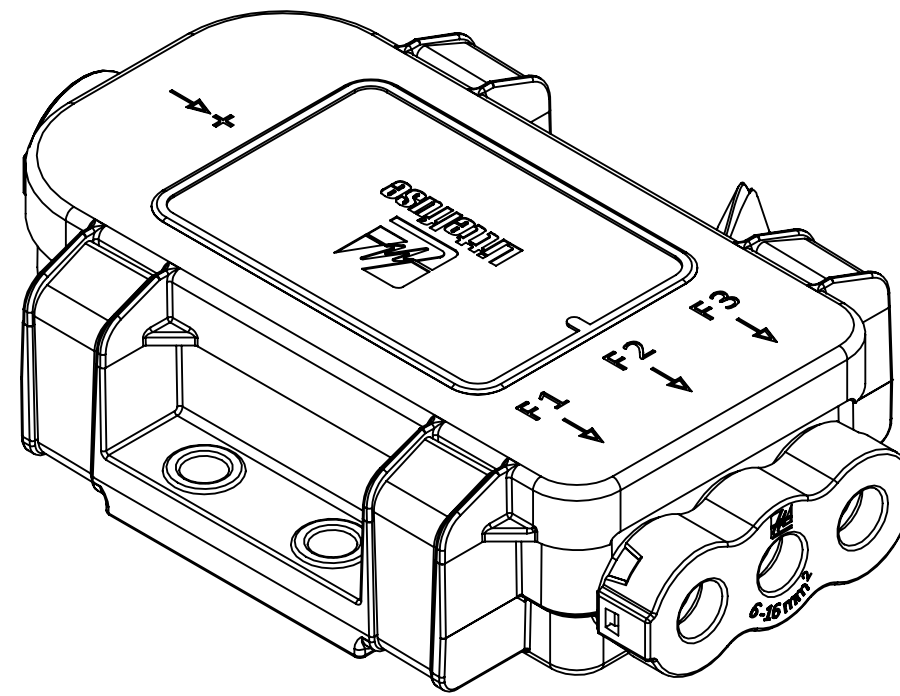
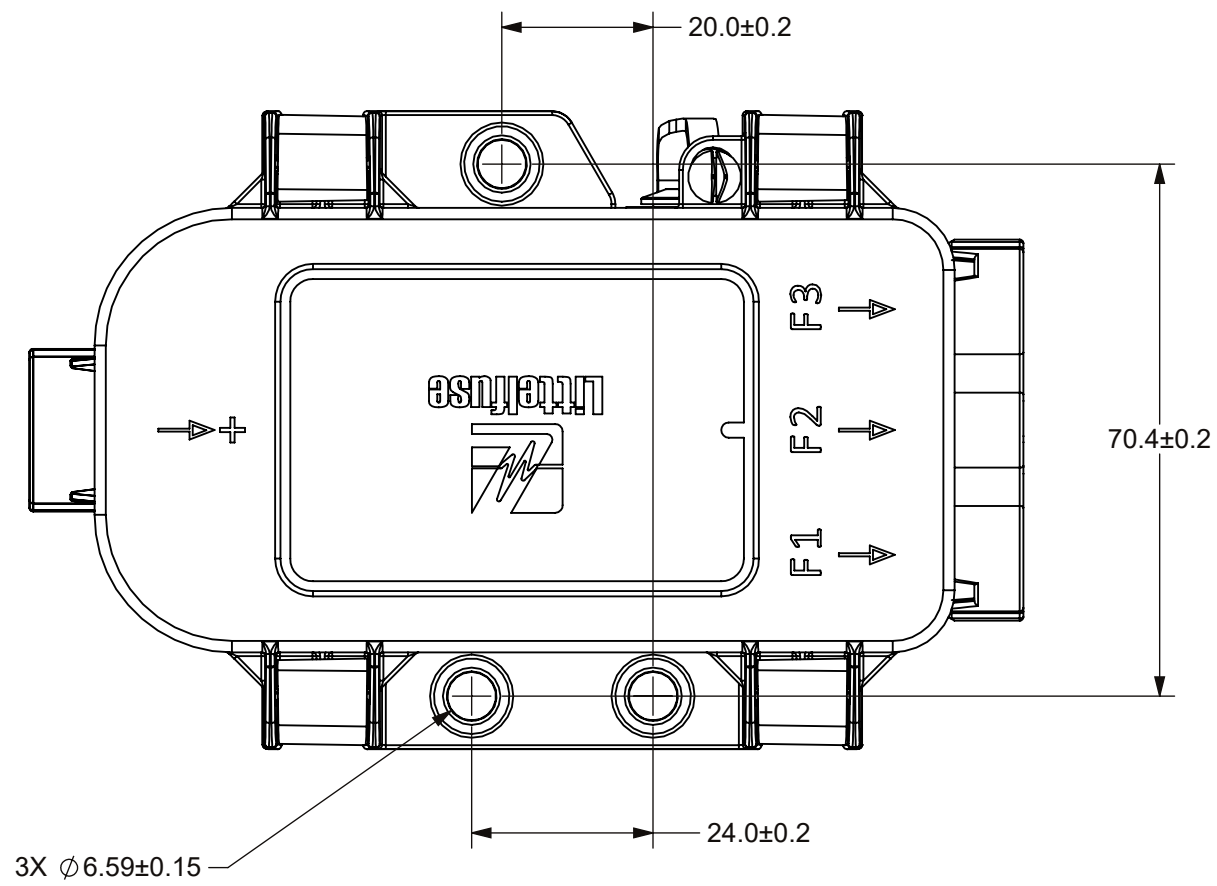

ⓑ NOTES:

- MATERIAL AND FINISH:
 - HOUSING: NYLON
 - COVER: PC
 - COVER GASKET: SILICONE RUBBER
 - BOLT M5X0.8 STEEL ZINC PLATED
 - FLANGE LOCKNUT M5X0.8 STEEL ZINC PLATED
- MOUNTING HOLE TORQUE: 5 Nm MAXIMUM
- APPROXIMATE WEIGHT OF PART 0.2 KG (NO FUSES)
- OTHERS REFER TO PRODUCT SPECIFICATION TABLES IN SHEET 2.

DIMENSIONS ARE SHOWN IN MILLIMETERS. DIMENSIONS AND TOLERANCES ARE DEFINED ACCORDING TO ANSI/ASME Y14.5-1994.	
●	FTI/ FUNCTION CRITICAL CHARACTERISTICS
<S>	SAFETY/ COMPLIANCE CRITICAL CHARACTERISTICS SYMBOL
CPK	DENOTES CPK DIMENSIONS MINIMUM CPK VALUE
(ST)	DENOTES A CHARACTERISTIC THAT PROVIDES AN INDICATION OF PROCESS PERFORMANCE. PROCEDURE FOR MEASUREMENT AND TRACKING TO BE DEFINED IN LITTELFUSE INSPECTION INSTRUCTIONS
CP	DENOTES CP DIMENSIONS. -MINIMUM CP VALUE MUST BE WITHIN THE DIMENSIONAL LIMITATIONS SHOWN ON DRAWING AND INITIALLY LOCATED TO ALLOW FOR MAXIMUM TOOL LIFE
NAME	DATE
DRAWN SYU	03/19/2015
CHECKED	
Littelfuse Expertise Applied Answers Delivered	
FORM NO. CVP-PE40-0005 REV B	TITLE NEW 2_3 WAY MIDI FUSE BOX
THIRD ANGLE PROJECTION	
SIZE C	DWG. NO. OL-04980933ZXT
DO NOT SCALE DRAWING	SCALE 1:1
	REV. B
	SHEET 1 OF 3

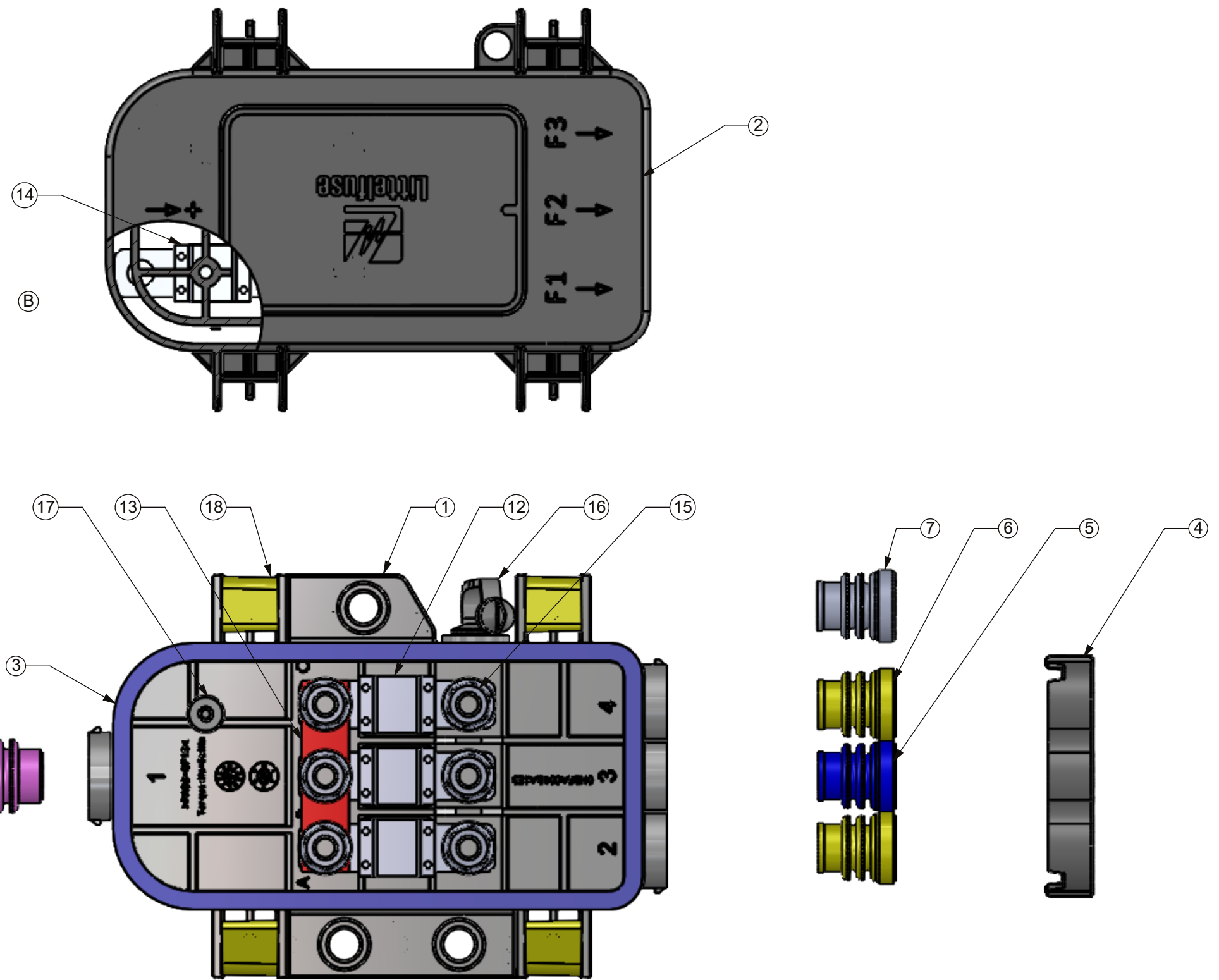

- NOTES:
1. PURCHASE THE CORRECT CAPS AND CABLE SEAL BASED ON THE CABLE SIZE WHICH YOU ARE USING FOR INPUTS AND OUTPUTS, SEE TABLE A AND B.
 2. PURCHASE THE CORRECT CURRENT RATING MIDI FUSE BASED ON ELECTRICAL LOAD REQUIREMENT.
 3. CABLE RING TERMINALS ARE PROVIDED BY CUSTOMER.
 4. VIEW AND BOM SHOW THE 3 WAY FUSE HOLDER HOUSING AND BUS BAR.

TABLE A
(FRONT CABLE SEAL & CAP OPTION)

INPUT CABLE CAP	INPUT CABLE SEAL
0HBF0003ZXCAP25	8
0HBF0003ZXCAP16	9

TABLE B
(BACK CABLE SEAL & CAP OPTION)

OUTPUT CABLE SEAL	OUTPUT CABLE CAP	NOTES
0HBFA001SEALB	4	ONE HOLE BLOCKED IN 2 WAY HOUSING
0HBFA001SEALY		
0HBFA001SEALC		

TABLE C
(2/3 WAY MIDI FUSE HOLDER ASSEMBLY MATRIX)

ASSEMBLY PN	DESCRIPTION	COVER	HOUSING	BUS BAR	TETHER	LATCH	COVER SEAL	M3 SCREW	M5 NUT
04980933ZXT	3 WAY FH	-	-	0HBF0001ZX3BBAR	873-680	0HBFA001CLIP	-	-	-
04980932ZXT	2 WAY FH	-	-	0HBF0001ZX2BBAR	-	-	-	-	-

ITEM NO.	PART NUMBER	DESCRIPTION	QTY.	UM
18	0HBFA001CLIP	2_3 WAY LATCH	4	EA
17	-	2_3 WAY SCREW	4	EA
16	873-680	TETHER BLACK	1	EA
15	-	FLANGE LOCKING NUT M5 X0.8 STEEL ZINC PLATED	6	EA
14	-	SPARE MIDI FUSE	2	EA
13	0HBF0001ZX3BBAR	3 WAY BUS BAR	1	EA
12	-	MIDI FUSE	3	EA
11	0HBF0003ZXCAP16	CAP FRONT INPUT, 16 mm2	1	EA
10	0HBF0003ZXCAP25	CAP FRONT INPUT, 25 mm2	1	EA
9	0HBF0003ZXS16-PK	CABLE SEAL 16 mm2 INPUT (PINK)	1	EA
8	0HBF0003ZXS25-GN	INPUT CABLE SEAL 25 mm2 (GREEN)	1	EA
7	0HBFA001SEALC	CABLE SEAL BLIND (GRAY)	1	EA
6	0HBFA001SEALY	CABLE SEAL 6-10 mm2 (YELLOW)	2	EA
5	0HBFA001SEALB	CABLE SEAL 10-16 mm2 (BLUE)	1	EA
4	0HBFA001CAPB	BACK CAP, 6-16 mm Sq	1	EA
3	-	2_3 WAY SEAL	1	EA
2	-	2_3 WAY LID	1	EA
1	-	3 WAY HOUSING	1	EA

PER CHNFPD00-008 PROCEDURE

ITEM NO. PART NUMBER DESCRIPTION QTY. UM

FORM NO. CVP-PE40-0005 REV B
THIRD ANGLE PROJECTION

DO NOT SCALE DRAWING SCALE 1:2 SHEET 2 OF 3

Littelfuse
Expertise Applied | Answers Delivered

TITLE: NEW 2_3 WAY MIDI FUSE BOX

SIZE C DWG. NO. OL-04980933ZXT REV. B

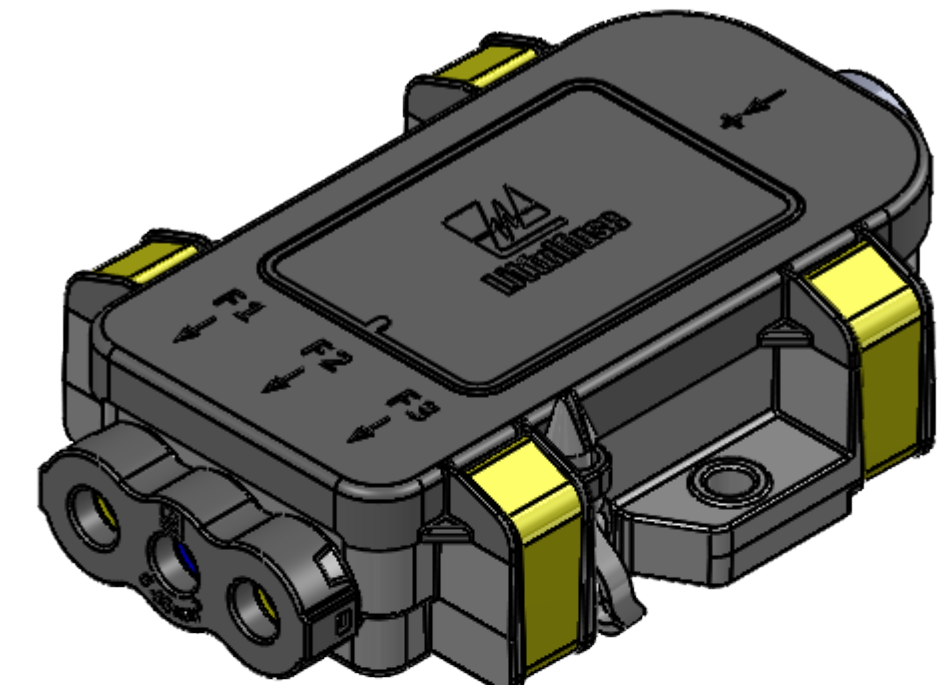
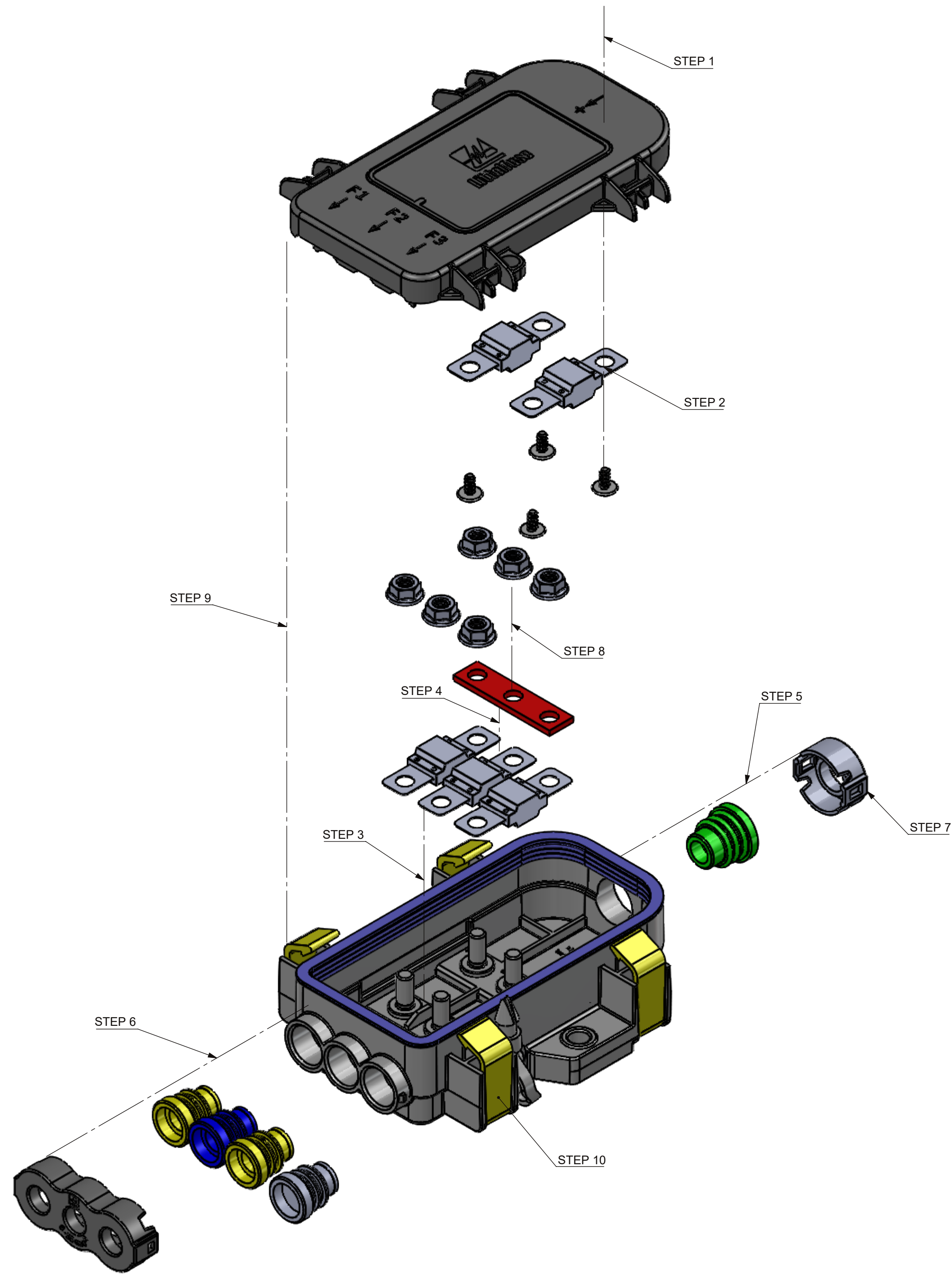

ASSEMBLY STEPS (FOR CUSTOMER ASSEMBLY USE ONLY):

- STEP 1: OPEN THE YELLOW LATCHES BY HAND OR THE USE OF A FLAT HEAD SCREW DRIVER, AND REMOVE COVER;
- STEP 2: (OPTIONAL) ADD SPARE MIDI FUSES TO THE COVER WITH PROVIDED SELF-TAPPING SCREWS (TORQUE: 2-3 Nm)
- STEP 3: INSTALL MIDI FUSES ONTO THE CORRECT CIRCUIT M5 STUDS, ENSURING THE FUSE BLADE IS SEATED TO THE BOTTOM;
- STEP 4: INSTALL THE BUS BAR ONTO M5 STUDS, ENSURE THE BUS BAR IS FULLY SEATED AND IN CONTACT WITH THE TOP FACE OF THE MIDI FUSE BLADE;
- STEP 5: CHOOSE THE CORRECT CABLE SEAL AND CAP BASED ON CABLE SIZE. INSTALL INPUT CABLE THROUGH FRONT CAP AND CABLE SEAL, AND THEN CONNECT RING TERMINAL. SLIDE THE INPUT CABLE ASSEMBLY THROUGH HOUSING, PLACING THE RING TERMINAL ONTO THE M5 STUD;
- STEP 6: CHOOSE THE CORRECT CABLE SEAL AND CAP BASED ON CABLE SIZE. INSTALL OUTPUT CABLE THROUGH BACK CAP AND CABLE SEAL, AND THEN CONNECT RING TERMINAL. SLIDE THE OUTPUT CABLE ASSEMBLY THROUGH HOUSING, PLACING THE RING TERMINAL ONTO CORRESPONDING M5 STUD. REPEAT FOR EACH OUTPUT CABLE;
- STEP 7: PRESS THE INPUT AND OUTPUT CABLE SEALS INTO THE HOUSING. SECURE BY SNAPPING THE FRONT CAP AND BACK CAP INTO POSITION WITH THE HOUSING;
- STEP 8: INSTALL M5 SELF LOCKING FLANGE NUTS ONTO EACH M5 STUD AND RING TERMINAL (TORQUE: 5 Nm);
- STEP 9: ASSEMBLE THE COVER (SEAL SEATED BY LATCHES) WITH HOUSING;
- STEP 10: CLOSE THE YELLOW LATCHES BY HAND, SNAPPING THEM OVER THE COVER.

DIMENSIONS ARE SHOWN IN MILLIMETERS. DIMENSIONS AND TOLERANCES ARE DEFINED ACCORDING TO ANSIS/ASME Y14.5-1994.	
●	FTI/ FUNCTION CRITICAL CHARACTERISTICS
<S>	SAFETY/ COMPLIANCE CRITICAL CHARACTERISTICS SYMBOL
CPK	DENOTES CPK DIMENSIONS MINIMUM CPK VALUE
(ST)	DENOTES A CHARACTERISTIC THAT PROVIDES AN INDICATION OF PROCESS PERFORMANCE. PROCEDURE FOR MEASUREMENT AND TRACKING TO BE DEFINED IN LITTELFUSE INSPECTION INSTRUCTIONS
CP	DENOTES CP DIMENSIONS. -MINIMUM CP VALUE MUST BE WITHIN THE DIMENSIONAL LIMITATIONS SHOWN ON DRAWING AND INITIALLY LOCATED TO ALLOW FOR MAXIMUM TOOL LIFE
PER CHNFPD20-008 PROCEDURE	
NAME	DATE
DRAWN SYU	03/19/2015
CHECKED -	-
 Expertise Applied Answers Delivered	
FORM NO. CVP-PE40-0005 REV B	
THIRD ANGLE PROJECTION	
SIZE C	DWG. NO. OL-04980933ZXT
DO NOT SCALE DRAWING	SCALE 1:2
REV. B	
SHEET 3 OF 3	