

THIS DRAWING AND THE INFORMATION CONTAINED WITHIN IT ARE CONFIDENTIAL AND MAY NOT BE COPIED OR DISCLOSED WITHOUT THE WRITTEN PERMISSION OF LITTELFUSE.

REVISIONS				
REV.	DESCRIPTION	DATE	DESIGNED	APPROVED
A	First issue of outline drawing	02-Feb-21	L.Dal Molin	M.Tinto

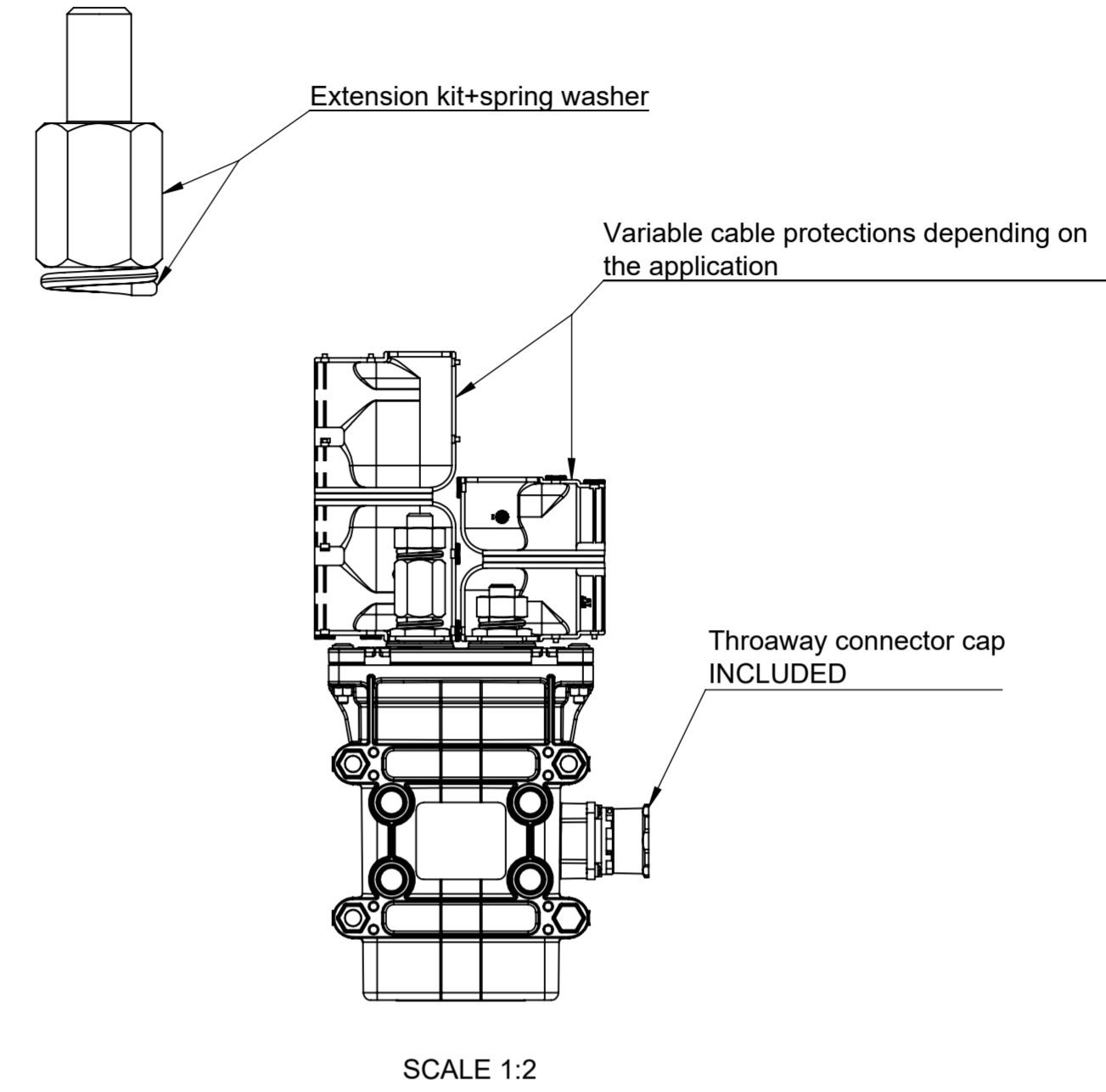

POS.	DESCRIPTION	MATERIAL	Q.TY	U/M
11	Nut M10	Brass	2	EA
10	Spring washer	Bronze	2	EA
9	Plane washer 10.2x18x2	Brass	2	EA
8	Power stud M10 short	Copper	2	EA
7	Fixing nut for screw	Copper	2	EA
6	Body connector	PBT	1	EA
5	OR ring	Silicon	1	EA
4	Self-tapping screw TCCIC 3x12	Steel	4	EA
3	Top cover	Thermosetting	1	EA
2	Screw M4x20	Steel	4	EA
1	Box short connector screws	PBT	1	EA

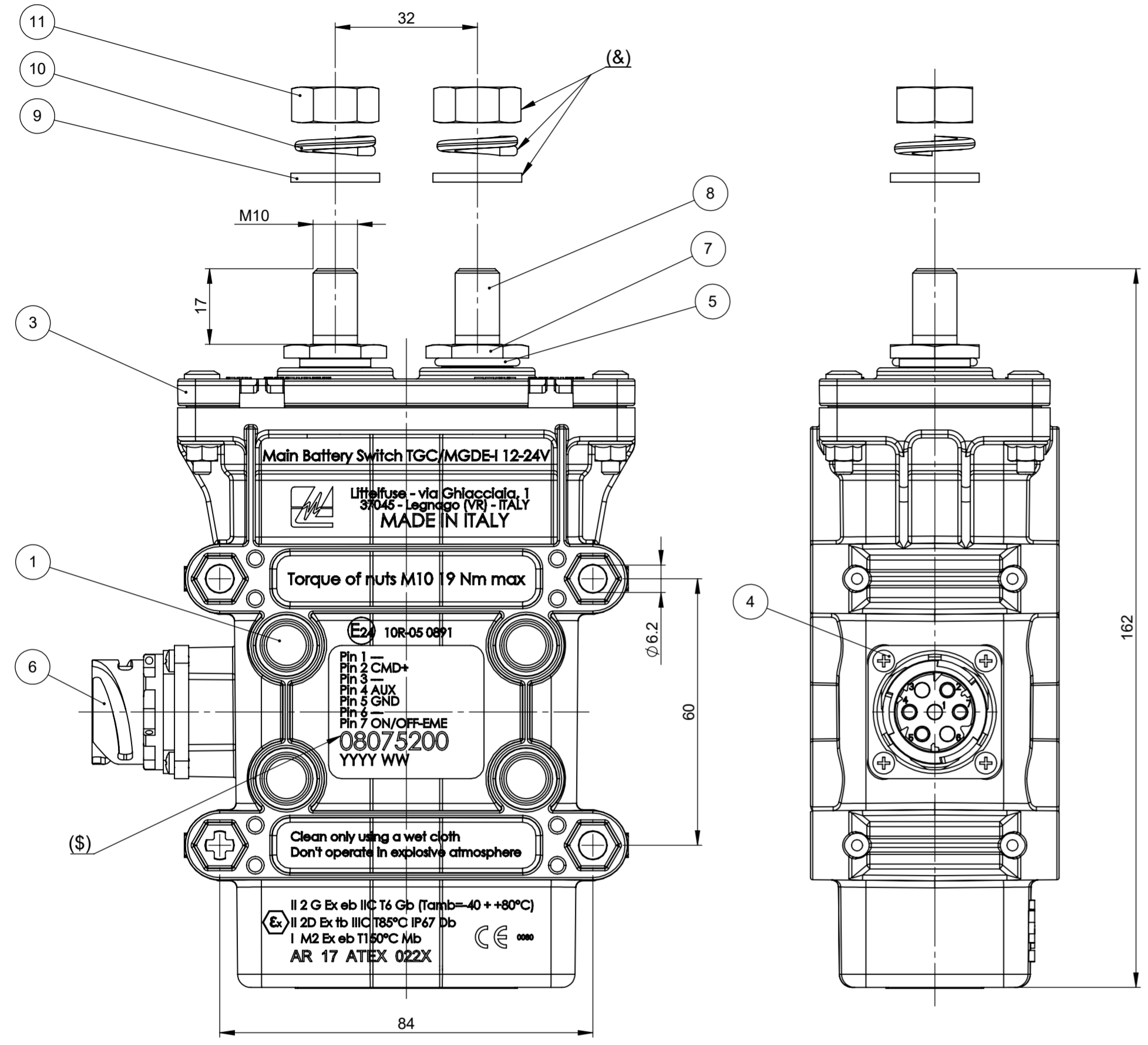
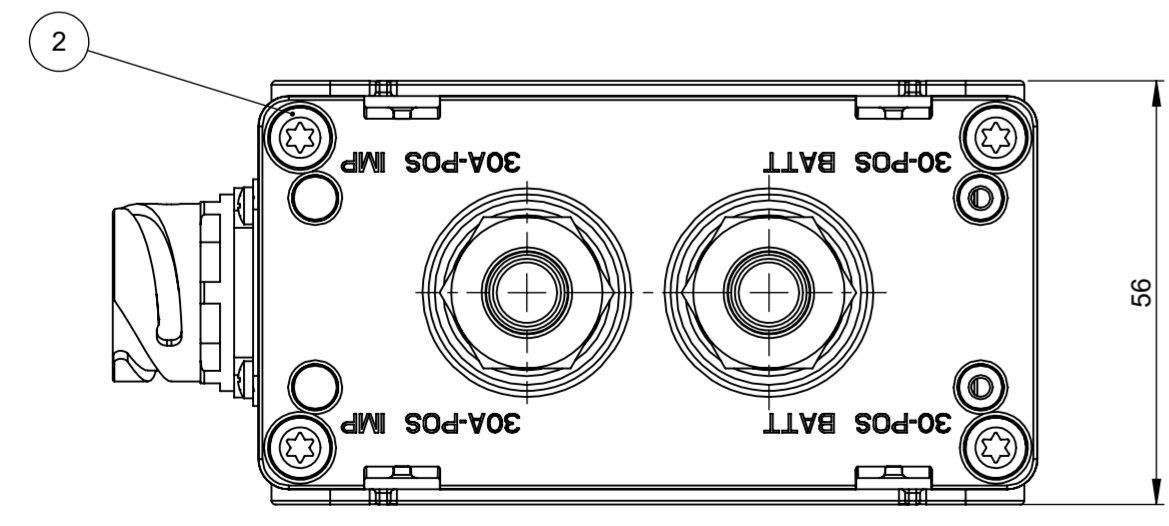

DOCUMENTO CORRELATO AL CERTIFICATO:  
DOCUMENT CORRELATED TO THE CERTIFICATE:

**AR 17 ATEX 022X**

Non sono ammesse modifiche senza l'approvazione della "Persona Autorizzata".  
No modify is allowed without the "Authorized Person" approval.

PRESCRIPTIONS:

- Torque of screw M10=19 Nm max
- Fix the device with M6 screw and with torque of 6±2 Nm
- (&) Provided in the kit
- (\$) p/N of product

CHARACTERISTICS:

- Nominal voltage: 12V or 24V
- Working current main contact: 250A
- Max current main contact: 2000A for 5 sec.

SAP drawing number:  
Material and treatments:

NAME		DATE
DRAWN	L. Dal Molin	02-Feb-21
CHECKED	-	-
FORM NO.	CVP-PE40-0013 REV A	
FIRST ANGLE PROJECTION	FIRST ANGLE PROJECTION	
DO NOT SCALE DRAWING	SCALE 1:1	SHEET 1 OF 1

DIMENSIONS AND TOLERANCES IN MILLIMETERS, DEFINED ACCORDING TO ISO 1101-2017.						
linear dimensions						
0,5	>3	>6	>30	>120	>400	>1000
3	6	30	120	400	1000	2000
±0,1	±0,1	±0,2	±0,3	±0,5	±0,8	±1,2
angle (for range of lengths)						
up to 10	>10	>50	>120	>400	>1000	>2000
±1°	±0°'30"	±0°'20"	±0°'10"			

●	FIT/ FUNCTION CRITICAL CHARACTERISTICS SYMBOL
<S>	SAFETY/ COMPLIANCE CRITICAL CHARACTERISTICS SYMBOL
CPK	DENOTES CPK DIMENSIONS MINIMUM CPK VALUE
ST	DENOTES A CHARACTERISTIC THAT PROVIDES AN INDICATION OF PROCESS PERFORMANCE. PROCEDURE FOR MEASUREMENT AND TRACKING TO BE DEFINED IN LITTELFUSE INSPECTION INSTRUCTIONS
CP	DENOTES CP DIMENSIONS. MINIMUM CP VALUE MUST BE WITHIN THE DIMENSIONAL LIMITATIONS SHOWN ON DRAWING AND INITIALLY LOCATED TO ALLOW FOR MAXIMUM TOOL LIFE

<b>Littelfuse</b>	
Expertise Applied   Answers Delivered	
TITLE TGC/MGDE-I 12-24V DIN 7P	
SIZE: A2	DWG. NO. OL-08075200
REV. A	