

THIS DRAWING AND THE INFORMATION CONTAINED WITHIN IT ARE CONFIDENTIAL AND MAY NOT BE COPIED OR DISCLOSED WITHOUT THE WRITTEN PERMISSION OF LITTELFUSE.

REVISIONS

REV.	DESCRIPTION	DATE	DESIGNED	APPROVED
A	Initial Release	28-Jul-22	L.Dal Molin	M.Tinto

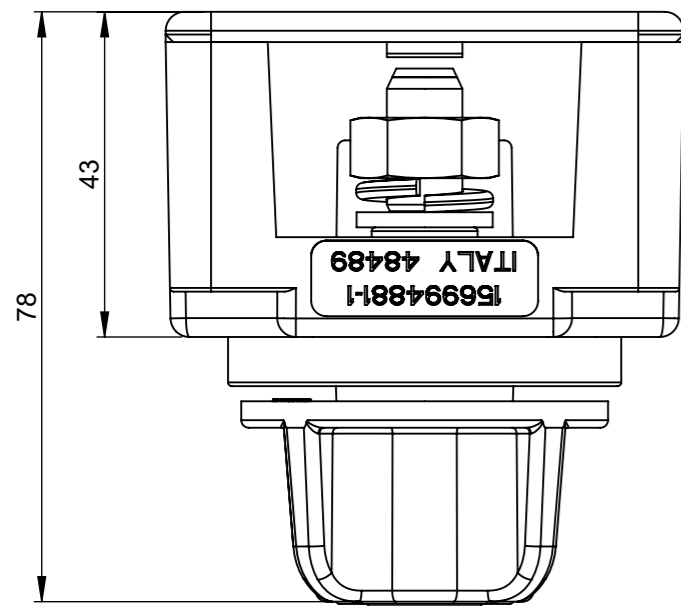
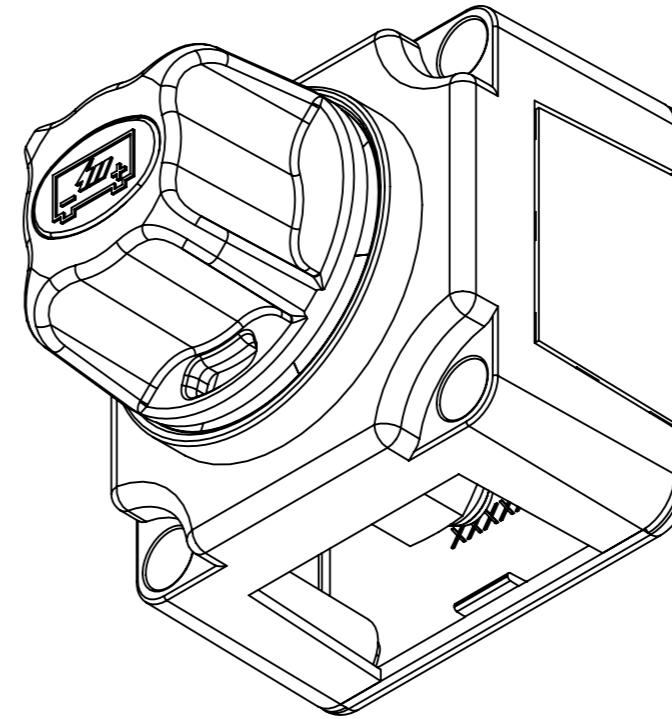
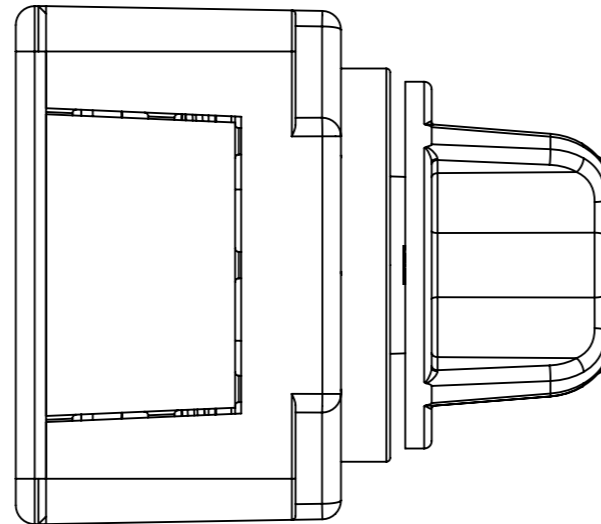
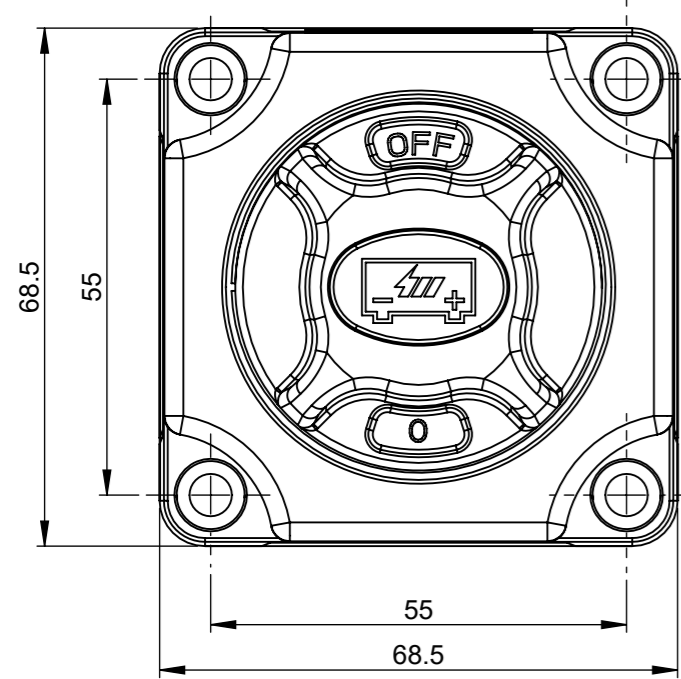

ELECTRICAL DIAGRAM

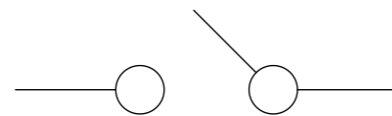

CHARACTERISTIC AND PRESCRIPTION

- Nominal voltage: 8V±32V
- Maximum continuous current: 150A
- Maximum current 1000A for 5 sec
- Maximum short time current 400A for 30 sec
- Tightening torque M10 nuts: 10 ± 1Nm
- Tightening torque M5 nuts: 6 ± 1Nm
- Handle with four step 90° ON-OFF / ON-OFF 360° rotate continuous

DIMENSIONS AND TOLERANCES IN MILLIMETERS, DEFINED ACCORDING TO ISO 1101-2017.

linear dimensions						
0,5	>3	>6	>30	>120	>400	>1000
3	6	30	120	400	1000	2000
±0,2	±0,3	±0,5	±0,8	±1,2	±2	±3

angle (for range of lengths)			
up to	>10	>50	>120
10	50	120	400
±1°30'	±1°	±0°30'	±0°15'

●	FIT/ FUNCTION CRITICAL CHARACTERISTICS SYMBOL
<S>	SAFETY/ COMPLIANCE CRITICAL CHARACTERISTICS SYMBOL
CPK	DENOTES CPK DIMENSIONS MINIMUM CPK VALUE
ST	DENOTES A CHARACTERISTIC THAT PROVIDES AN INDICATION OF PROCESS PERFORMANCE. PROCEDURE FOR MEASUREMENT AND TRACKING TO BE DEFINED IN LITTELFUSE INSPECTION INSTRUCTIONS
CP	DENOTES CP DIMENSIONS, -MINIMUM CP VALUE MUST BE WITHIN THE DIMENSIONAL LIMITATIONS SHOWN ON DRAWING AND INITIALLY LOCATED TO ALLOW FOR MAXIMUM TOOL LIFE

DRAWN	L. Dal Molin	2 Apr 2019	<p><b>Littelfuse</b> Expertise Applied   Answers Delivered</p>
CHECKED	-	-	
FORM NO: CVP-PE40-0013 REV A			
FIRST ANGLE PROJECTION			
TITLE			<p>IGC-150 MANUAL KNOB TO</p>
SIZE: A3	DWG. NO. OL-08081600	OUTLINE REV. A	
DO NOT SCALE DRAWING			SCALE 1:1
			SHEET 1 OF 1