

THIS DRAWING AND THE INFORMATION CONTAINED WITHIN IT ARE CONFIDENTIAL AND MAY NOT BE COPIED OR DISCLOSED WITHOUT THE WRITTEN PERMISSION OF LITTELFUSE.

REVISIONS				
REV.	DESCRIPTION	DATE	DESIGNED	APPROVED
A	First issue of outline drawing	28-May-20	L.Dal Molin	M.Tinto

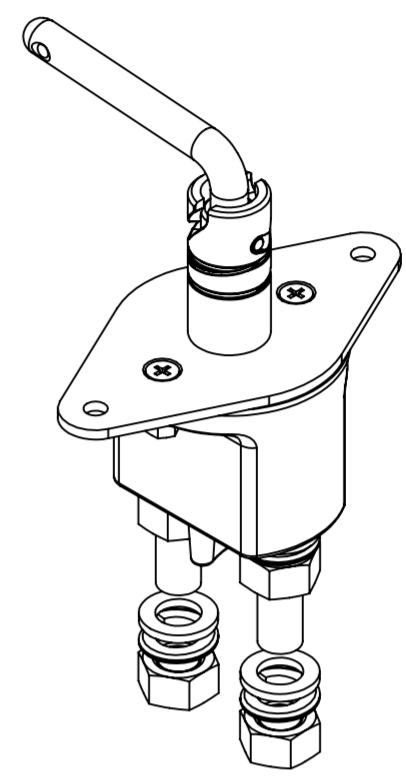
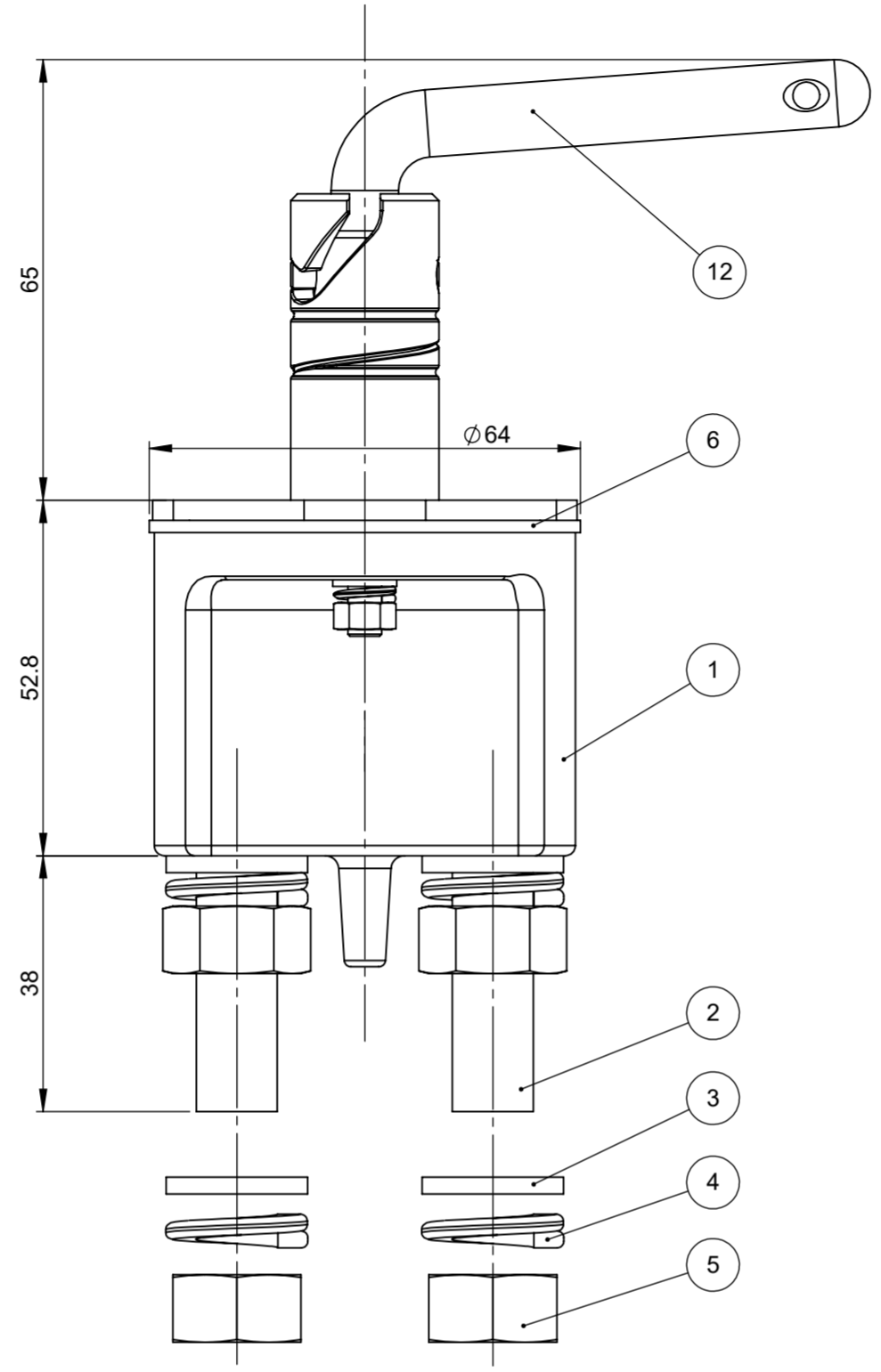
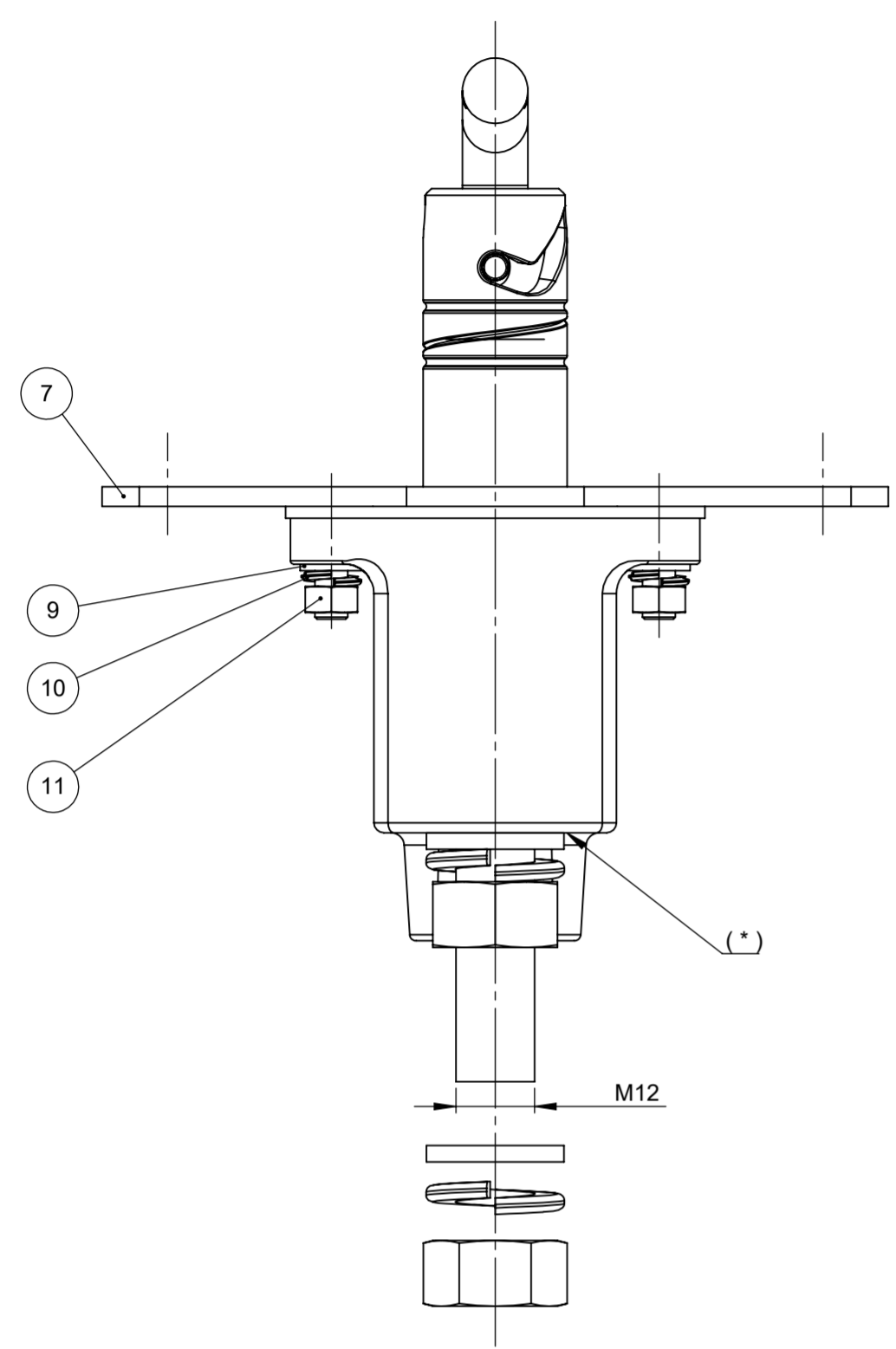

SCALE 1:2

POS.	P/N	DESCRIPTION	MATERIAL	Q.TY	U/M
12	08099800	Lever complete	Steel	1	EA
11		Nut M5	Steel	2	EA
10		Spring washer To 5	Steel	2	EA
9		Plain washer Tc 5.3x9	Steel	2	EA
8		Screw M5x20	Steel	2	EA
7		Upper body cam	Steel	1	EA
6		Gasket	Silicone rubber	1	EA
5		Nut M12x1.25	Steel	4	EA
4		Spring washer To 12	Steel	4	EA
3		Plain washer 13x21x2.5	Steel	4	EA
2		Screw fixed contact M12x1.25	Copper	2	EA
1		Cont.-holder 2xM12 long flame	Phenolic resin	1	EA

ELECTRICAL DIAGRAM

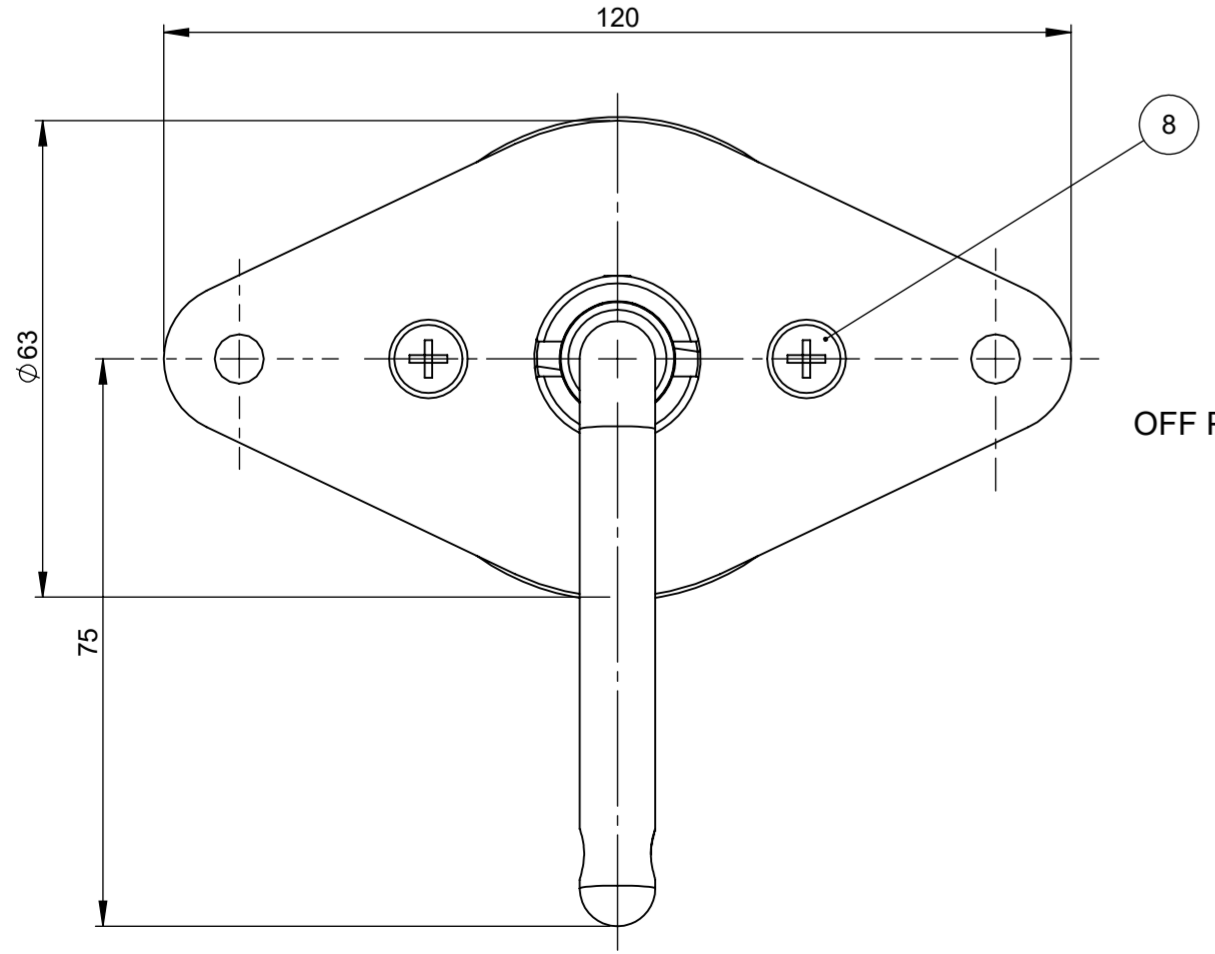
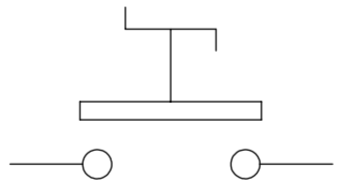

FIXING HOLES

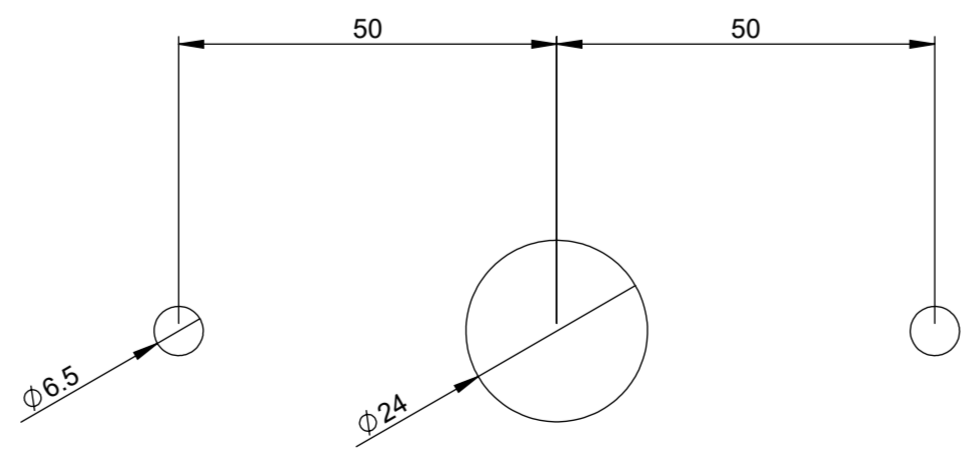

PRESCRIPTIONS

- (\*) Marking of date of manufacturing
- Torque of handle 3.5 ± 2 Nm at 23°C
- Currents:  
350A continuously  
2000A for 30seconds at 23°C  
2500A for 5seconds (short circuit) at 23°C
- Nominal tension: 12V ÷ 24V
- Number of electrical operations: 5000
- Number of mechanical operations: 5000

SAP drawing number:

Material and treatments:

NAME		DATE
DRAWN	L. Dal Molin	09-Apr-19
CHECKED	-	-
Expertise Applied   Answers Delivered		
FORM NO.: CVP-PE40-0013 REV A		TITLE
FIRST ANGLE PROJECTION		MANUAL MAIN SWITCH IGC/350F
SIZE: A2	DWG. NO.: OL-08098900	OUTLINE REV. A
DO NOT SCALE DRAWING		SCALE 1:1
		SHEET 1 OF 1