

THIS DRAWING AND THE INFORMATION CONTAINED WITHIN IT ARE CONFIDENTIAL AND MAY NOT BE COPIED OR DISCLOSED WITHOUT THE WRITTEN PERMISSION OF LITTELFUSE.

REV. DESCRIPTION		REVISIONS		
REV.	DESCRIPTION	DATE	DESIGNED	APPROVED
A	First issue of outline drawing	22-Jan-21	L.Dal Molin	M.Tinto
B	Note added	26-Mar-21	L.Dal Molin	M.Tinto

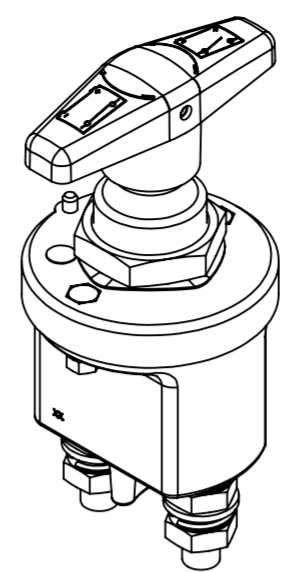
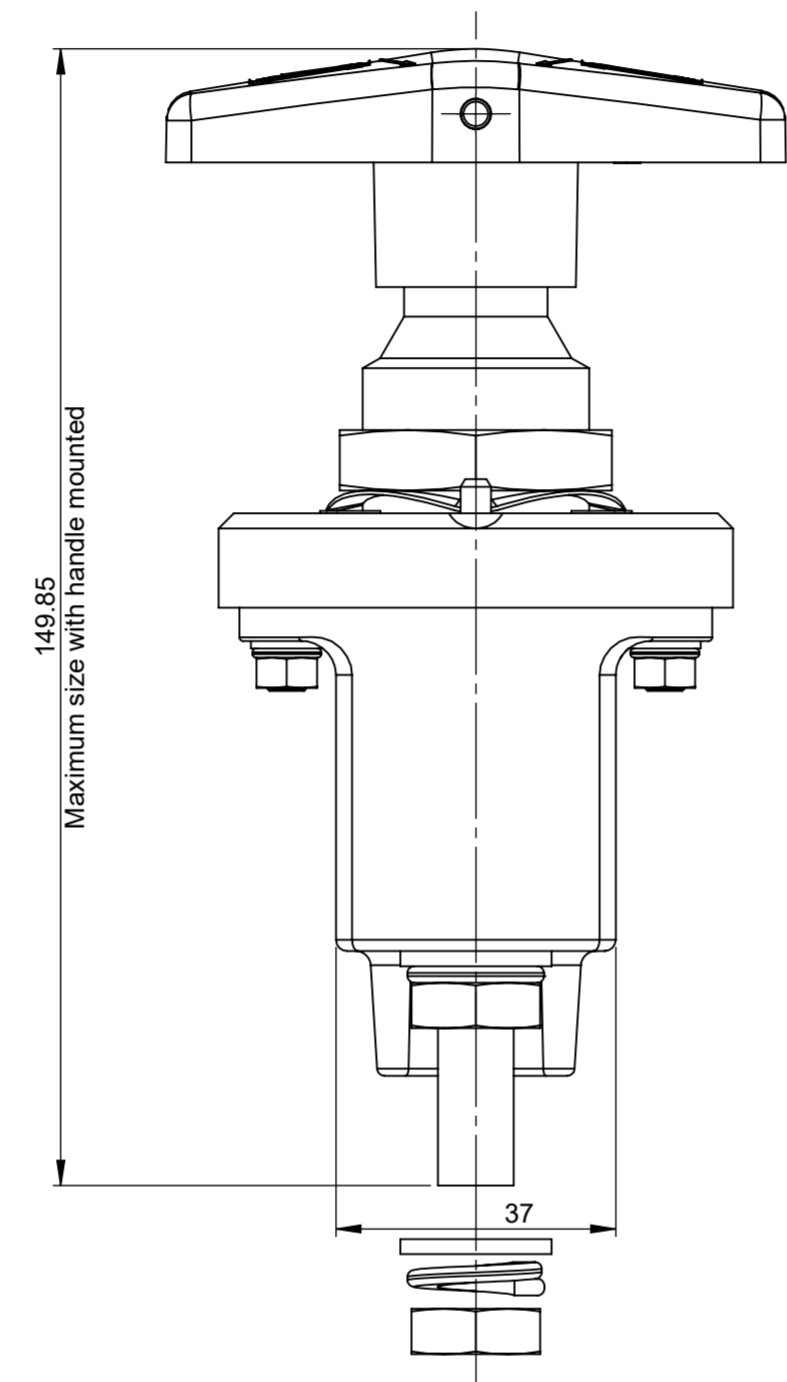
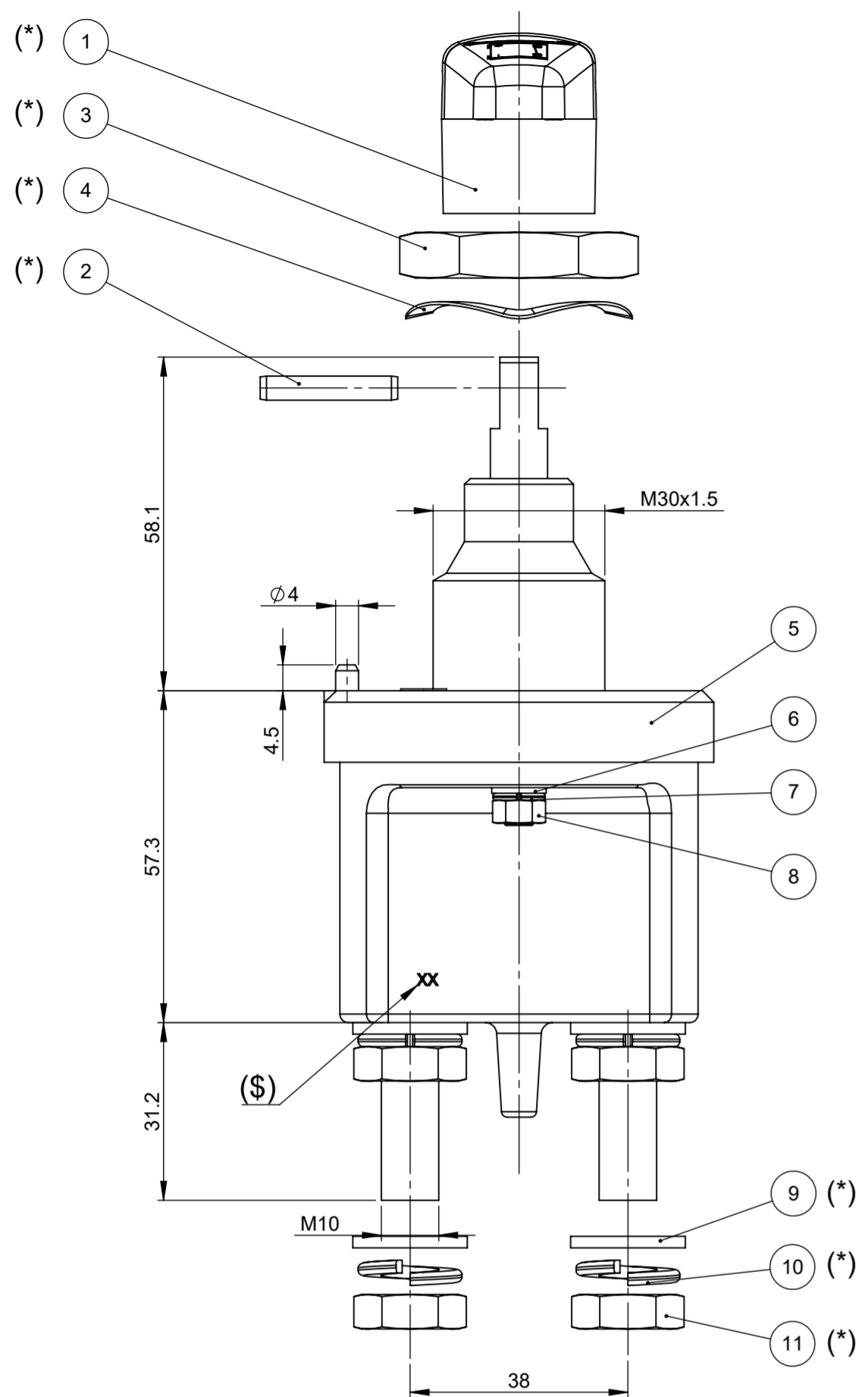

POS.	P/N	DESCRIPTION	MATERIAL	Q.TY	U/M
11		Nut M10	Brass	2	EA
10		Spring washer To 10	Steel	2	EA
9		Plane washer Te 10.5x20	Steel	2	EA
8		Nut M5	Steel	2	EA
7		Spring washer To 5	Steel	2	EA
6		Plane washer Tc 5.3x9.5	Steel	2	EA
5		Complete IGC		1	EA
4		Elastic ring	Steel	1	EA
3		Nut M30x1.5	Brass	1	EA
2		Spiral spring pin	Steel	1	EA
1		Handle	Aluminium	1	EA

OPEN CONTACTS POSITION  
"STATE OF SUPPLY"

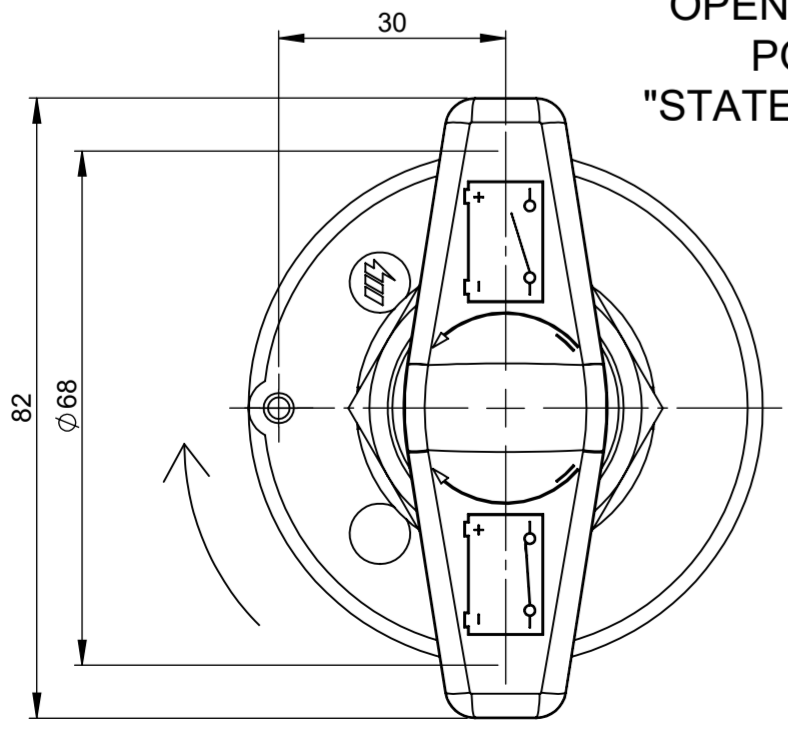

FIXING HOLES

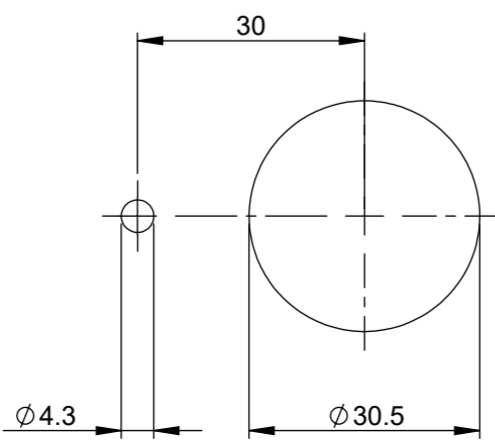

ELECTRICAL DIAGRAM

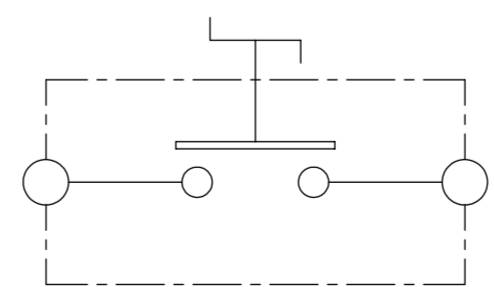

PRESCRIPTIONS

- Contacts lock by 90° clockwise rotation of handle
- (\$) Marking of manufacturing date, indifferently on right or left terminal
- (\*) Handle, spiral spring pin, nut M30x1.5, elastic ring, nuts and washers supplied in the kit

CHARACTERISTICS

- Max operating voltage: 24 DC
- Max continuous current: 250A & 350A
- Intermittent current: 2500A at 3 sec.
- Handle operating torque: 1.5(±0.5) Nm
- M10 low nut closing pair: 14(±3) Nm
- M5 nut closing pair: 1.5(±0.5) Nm
- Locking nut M30x1.5: 35(±5) Nm
- Maximum thickness lockable with nut M30: 12mm
- ⓑ - Handle operating torque: 2±0.5 Nm

SAP drawing number: 10000100231

Material and treatments:

DIMENSIONS AND TOLERANCES IN MILLIMETERS, DEFINED ACCORDING TO ISO 1101-2017.	
linear dimensions	
0,5 3	>3 6
±0,2	±0,3
>6 30	>30 120
±0,5	±0,8
>120 400	>400 1000
±1,2	±2
>1000 2000	
±3	
angle (for range of lengths)	
up to 10	>10 50
±1°30'	±1°
>50 120	>120 400
±0°30'	±0°15'
●	FIT/ FUNCTION CRITICAL CHARACTERISTICS SYMBOL
<S>	SAFETY/ COMPLIANCE CRITICAL CHARACTERISTICS SYMBOL
CPK	NOTES CPK DIMENSIONS MINIMUM CPK VALUE
ST	NOTES A CHARACTERISTIC THAT PROVIDES AN INDICATION OF PROCESS PERFORMANCE. PROCEDURE FOR MEASUREMENT AND TRACKING TO BE DEFINED IN LITTELFUSE INSPECTION INSTRUCTIONS
CP	NOTES CP DIMENSIONS. MINIMUM CP VALUE MUST BE WITHIN THE DIMENSIONAL LIMITATIONS SHOWN ON DRAWING AND INITIALLY LOCATED TO ALLOW FOR MAXIMUM TOOL LIFE
NAME	DATE
DRAWN L. Dal Molin	22-Jan-21
CHECKED -	-
<b>Littelfuse</b> Expertise Applied   Answers Delivered	
FORM NO. CVP-PE40-0013 REV A	
FIRST ANGLE PROJECTION	
TITLE 250A MANUAL BATTERY MASTER SWITCH WITH FIXED HANDLE	
SIZE: A2	DWG. NO. OL-08099164
DO NOT SCALE DRAWING	SCALE 1:1
	SHEET 1 OF 1