

Art.Nr.	DESCRIPTION
178.6125.0001	HOLDER COVER FOR FH2 100 PC
178.6125.0002	HOLDER COVER FOR FH2 1000 PC

LTR	DATE	REVISION	DRW
A	07/AUG/19	521154GCA-RELEASE	OPL

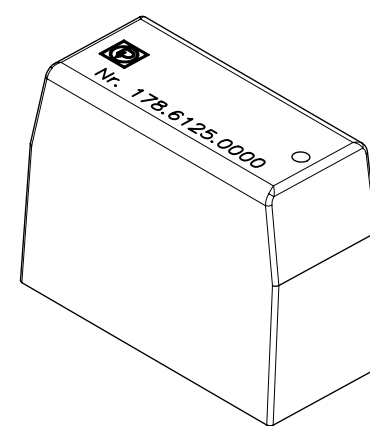

SCALE 2:1

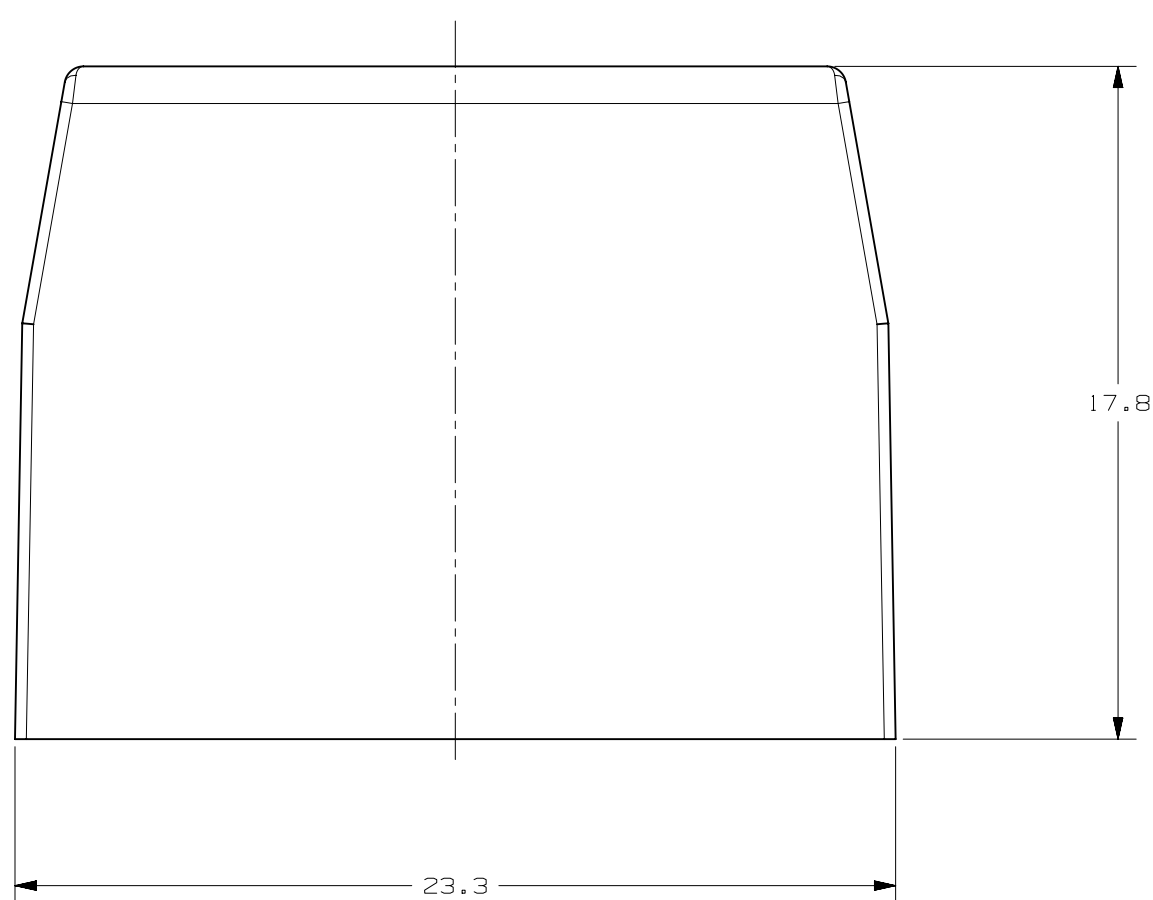
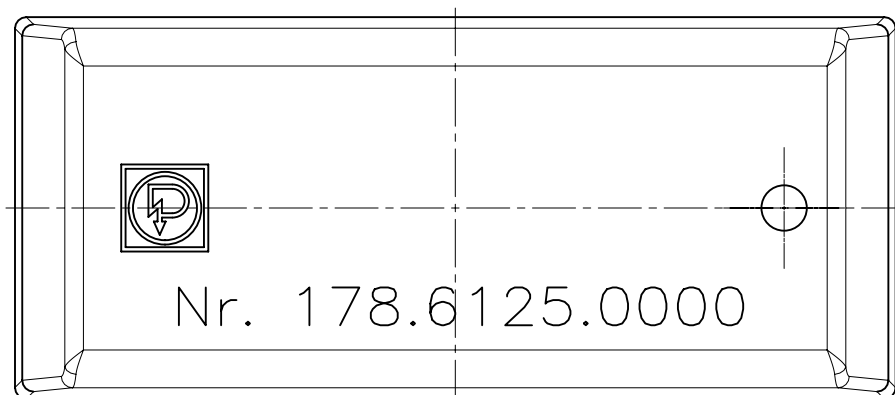

SCALE 5:1

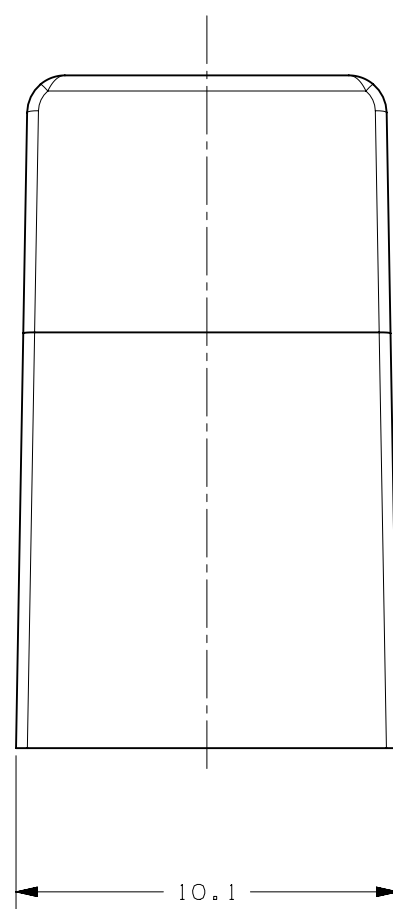

UNLESS OTHERWISE SPECIFIED, DIMENSIONS ARE IN MILLIMETERS. DUAL DIMENSIONS IN BRACKETS () ARE INCHES AND FOR REFERENCE ONLY.						
UNLESS OTHERWISE SPECIFIED, DIMENSIONS DO NOT INCLUDE PLATING.						
	CRITICAL CHARACTERISTIC FOR PART SAFETY/COMPLIANCE.					
	CRITICAL CHARACTERISTIC FOR PART FIT/FUNCTION.					
CPK	CPK DIMENSION. 1.67 MINIMUM CPK VALUE ON NEW TOOLING.					
	STATISTICAL PROCESS CONTROL DIMENSION. THIS DIMENSION INDICATES PROCESS PERFORMANCE. DATA SHALL BE TRACKED AND ANALYZED AT PERIODIC TIMES, ACC. TO CONTROL PLAN.					
CP	CP DIMENSION. 1.67 MINIMUM CP VALUE. MUST BE INITIALLY LOCATED TO ALLOW FOR MAXIMUM TOOL LIFE.					
	CUSTOMER-DESIGNATED CHARACTERISTIC. REQUIREMENT FOR EACH SYMBOL TO BE DEFINED IN A CONVERSION TABLE.					
	CLAMP DIMENSION. PARTS SHALL BE SECURED BEFORE TAKING DIMENSIONAL MEASUREMENTS. FIXTURING DATUMS & PROCEDURES TO BE DEFINED IN NOTES OR SEPARATE PROCESS DOCUMENTS.					
DIMENSIONS & TOLERANCES ACC. TO ASME Y14.5-2009	MATL SPEC	THERMOPLASTIC (TRANSPARENT)				
3RD ANGLE PROJECTION	FINISH		SIZE			
SCALE 5:1	DRW OPL	CHK MMQ	DATE 07/AUG/19			
TOLERANCES UNLESS OTHERWISE SPECIFIED						
LINEAR DIMENSIONS			ANGLES RADII			
DIM	UP TO .5	OVER 6 - 30	UP TO 30 - 120	OVER 120 - 400	±0.5°	±0.2
TOL	±0.05	±0.1	±0.15	±0.2		
TITLE FH2 HOLDER COVER						
		REVISION A	DRWG. NO. OL-178.6125.0000			
CHICAGO, USA 773-628-1000						

METRIC COMPONENT

CAD GENERATED DRAWING - NO PENCIL CHANGES ALLOWED (FORM rev S)