

THIS DRAWING AND THE INFORMATION CONTAINED WITHIN IT ARE CONFIDENTIAL AND MAY NOT BE COPIED OR DISCLOSED WITHOUT THE WRITTEN PERMISSION OF LITTELFUSE.

| REVISIONS | | | | |
|-----------|------|---------------------------------------|---------|-------------|
| ZONE | REV. | DESCRIPTION | DATE | APPROVED |
| | A | GCF #521133 NEW RELEASED C. MILLER | 7/22/19 | E.FERNANDEZ |

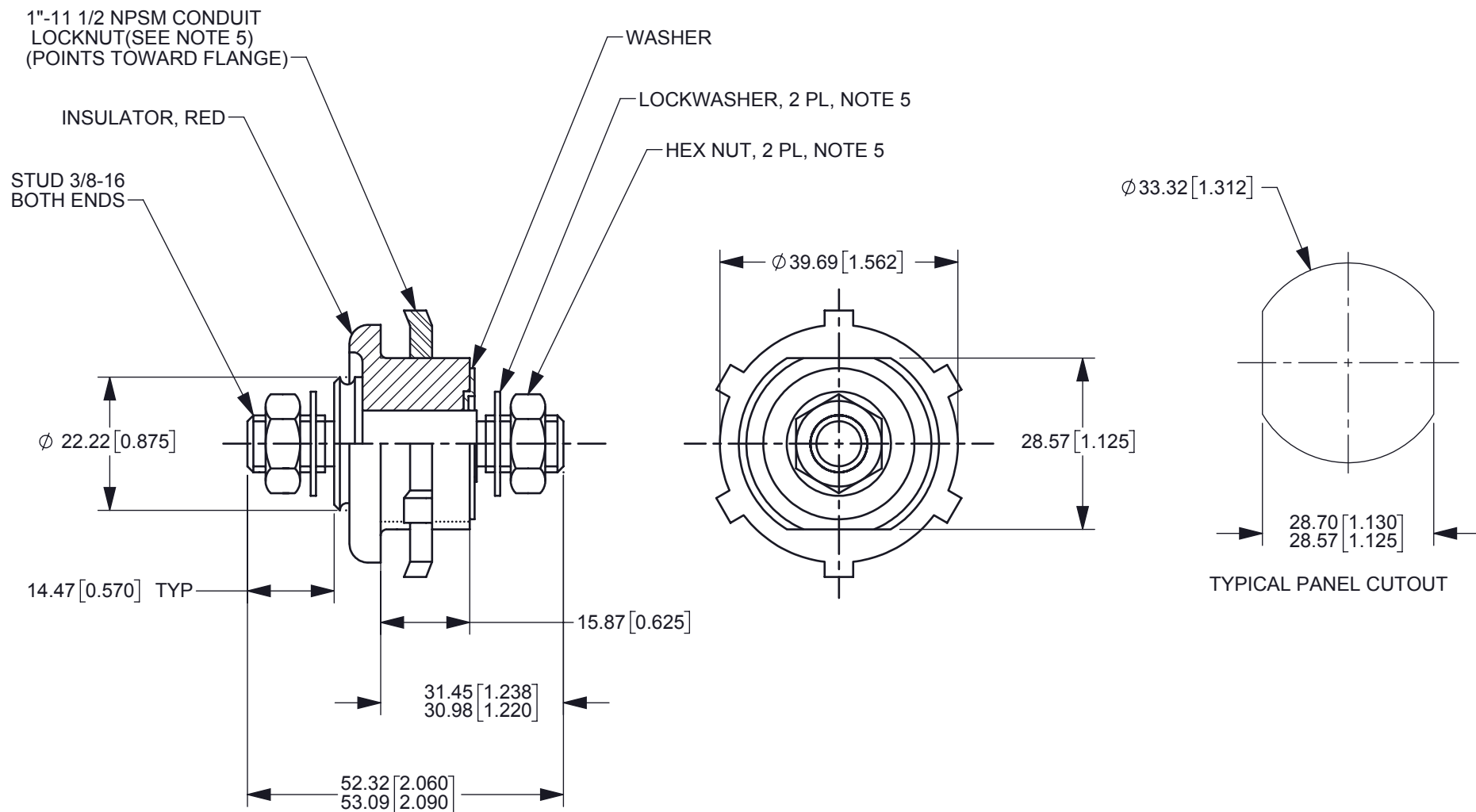

- NOTES:
1. ALL STEEL PARTS PLATED
 2. ALL DIMENSIONS ARE REFERENCE ONLY
 3. MOUNTING THREADS 1"-11 1/2 NPSM- MOUNTING TORQUE 10.8-13.5 Nm (8-10 FT LBS) NOT TO EXCEED 13.5 Nm (10 FT LBS)
 4. STUD 3/8"-16 TIGHTENING TORQUE 8.1-10.8 Nm (6-8 FT LBS)
 5. ALL HARDWARE SUPPLIED IN BAG

| | |
|---|--|
| INTERPRET DRAWING TO ANSI/ASME Y14.5-1994. | |
| ● | FIT/ FUNCTION CRITICAL CHARACTERISTICS SYMBOL |
| <S> | SAFETY/ COMPLIANCE CRITICAL CHARACTERISTICS SYMBOL |
| CPK | DENOTES CPK DIMENSIONS MINIMUM CPK VALUE |
| ST | DENOTES A CHARACTERISTIC THAT PROVIDES AN INDICATION OF PROCESS PERFORMANCE PROCEDURE FOR MEASUREMENT AND TRACKING TO BE DEFINED IN LITTELFUSE INSPECTION INSTRUCTIONS |
| CP | DENOTES CP DIMENSIONS. -MINIMUM CP VALUE MUST BE WITHIN THE DIMENSIONAL LIMITATIONS SHOWN ON DRAWING AND INITIALLY LOCATED TO ALLOW FOR MAXIMUM TOOL LIFE |
| DIMENSION: MM TOLERANCES UNLESS OTHERWISE SPECIFIED ONE PLACE DECIMAL ± 0.5 THREE PLACES DECIMAL ± 0.100 TWO PLACES DECIMAL ± 0.20 ANGULAR ± 2° | |
| DRAWN | C.MILLER 07/24/19 |
| CHECKED | A.HOANG 07/25/19 |
| Expertise Applied Answers Delivered | |
| FORM NO: CVP-PE40-0004 REV A | |
| THIRD ANGLE PROJECTION | |
| SIZE | DWG. NO. OUTLINE REV. |
| B | OL-46211-R A |
| DO NOT SCALE DRAWING | |
| SCALE 1:1 | SHEET 1 OF 1 |