

THIS DRAWING AND THE INFORMATION CONTAINED WITHIN IT ARE CONFIDENTIAL AND MAY NOT BE COPIED OR DISCLOSED WITHOUT THE WRITTEN PERMISSION OF LITTELFUSE.

REV.	DESCRIPTION	DATE	GCF / ECR	DESIGNED	APPROVED
A	Initial release	07 Nov 2023		T.Bianchin	M.Tinto

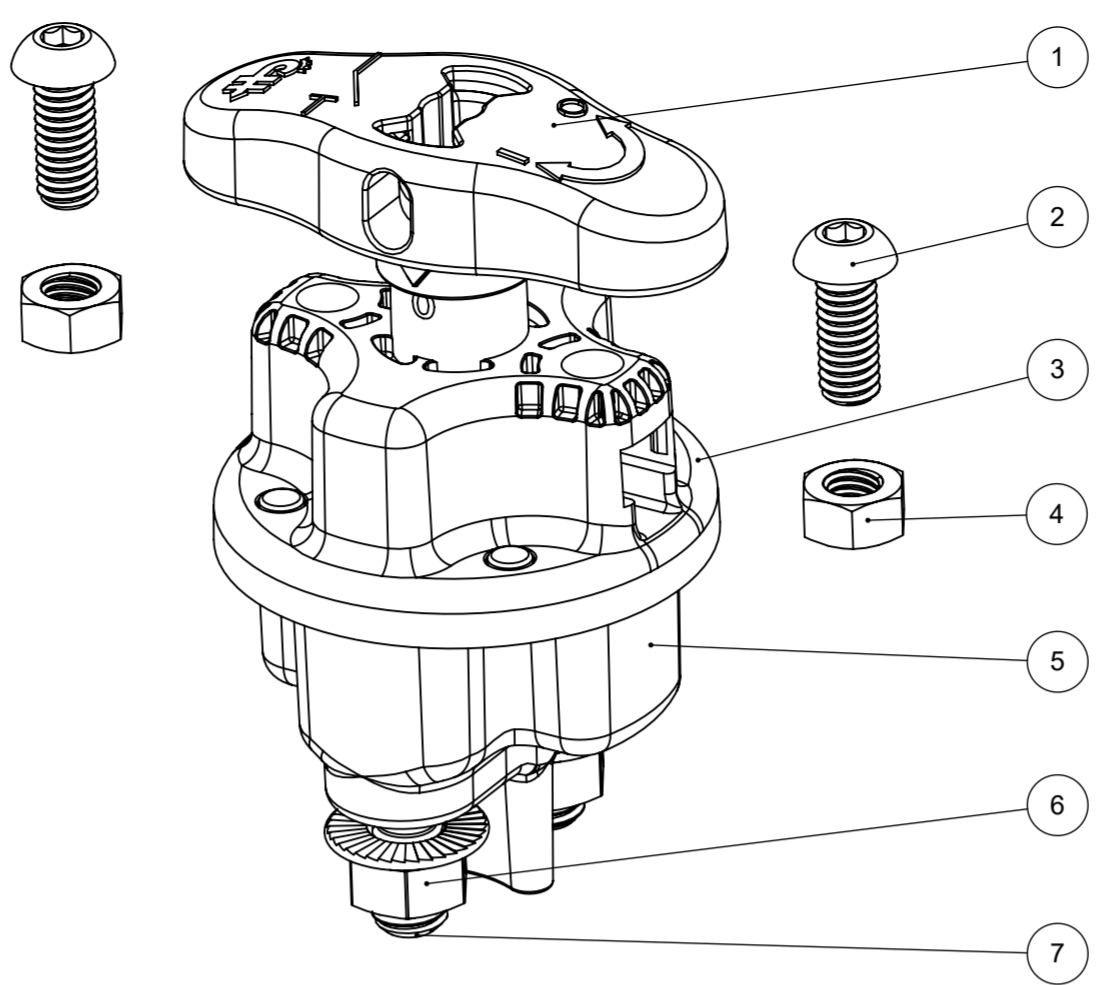
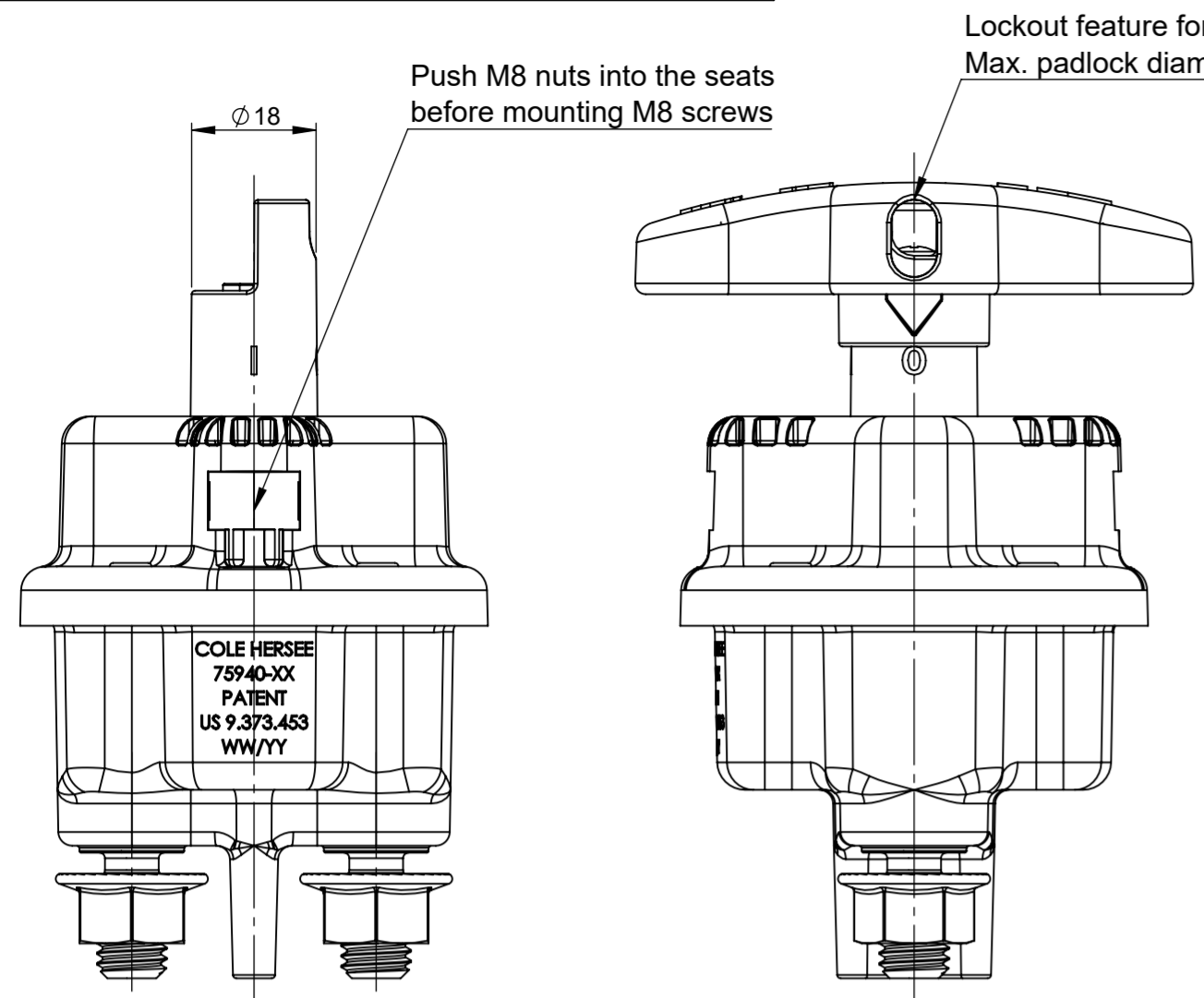

MASTER DISCONNECT SWITCH CONFIGURATION CHART			COMPLETE HANDLE LF SPARE PNS CHART		
PRODUCT NUMBER	HANDLE COLOR	PACKAGING	PRODUCT NUMBER	HANDLE COLOR	PACKAGING
75940-01-BP	RED	BLISTER	63989-A	RED	BULK
75940-02-BP	YELLOW	BLISTER	63988-A	YELLOW	BULK
75940-03-BP	BLACK	BLISTER	63990-A	BLACK	BULK
75940-01	RED	BULK			
75940-02	YELLOW	BULK			
75940-03	BLACK	BULK			

POS.	COMPONENT NAME	MATERIAL	Q.TY	NOTE
1	Complete handle	Thermoplastic reinforced PA66 class V-0, stainless steel	1	Pre-assembled
2	Screw M8	Stainless steel	2	Included in the kit Not assembled
3	Upper housing	Thermoplastic reinforced PA66 class V-0 colour black	1	
4	Nut M8 hex	Stainless steel	2	Included in the kit Not assembled
5	Backplate	Thermoplastic reinforced PPA class V-0 colour black	1	
6	Nut M10 hex flange	Stainless steel	2	Pre-assembled
7	Stud M10	Silver plated copper	2	

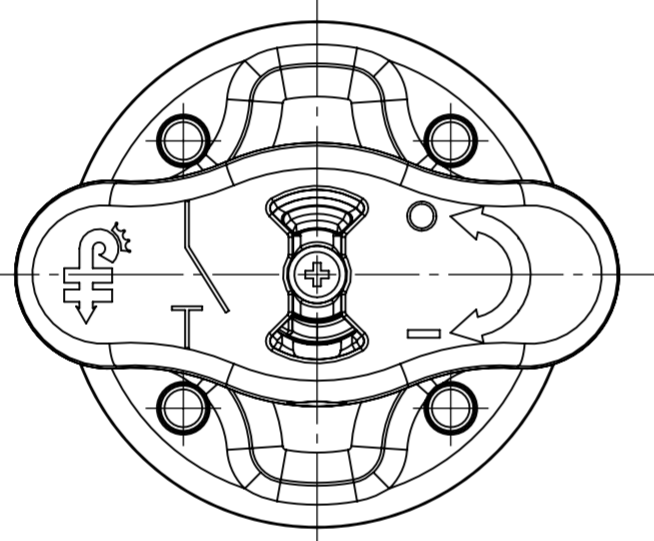
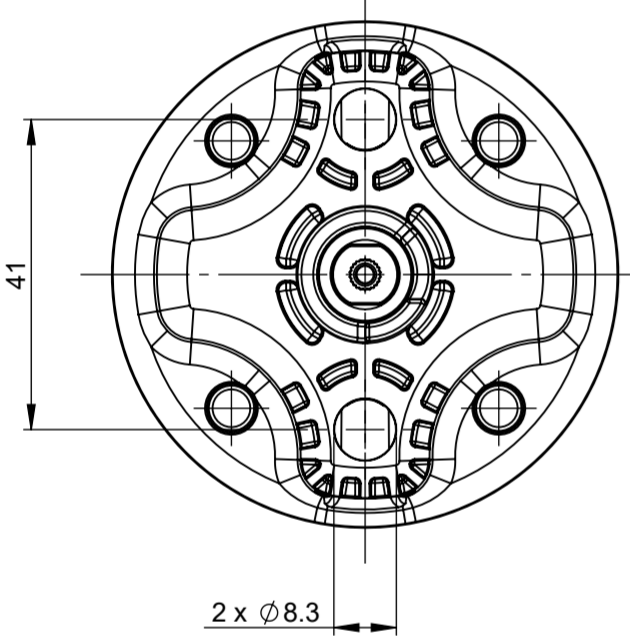

STATE OF SUPPLY: OFF POSITION

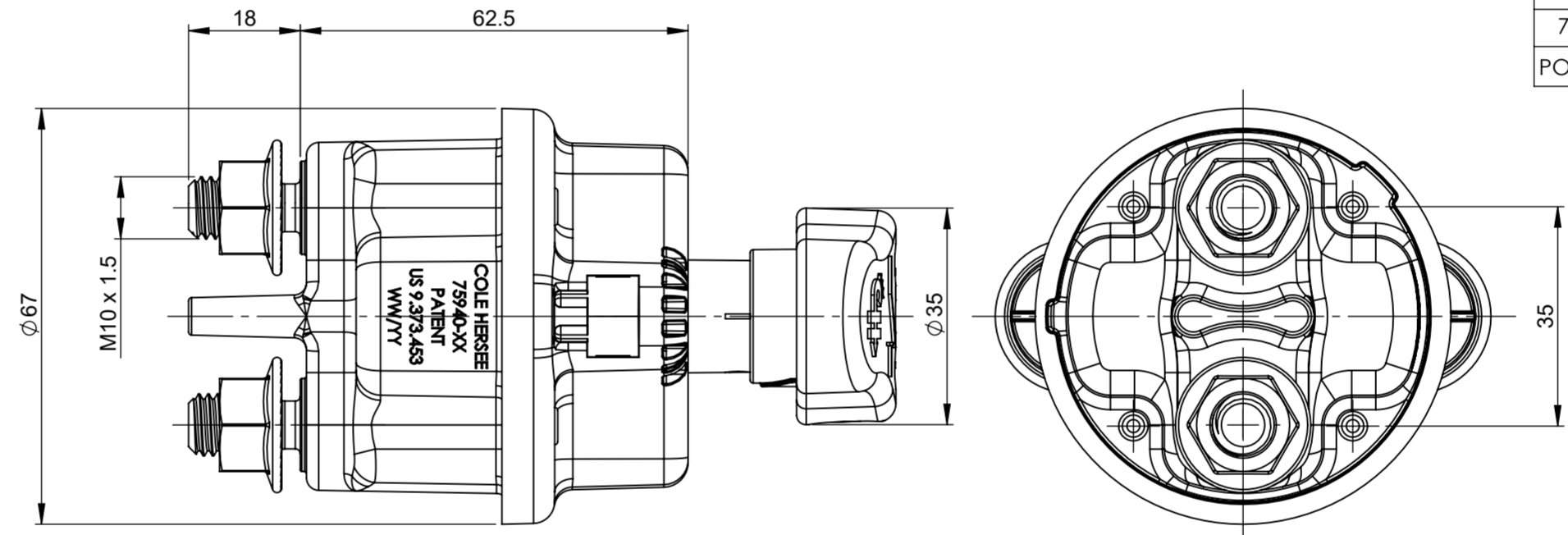

CHARACTERISTICS
 OPERATING TEMPERATURE: -40°C to +85°C.
 MAXIMUM CONTINUOUS CURRENT ON MAIN CONTACT:
 - 200A WITH 90MM2 CABLES;
 - 300A WITH 120MM2 CABLES.
 MAXIMUM PEAK CURRENT ON MAIN CONTACT:
 - 500A FOR 60S AND 1000A FOR 15SEC.
 ANGLE AT WHICH IT DOES SWITCH ON: >25°.
 VOLTAGE RANGE: 9V TO 32V.
 NUMBER OF MECHANICAL AND ELECTRICAL OPERATIONS: 5000.

INSTRUCTIONS
 TORQUE FOR M10 CONNECTION: 18±2NM.
 TORQUE FOR M8 MOUNTING SCREW: 14±2NM.
 THE HANDLE SCREW TO BE SCREWED DOWN TO THE END WITH A TORQUE OF 0,6±0,2NM.
 WALL THICKNESS: 0,8MM TO 8,5MM.

ELECTRICAL DIAGRAM

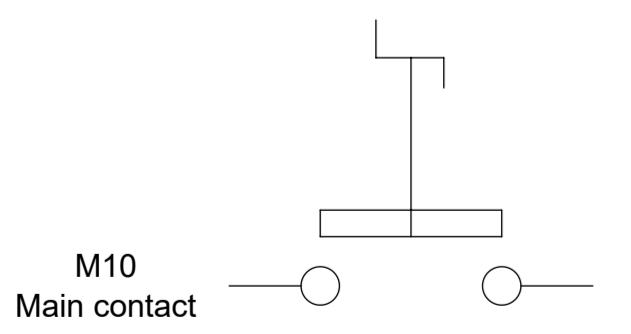

FIXING HOLES

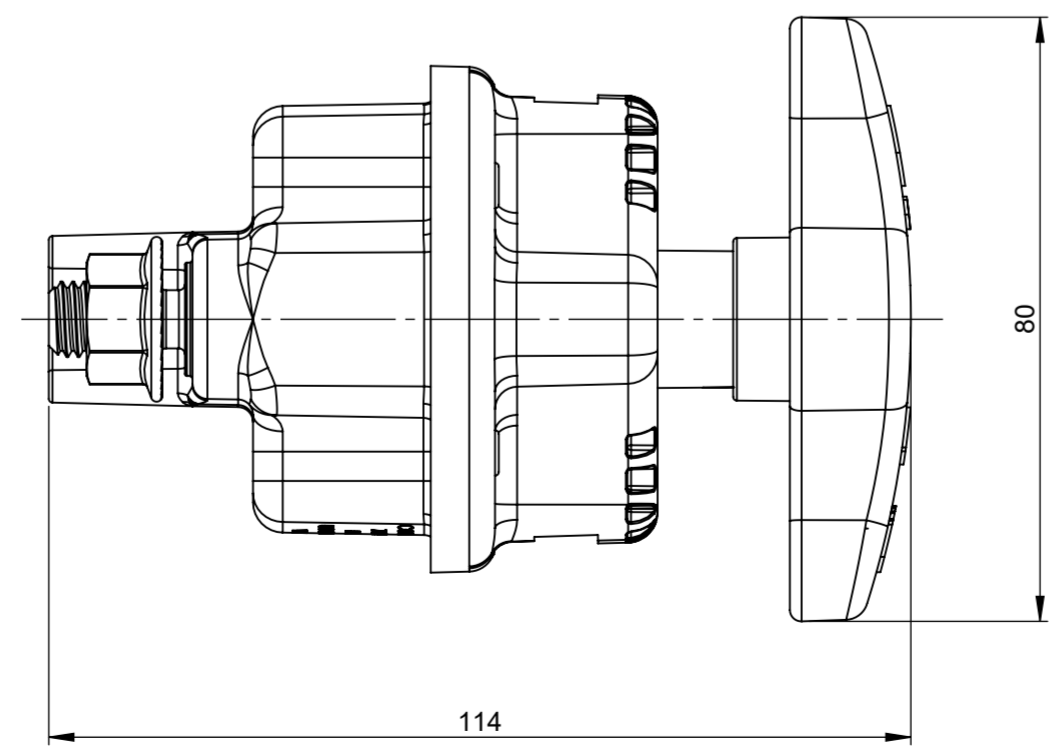
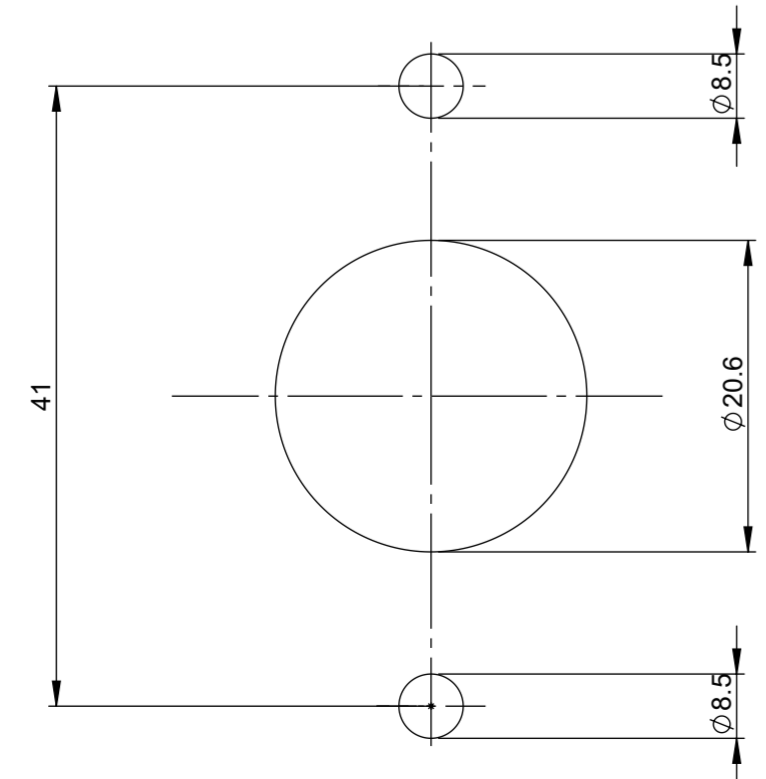

DIMENSIONS AND TOLERANCES IN MILLIMETERS, DEFINED ACCORDING TO ISO 1101-2017.				
linear dimensions				
0,5 3	>3 6	>6 30	>30 120	
±0,1	±0,1	±0,2	±0,3	
angle (for range of lengths)				
up to 10	>10 50	>50 120	>120 400	
±1°	±0°'30"	±0°'20"	±0°'10"	
●	FIT/ FUNCTION CRITICAL CHARACTERISTICS SYMBOL			
<S>	SAFETY/ COMPLIANCE CRITICAL CHARACTERISTICS SYMBOL			
CPK	DENOTES CPK DIMENSIONS MINIMUM CPK VALUE			
ST	DENOTES A CHARACTERISTIC THAT PROVIDES AN INDICATION OF PROCESS PERFORMANCE. PROCEDURE FOR MEASUREMENT AND TRACKING TO BE DEFINED IN LITTELFUSE INSPECTION INSTRUCTIONS			
CP	DENOTES CP DIMENSIONS. MINIMUM CP VALUE MUST BE WITHIN THE DIMENSIONAL LIMITATIONS SHOWN ON DRAWING AND INITIALLY LOCATED TO ALLOW FOR MAXIMUM TOOL LIFE			
NAME	DATE	Littelfuse Expertise Applied Answers Delivered		
DRAWN	T. Bianchin			7 Nov 2023
CHECKED	-			-
FORM NO. CVP-PE40-0013 REV A		TITLE		
FIRST ANGLE PROJECTION		MASTER DISCONNECT SWITCH		
SIZE	DWG. NO.	OUTLINE	REV.	
A2	OL-75940	CHART	A	
DO NOT SCALE DRAWING		SCALE 1:1	SHEET 1 OF 1	