

THIS DRAWING AND THE INFORMATION CONTAINED WITHIN IT ARE CONFIDENTIAL AND MAY NOT BE COPIED OR DISCLOSED WITHOUT THE WRITTEN PERMISSION OF LITTELFUSE.

PART NUMBER	A	B	THREAD	THREAD LENGTH
908-066	6.0	7.8	M6X1.0	16.0
908-067	6.0	7.8	M8X1.25	16.0
908-068	8.0	9.8	M10X1.5	16.0

REVISIONS				
ZONE	REV.	DESCRIPTION	DATE	APPROVED
	A	PCO#5300103. INITIAL RELEASE. DSILVA.	10/4/2022	L.ARGIL

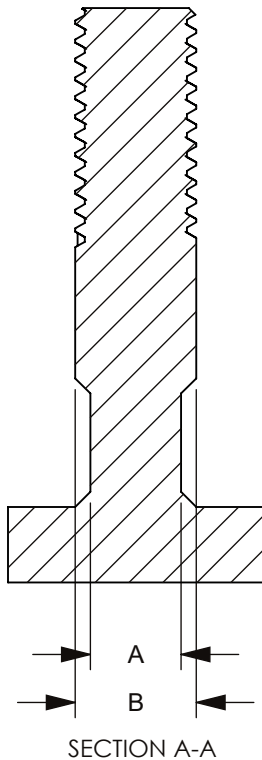
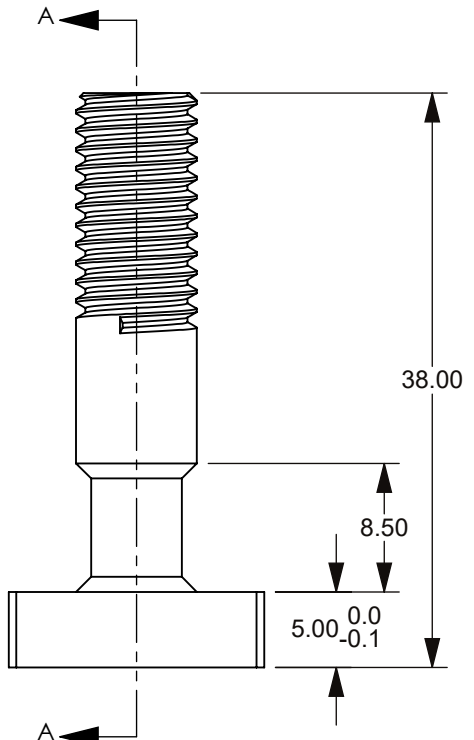
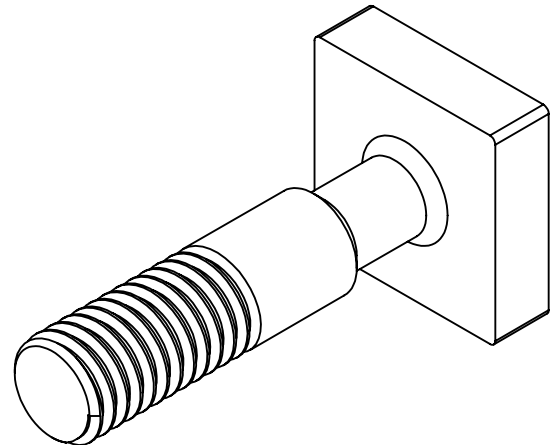
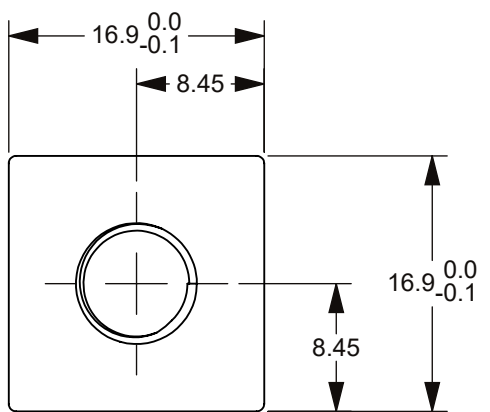

NOTES:
 1. MATERIAL: STEEL, FINISH: PLATED

NO.	COMPONENT NO.	COMPONENT NAME	QTY	U
TOLERANCES UNLESS OTHERWISE SPECIFIED (REF. ISO 2768-FH)				
.5 to 3	>3 to 6	>6 to 30	>30 to 120	>120 to 400
±0.05	±0.05	±0.10	±0.15	±0.20
				ANGLE
				NONE

DIMENSIONS ARE SHOWN IN MILLIMETERS. DIMENSIONS AND TOLERANCES ARE DEFINED ACCORDING TO ANSI/ASME Y14.5-1994.

PER CHI-NPD20-0008 PROCEDURE

- FIT/ FUNCTION CRITICAL CHARACTERISTICS
- <S> SAFETY/ COMPLIANCE CRITICAL CHARACTERISTICS SYMBOL
- CPK DENOTES CPK DIMENSIONS MINIMUM CPK VALUE
- ST DENOTES A CHARACTERISTIC THAT PROVIDES AN INDICATION OF PROCESS PERFORMANCE. PROCEDURE FOR MEASUREMENT AND TRACKING TO BE DEFINED IN LITTELFUSE INSPECTION INSTRUCTIONS
- CP DENOTES CP DIMENSIONS. -MINIMUM CP VALUE MUST BE WITHIN THE DIMENSIONAL LIMITATIONS SHOWN ON DRAWING AND INITIALLY LOCATED TO ALLOW FOR MAXIMUM TOOL LIFE

NAME	DATE	<p>Littelfuse Expertise Applied Answers Delivered</p>
DRAWN DSILVA	7/20/2022	
CHECKED -	-	TITLE STUD FOR ZCASE FUSE BOX
-	-	
FORM NO: CVP-PE40-0003 REV B		SIZE B
THIRD ANGLE PROJECTION		
DO NOT SCALE DRAWING	SCALE 2:1	DWG. NO. OL-908-066
		REV. A
		SHEET 1 OF 1