

REVISIONS				
ZONE	REV.	DESCRIPTION	DATE	APPROVED
	A	GCF#524853 INITIAL RELEASE	NOV./10/2021	D. ZHANG

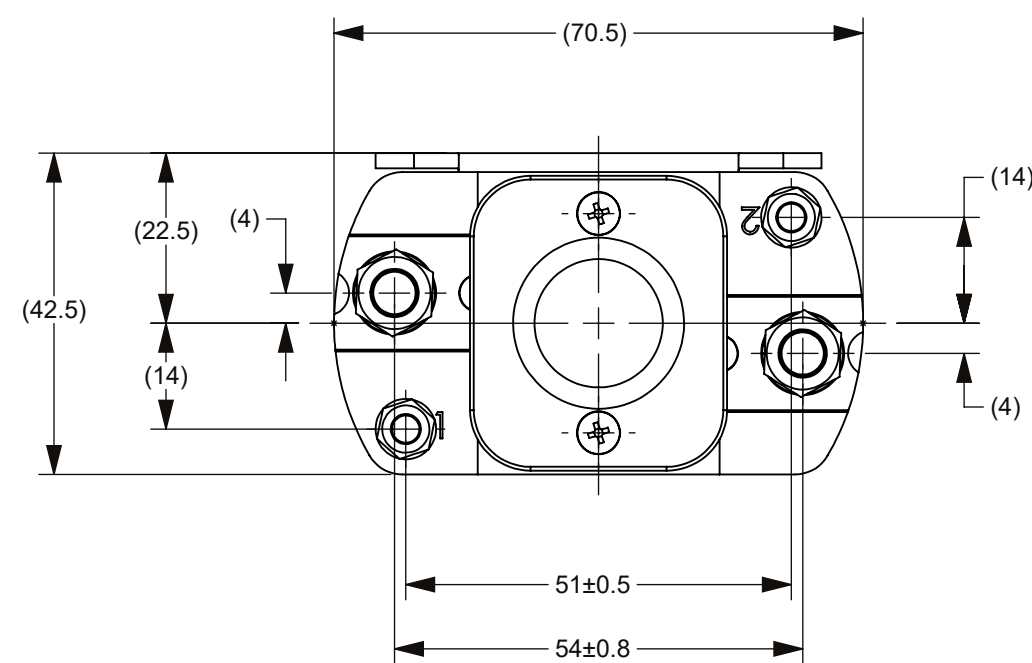

CIRCUIT SCHEMATIC DIAGRAM

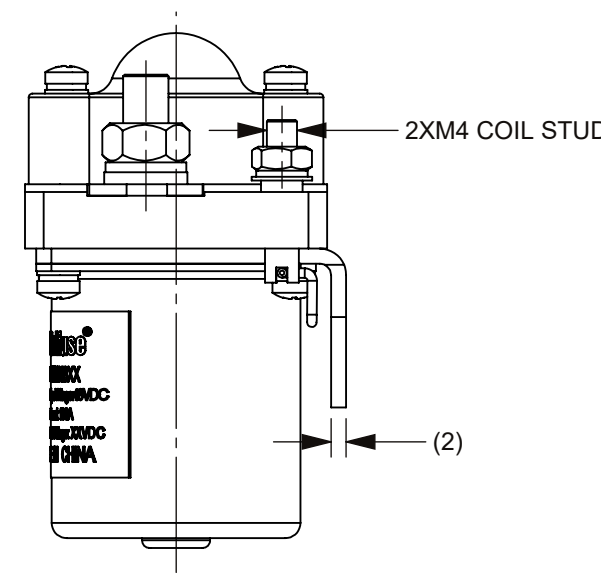
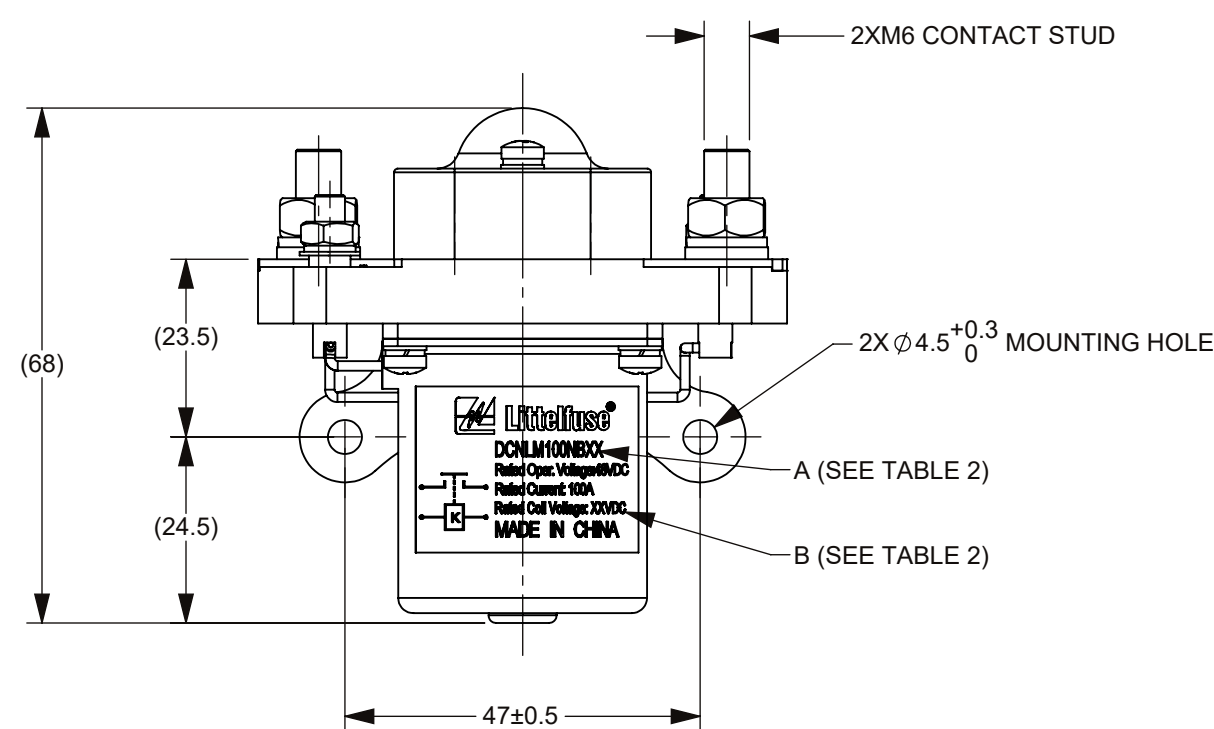
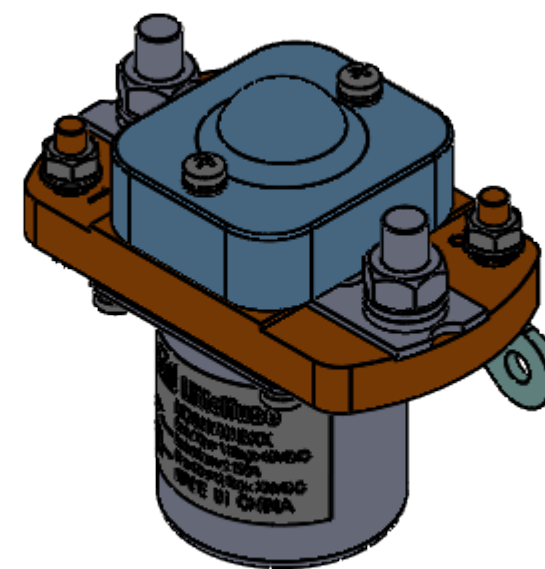
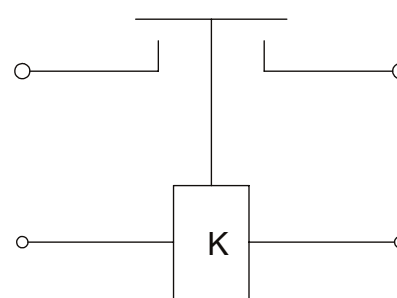

TABLE 1: TECHNICAL PARAMETERS

ITEM	PARAMETER			
	DCNLM100NB12	DCNLM100NB24	DCNLM100NB48	
RATED COIL VOLTAGE	12V DC	24V DC	48V DC	
HOLD POWER	MAX 6W			
OPERATING VOLTAGE IN COLD STATE AT (20±5)°C	PICKUP	MAX 8.4V DC	MAX 16.8V DC	MAX 33.6V DC
	RELEASE	MIN 1V DC	MIN 1.9V DC	MIN 3.8V DC
OPERATE TIME	MAX 30ms			
RELEASE TIME	MAX 30ms			
BOUNCE TIME	MAX 7ms			
RATED CONTACT VOLTAGE	48V DC			
MAXIMUM CONTACT VOLTAGE	60V DC			
RATED CONTACT CURRENT	100A			
CONTACT VOLTAGE DROP	≤80mV@100 A			
LIMIT BREAKING ABILITY	4le/5ms,1CYCLES			
DIELECTRIC STRENGTH	1000V AC, 50Hz,1min., LEAKAGE CURRENT ≤1 mA			
INSULATION RESISTANCE	≥50MΩ@500VDC			
ELECTRIC LIFE	10000 CYCLES			
MECHANICAL LIFE	100,000 CYCLES			
WORKING DUTY	CONTINUOUS			

NOTES:

- ALL SIZES ARE FOR REFERENCE ONLY.
- MATERIALS AND FINISH:
  - 2.1 BASE: THERMOSETTING PLASTIC, UL94V-0.
  - 2.2 CONTACTS: SILVER ALLOY.
  - 2.3 COIL STUD: COPPER ALLY, SILVER PLATED.
- PRODUCT TECHNICAL PARAMETERS: SEE TABLE 1.
- PRODUCT AND NAMEPLATE(THE CHARACTER CONTENT AT "A" AND "B") CONFIGURATION SEE TABLE 2.
- CONTACT ARRANGEMENT: SPST-NO.
- CONNECTION STUD: M6 STUD, RECOMMENDED TORQUE 4 N·m ~ 6 N·m; M4 STUD, RECOMMENDED TORQUE 1.7 N·m ~ 2.5 N·m.
- MOUNTING: M4 BOLT, RECOMMENDED TORQUE 1.7 N·m ~ 2.5 N·m.

TABLE 2 P/N AND CONFIGURATION

P/N	"A"	"B"
DCNLM100NB12	DCNLM100NB12	Rated Coil Voltage: 12VDC
DCNLM100NB24	DCNLM100NB24	Rated Coil Voltage: 24VDC
DCNLM100NB48	DCNLM100NB48	Rated Coil Voltage: 48VDC

DIMENSIONS ARE SHOWN IN MILLIMETERS. DIMENSIONS AND TOLERANCES ARE DEFINED ACCORDING TO ANSI/ASME Y14.5-1994.

●	FTI/ FUNCTION CRITICAL CHARACTERISTICS
<S>	SAFETY/ COMPLIANCE CRITICAL CHARACTERISTICS SYMBOL
CPK	DENOTES CPK DIMENSIONS MINIMUM CPK VALUE
(ST)	DENOTES A CHARACTERISTIC THAT PROVIDES AN INDICATION OF PROCESS PERFORMANCE PROCEDURE FOR MEASUREMENT AND TRACKING TO BE DEFINED IN LITTELFUSE INSPECTION INSTRUCTIONS
CP	DENOTES CP DIMENSIONS. -MINIMUM CP VALUE MUST BE WITHIN THE DIMENSIONAL LIMITATIONS SHOWN ON DRAWING AND INITIALLY LOCATED TO ALLOW FOR MAXIMUM TOOL LIFE

NAME	DATE	 Expertise Applied   Answers Delivered
DRAWN V. ZHANG	NOV./10/2021	
CHECKED J. LI	NOV./30/2021	
FORM NO. CVP-PE40-0005 REV B		TITLE
THIRD ANGLE PROJECTION		DCNLM 100A 48V COIL CONTACTOR
DO NOT SCALE DRAWING	SCALE 1:1	REV. A