

REVISIONS				
ZONE	REV.	DESCRIPTION	DATE	APPROVED
	A	GCF#524228 INITIAL RELEASE	JUL./25/2021	D. ZHANG

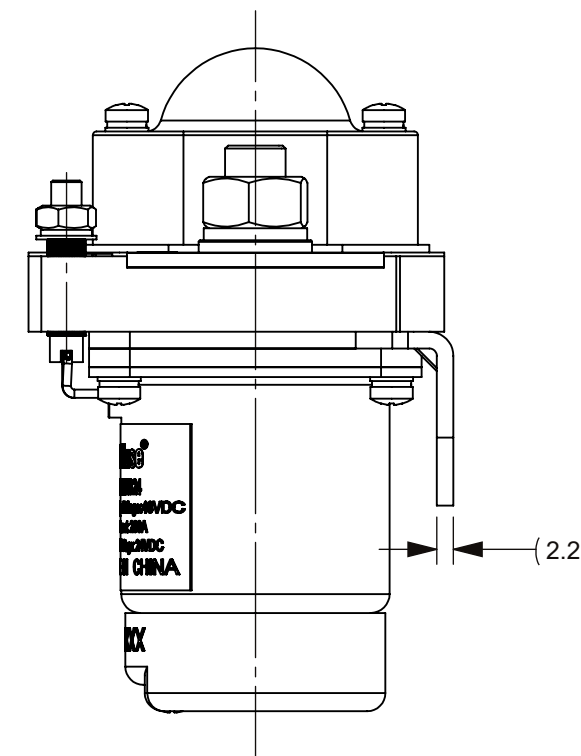

CIRCUIT SCHEMATIC DIAGRAM

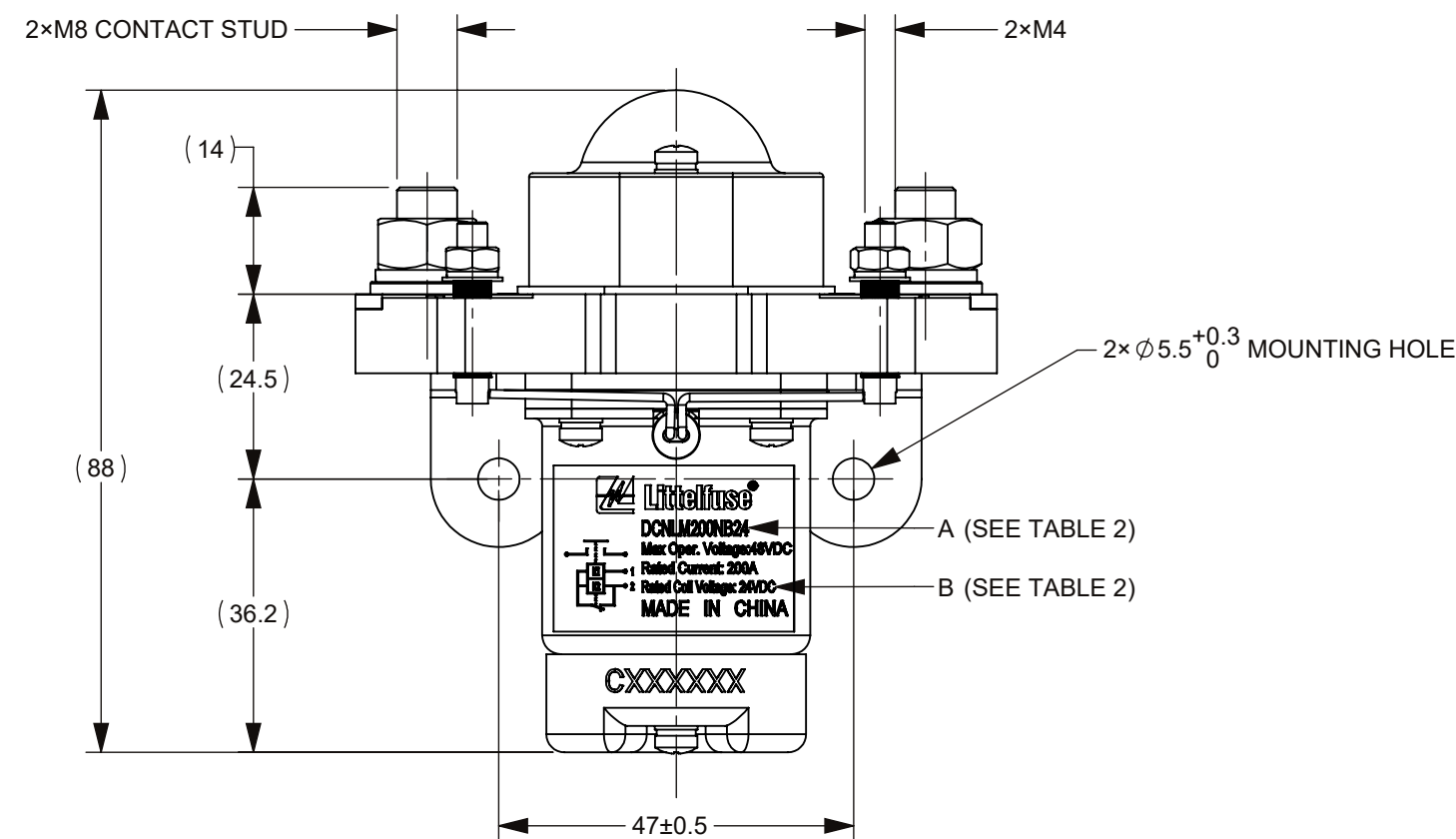
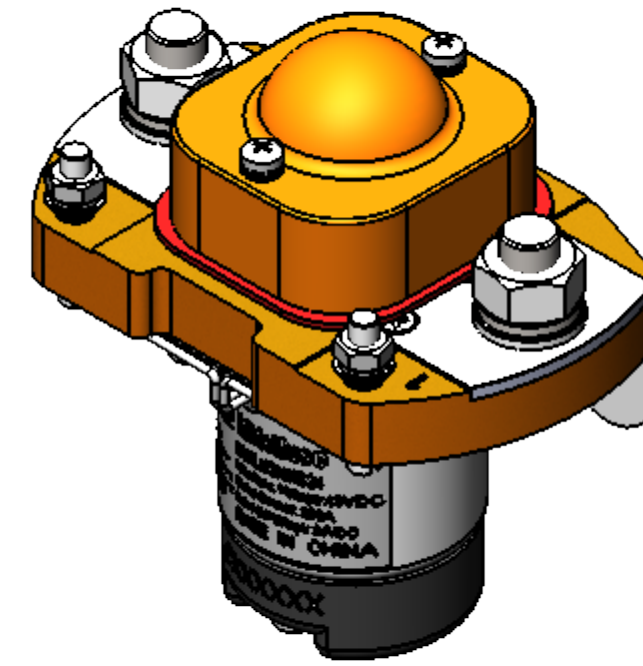
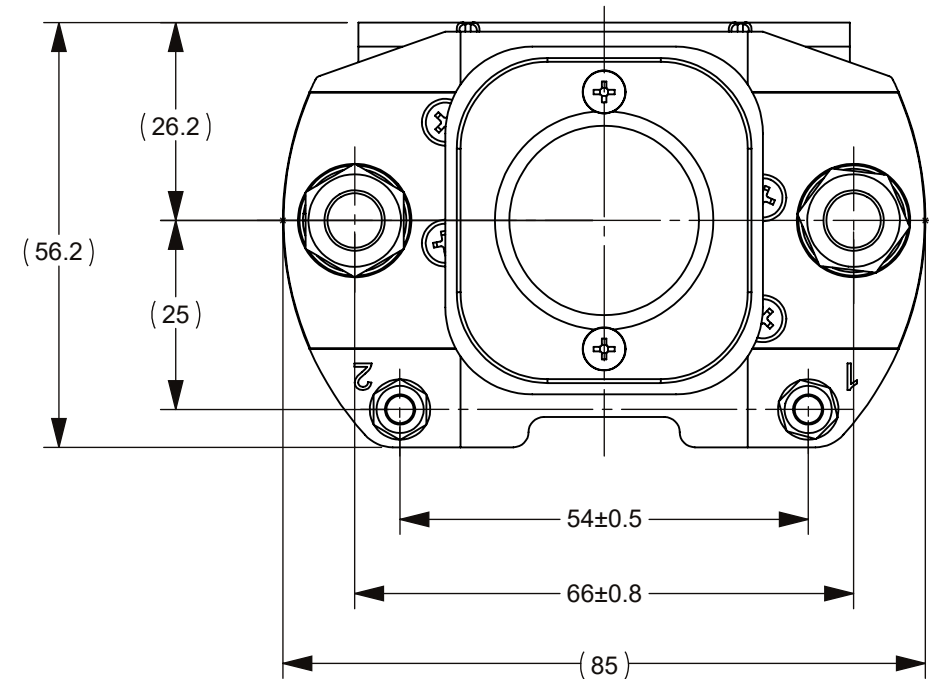
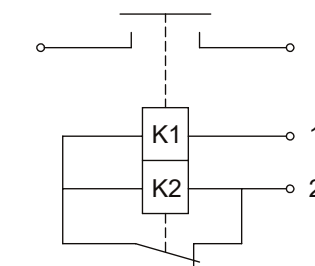

TABLE 1: TECHNICAL PARAMETERS

ITEM	PARAMETER			
	DCNLM200NB12	DCNLM200NB24	DCNLM200NB48	
RATED COIL VOLTAGE	12V DC	24V DC	48V DC	
HOLD POWER	START POWER	MAX 180W		
	MAINTAIN POWER	MAX 9W		
OPERATING VOLTAGE IN COLD STATE AT (20±5)°C	PICKUP	MAX 8.4V DC	MAX 16.8V DC	MAX 33.6V DC
	RELEASE	MIN 1V DC	MIN 2V DC	MIN 4V DC
OPERATE TIME	MAX 40ms			
RELEASE TIME	MAX 20ms			
BOUNCE TIME	MAX 5ms			
RATED CONTACT VOLTAGE	48V DC			
MAXIMUM CONTACT VOLTAGE	60V DC			
RATED CONTACT CURRENT	200A			
CONTACT VOLTAGE DROP	≤50mV@100 A			
LIMIT BREAKING ABILITY	4le/5ms,1CYCLES			
DIELECTRIC STRENGTH	1000V AC, 50Hz,1min., LEAKAGE CURRENT ≤1 mA			
INSULATION RESISTANCE	≥2MΩ@500VDC			
ELECTRIC LIFE	6000 CYCLES			
MECHANICAL LIFE	100,000 CYCLES			
WORKING DUTY	CONTINUOUS			

NOTES:

- ALL SIZES ARE FOR REFERENCE ONLY.
- MATERIALS AND FINISHED:
 - 1 BASE: THERMOSETTING PLASTIC, UL94V-0.
 - 2.2 CONTACTS: SILVER ALLOY.
 - 2.3 COIL STUD: COPPER ALLY, SILVER PLATED.
- PRODUCT TECHNICAL PARAMETERS: SEE TABLE 1.
- PRODUCT AND NAMEPLATE(THE CHARACTER CONTENT AT "A" AND "B") CONFIGURATION SEE TABLE 2.
- CONTACT ARRANGEMENT: SPST-NO.
- CONNECTION STUD: M8 STUD, RECOMMENDED TORQUE 9 N•m ~ 11 N•m; M4 STUD, RECOMMENDED TORQUE 1.7 N•m ~ 2.5 N•m.
- MOUNTING: M5 BOLT, RECOMMENDED TORQUE 4 N•m ~ 5 N•m.

TABLE 2

PRODUCT NUMBER	A	B
DCNLM200NB12	DCNLM200NB12	Rated Coil Voltage: 12VDC
DCNLM200NB24	DCNLM200NB24	Rated Coil Voltage: 24VDC
DCNLM200NB48	DCNLM200NB48	Rated Coil Voltage: 48VDC

DIMENSIONS ARE SHOWN IN MILLIMETERS. DIMENSIONS AND TOLERANCES ARE DEFINED ACCORDING TO ANSIA/SME Y14.5-1994.

●	FTI/ FUNCTION CRITICAL CHARACTERISTICS
<S>	SAFETY/ COMPLIANCE CRITICAL CHARACTERISTICS SYMBOL
CPK	DENOTES CPK DIMENSIONS MINIMUM CPK VALUE
(ST)	DENOTES A CHARACTERISTIC THAT PROVIDES AN INDICATION OF PROCESS PERFORMANCE PROCEDURE FOR MEASUREMENT AND TRACKING TO BE DEFINED IN LITTELFUSE INSPECTION INSTRUCTIONS
CP	DENOTES CP DIMENSIONS. -MINIMUM CP VALUE MUST BE WITHIN THE DIMENSIONAL LIMITATIONS SHOWN ON DRAWING AND INITIALLY LOCATED TO ALLOW FOR MAXIMUM TOOL LIFE

NAME	DATE	 Expertise Applied Answers Delivered
DRAWN: MJ. DAI	JUL./25/2021	
CHECKED: J. LI	JUL./30/2021	TITLE DCNLM 200A 48V CONTACTOR
FORM NO: CVP-PE40-0005 REV B		
THIRD ANGLE PROJECTION		SIZE: C DWG. NO.: OL-DCNLM200NB CHART SCALE: 1:1
DO NOT SCALE DRAWING		
REV. A		SHEET 1 OF 1