

PART NUMBER	COLOR	DIM "A"	DIM "B"	DIM "C"	THREAD "D"	NUT TYPE	STUD CAPS INCLUDED
JBPT0001Z	RED	0.75 (19.05)	0.75 (19.05)	0.75 (19.05)	3/8"-16	DOUBLE NUT	YES
JBPT0002Z	BLACK	0.75 (19.05)	0.75 (19.05)	0.75 (19.05)	3/8"-16	DOUBLE NUT	YES
JBPT0001Z-NC	RED	0.75 (19.05)	0.75 (19.05)	0.75 (19.05)	3/8"-16	HEX FLANGE NUT	NO
JBPT0002Z-NC	BLACK	0.75 (19.05)	0.75 (19.05)	0.75 (19.05)	3/8"-16	HEX FLANGE NUT	NO
JBPT0003Z	RED	1.05 (26.67)	0.65 (16.51)	1.05 (26.67)	1/2"-13	DOUBLE NUT	YES
JBPT0004Z	BLACK	1.05 (26.67)	0.65 (16.51)	1.05 (26.67)	1/2"-13	DOUBLE NUT	YES
JBPT0003Z-NC	RED	1.05 (26.67)	0.65 (16.51)	1.05 (26.67)	1/2"-13	HEX FLANGE NUT	NO
JBPT0004Z-NC	BLACK	1.05 (26.67)	0.65 (16.51)	1.05 (26.67)	1/2"-13	HEX FLANGE NUT	NO
JBPT13802Z2R-NC	RED	1.25 (31.75)	0.75 (19.05)	0.75 (19.05)	3/8"-16	HEX FLANGE NUT	NO
JBPT13802Z2B-NC	BLACK	1.25 (31.75)	0.75 (19.05)	0.75 (19.05)	3/8"-16	HEX FLANGE NUT	NO

LTR	DATE	REVISION	CHK	APD
D	11/4/11	503599ERA-SEE ERN GMB		

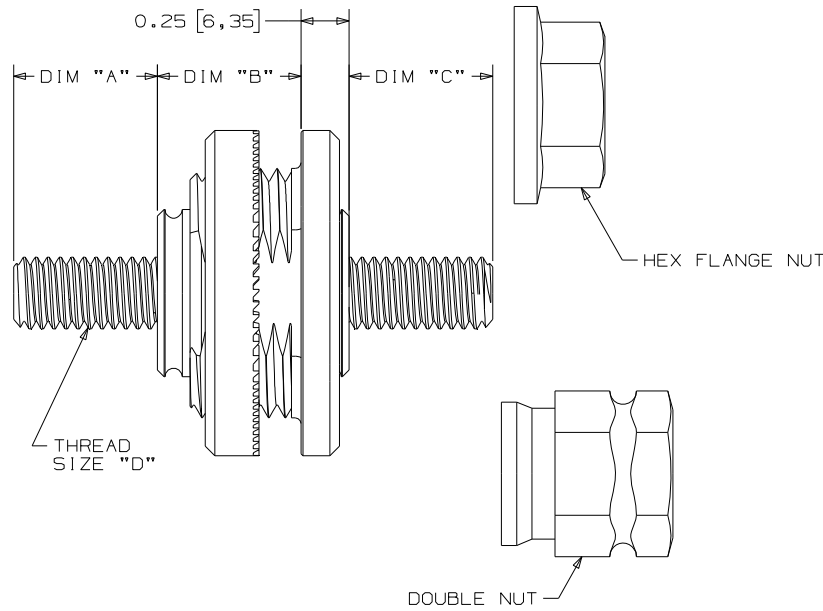
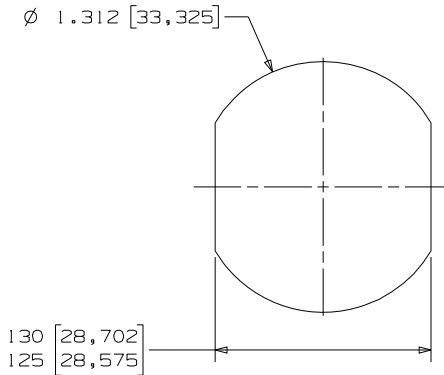

(SHOWN WITHOUT STUD CAPS OR NUTS INSTALLED)

NOTES:

1. ALL DIMENSIONS ARE FOR REFERENCE ONLY.
2. MOUNTING THREADS ARE 1"-11½ NPSM.
3. MAXIMUM MOUNTING TORQUE-10 FT. LBS.
4. MAXIMUM TORQUE ON 3/8-16 STUDS-40 FT.LBS.  
MAXIMUM TORQUE ON 1/2-13 STUDS-40 FT.LBS.  
PART TO BE RESTRAINED DURING TORQUE PROCEDURE
5. PARTS SUPPLIED WITH TWO NUTS & PLASTIC LOCKNUT.  
STUD CAPS SUPPLIED EXCEPT FOR PARTS WITH "-NC" SUFFIX.

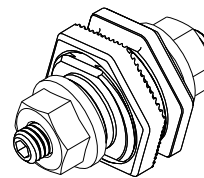

NO	COMPONENT NO	DESCRIPTION	QTY/M	U/M	
BILL OF MATERIAL					
UNLESS OTHERWISE SPECIFIED, DIMENSIONS ARE IN MILLIMETERS. DIMENSIONS IN BRACKETS [ ] ARE INCHES.					
UNLESS OTHERWISE SPECIFIED, DIMENSIONS DO NOT INCLUDE PLATING.					
⊙	DENOTES CRITICAL CHARACTERISTICS.				
CPK	DENOTES CPK DIMENSIONS. -MINIMUM CPK VALUE				
ST	DENOTES A CHARACTERISTIC THAT PROVIDES AN INDICATION OF PROCESS PERFORMANCE. PROCEDURE FOR MEASUREMENT AND TRACKING TO BE DEFINED IN LITTELFUSE INSPECTION INSTRUCTIONS				
CP	DENOTES CP DIMENSIONS. -MINIMUM CP VALUE MUST BE WITHIN THE DIMENSIONAL LIMITATIONS SHOWN ON DRAWING AND INITIALLY LOCATED TO ALLOW FOR MAXIMUM TOOL LIFE				
MATERIAL SPEC					
COPIES TO					
1	9	18			
2	10	19			
3	12	20			
4	13	21			
5	14	23			
6	15	33			
7	16	43			
8	17	53			
FINISH					
DRW	CAD	DATE	03/23/09	SCALE 1.5:1	
CHK		DATE		SUPER DR	
APPD		DATE		FINISH GOOD WT	
GRAMS/PIECE					
TOLERANCES UNLESS OTHERWISE SPECIFIED (REF. ISO 2768-MH)					
DIMENSION	0.5 - 3	3 - 6	6 - 30	30 - 120	120 - 400
TOLERANCE					
3RD ANGLE PROJECTION					
TITLE PASS-THRU JUNCTION BLOCKS 3/8"-16 & 1/2"-13					
Littelfuse		REVISION	DRWG. NO.	OUTLINE	
DES PLAINES, ILLINOIS 60016		D	OL-JBPT0000Z		

CAD GENERATED DRAWING - NO PENCIL CHANGES ALLOWED