

PART NUMBER

OLD45853ZX

REVISION

REV	DATE	DESCRIPTION
A	3/11/24	527585GCP - RELEASE MRY

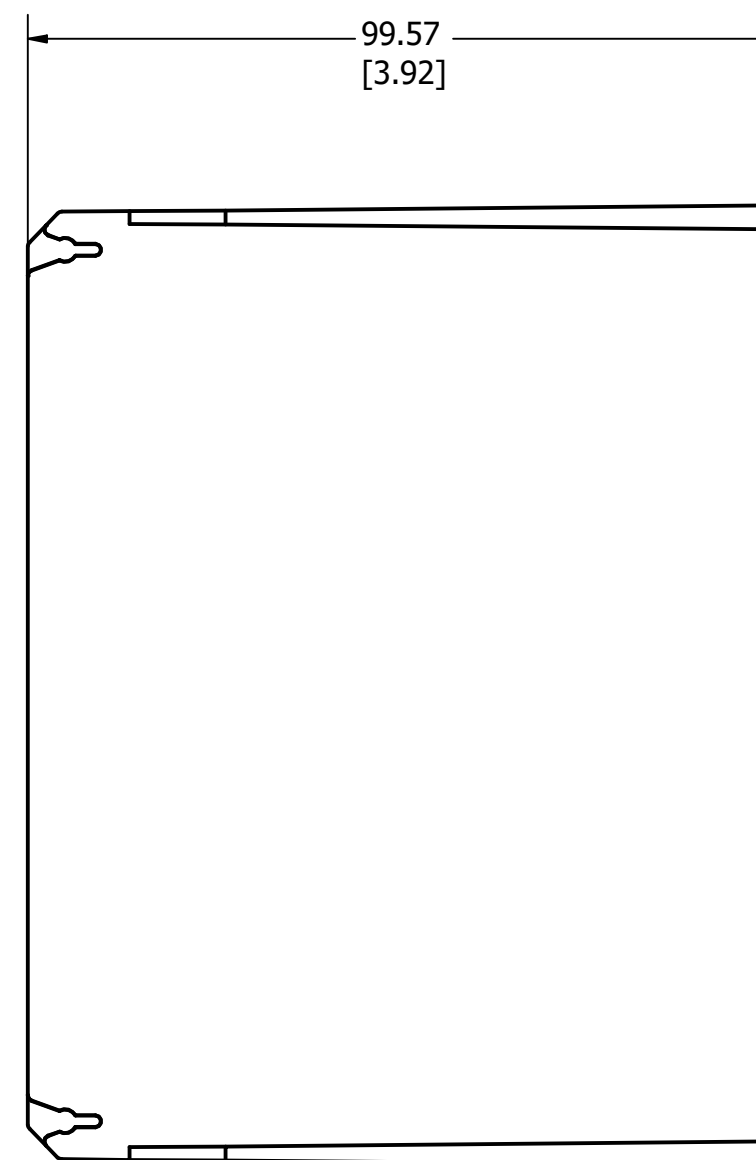
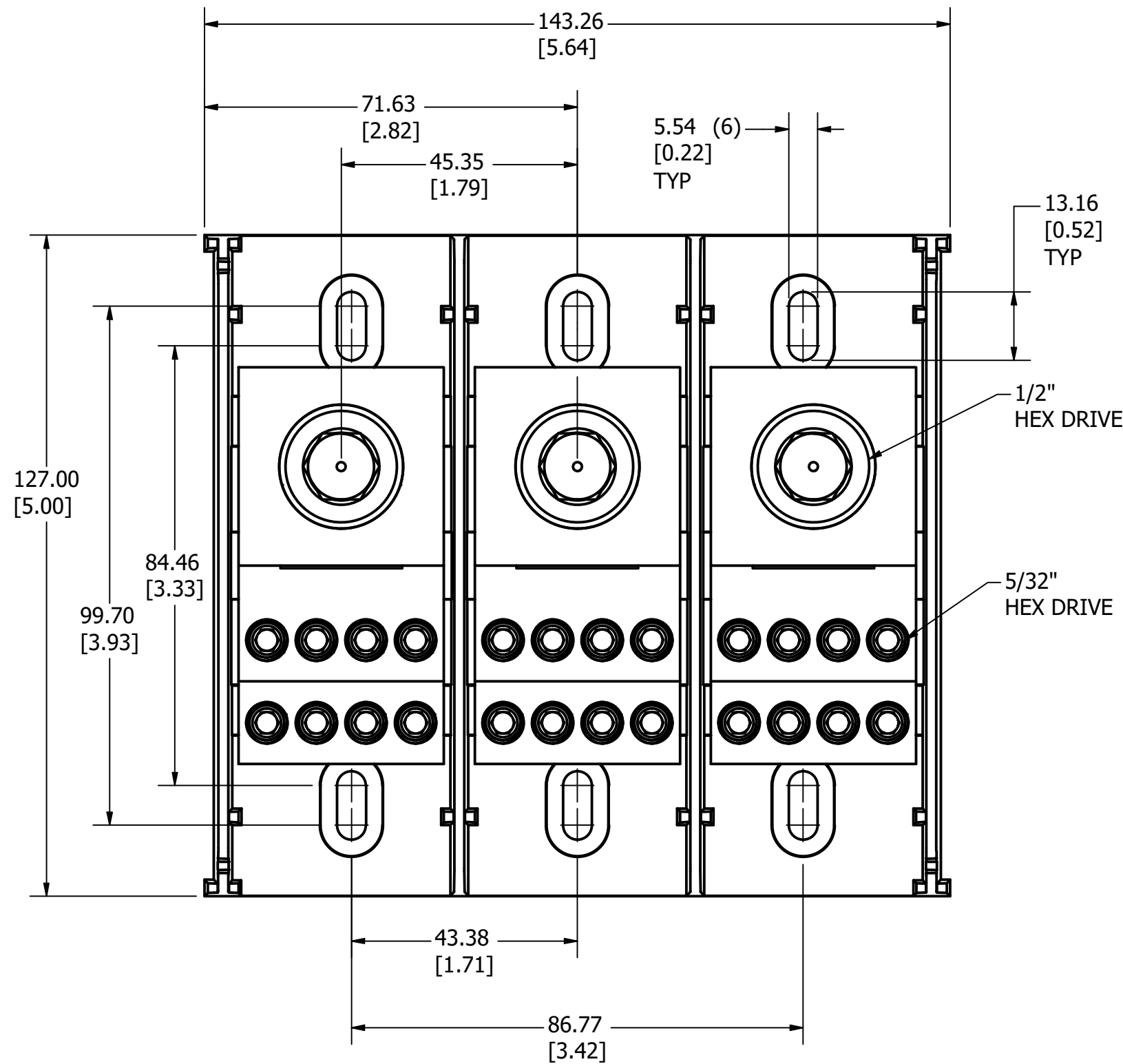

NOTES:

1. AGENCY INFORMATION: cULus - UL LISTED TO UL 1953 EVALUATED TO CSA 22.2
2. MATERIALS: INSULATOR BASE: HIGH IMPACT THERMOPLASTIC
FLAMMABILITY RATING UL94V0
TEMP RATING: -40°C TO 125°C (UL RTI)
CONNECTOR: ALUMINUM, TIN PLATED
LINE TERMINAL SCREWS: ALUMINUM, TIN PLATED
LOAD TERMINAL SCREWS: STEEL, NICKEL PLATED
CONNECTOR MOUNTING SCREWS: STEEL, ZINC PLATED
3. TERMINATION: LINE: ALUMINUM, 600 kcmil - #2
LOAD: COPPER STRANDED, #2 - 14 AWG
SOLID COPPER, #10 - 14 AWG
ALUMINUM STRANDED, #2 - 6 AWG
4. MAXIMUM AMP RATING PER POLE: 420A
BASED ON NEC WIRE RATING CODE, 75°C WIRE
5. TORQUE: LINE: 42.4 N-m (375 lbf-in)
LOAD: #2 AWG: 5.6 N-m (50 lbf-in)
#4 - 6 AWG: 5.1 N-m (45 lbf-in)
#8 AWG: 4.5 N-m (40 lbf-in)
#10 - 14 AWG: 4 N-m (35 lbf-in)
6. MOUNTING: USE #10 FASTENER. TORQUE NOT TO EXCEED 3.4 N-m (30 lbf-in).

TOLERANCE (UNLESS OTHERWISE SPECIFIED):

- 1 PLACE ± 2.5mm [0.10]
- 2 PLACE ± 0.76mm [0.03]
- 3 PLACE ± 0.381mm [0.015]

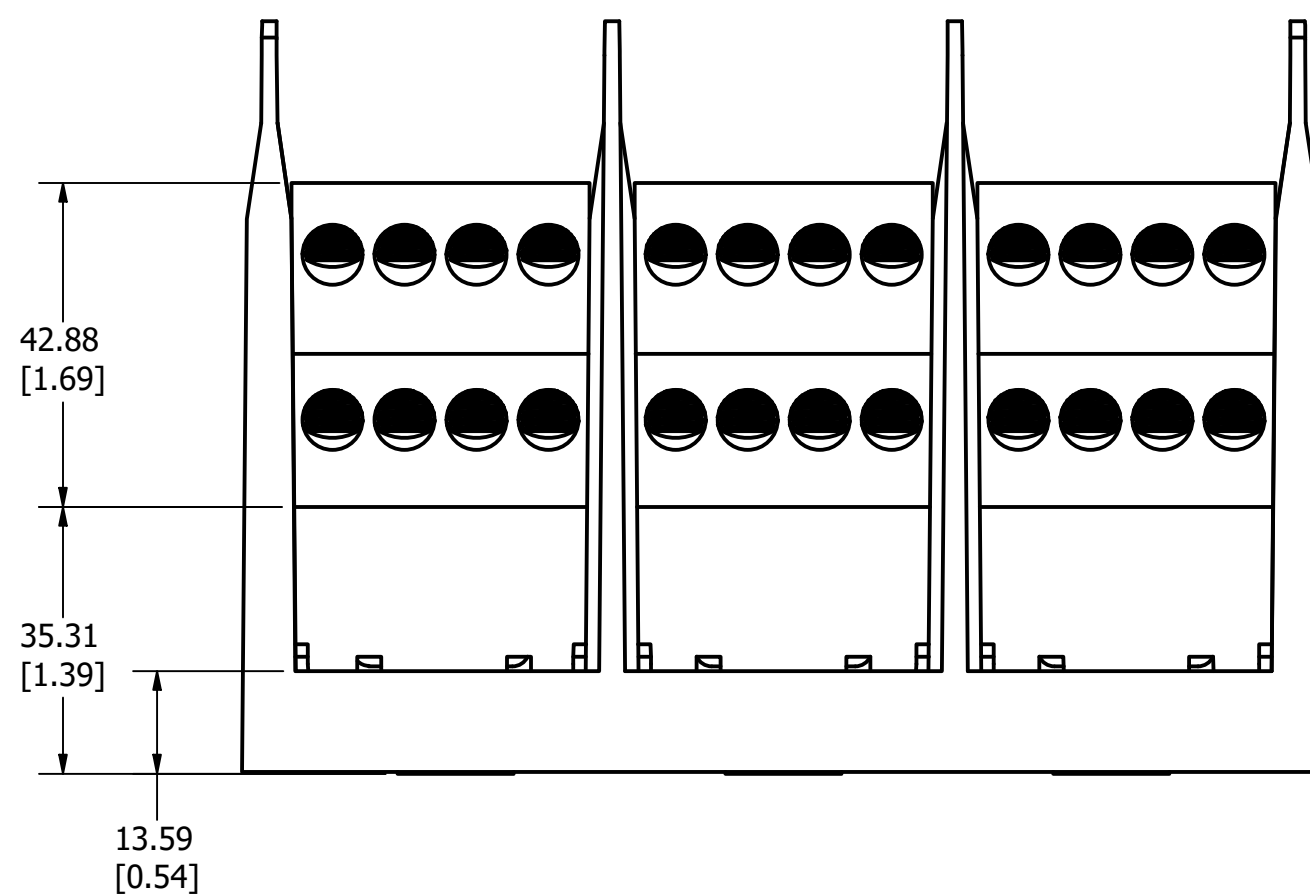

CLASS	Suitable Wire, CU kcmil/AWG		Over-Current Protection Fuse Required						SCCR/RMS Sym. Amps 600V Max
	LINE	LOAD	J	T	RK1	RK5	G	CC	
B-C	600-3/0	2-6	450	450	400	200	60	30	100,000
	600-2	2-10	250	250	200	100	60	30	100,000
	600-2	2-14	125	125	100	30	60	30	100,000
G, H, I	350-3/0	4-6	450	450	400	200	60	30	100,000
	350-2	4-14	125	125	100	30	60	30	100,000
	600-2	2-14			None				10,000

NO	COMPONENT NO	DESCRIPTION	QTY/M	U/M
BILL OF MATERIAL				
<S>		CRITICAL CHARACTERISTIC FOR PART SAFETY/COMPLIANCE		
●		DENOTES CRITICAL CHARACTERISTICS.		
CPK		DENOTES CPK DIMENSIONS, -MINIMUM CPK VALUE		
(ST)		DENOTES A CHARACTERISTIC THAT PROVIDES AN INDICATION OF PROCESS PERFORMANCE. PROCEDURE FOR MEASUREMENT AND TRACKING TO BE DEFINED IN LITTELFUSE INSPECTION INSTRUCTIONS.		
CP		DENOTES CP DIMENSIONS, -MINIMUM CP VALUE MUST BE WITHIN THE DIMENSIONAL LIMITATIONS SHOWN ON DRAWING AND INITIALLY LOCATED TO ALLOW FOR MAXIMUM TOOL LIFE.		C
MATL SPEC		FINISH		
DRW myork	DATE 1/25/2023	SCALE NTS	FINISH GOOD WT GRAMS/PIECE	
UNLESS OTHERWISE SPECIFIED, DIMENSIONS ARE IN MILLIMETERS, DIMENSIONS IN BRACKETS [] ARE INCHES DIMENSIONING AND DO NOT INCLUDE PLATING. TOLERANCING TO BE INTERPRETED IN ACCORDANCE WITH ANSI Y14.5M-1994				
3RD ANGLE PROJECTION				
TITLE DISTRIBUTION BLOCK 600V, 420A, 3 POLE OUTLINE				
CHICAGO, ILLINOIS 60631		REVISION A	DRWG NO. OL-LD45853	SHEET 1 OF 1