

PART NUMBER

OLD45881ZX

REVISION

REV	DATE	DESCRIPTION
A	3/11/24	527585GCP - RELEASE PER EM3406 MRY

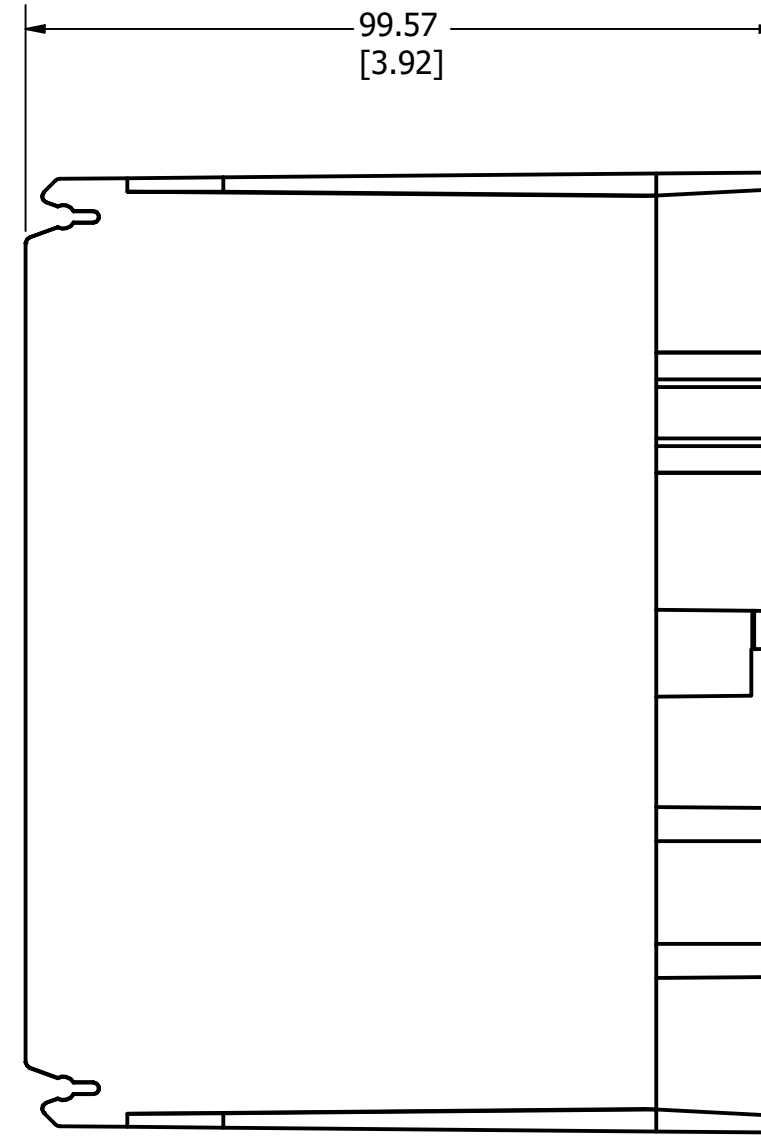
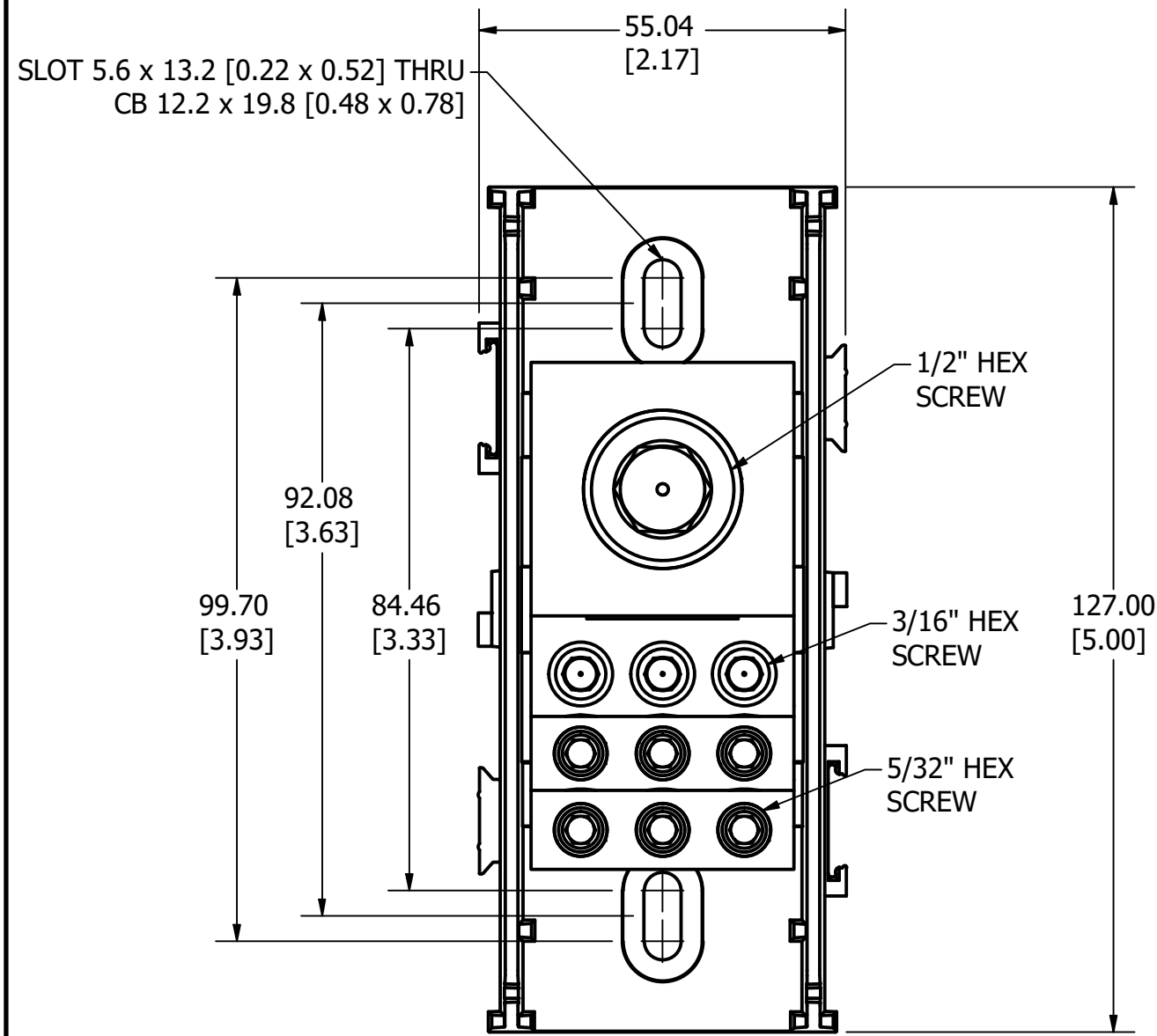

NOTES:

1. AGENCY INFORMATION: cULus - UL LISTED TO UL 1953
EVALUATED TO CSA 22.2
2. MATERIALS: INSULATOR BASE: HIGH IMPACT THERMOPLASTIC
FLAMMABILITY RATING UL94V0
TEMP RATING: -40°C TO 125°C (UL RTI)
CONNECTOR: ALUMINUM, TIN PLATED
TERMINAL SCREWS: 1/2": ALUMINUM, TIN PLATED
3/16": STEEL, NICKEL PLATED
5/32": STEEL, NICKEL PLATED
CONNECTOR MOUNTING SCREWS: STEEL, ZINC PLATED
3. TERMINATION: LINE: ALUMINUM STRANDED, 600 kcmil - #2
LOAD: SOLID COPPER, #10 - 14 AWG
ALUMINUM STRANDED, 1/0 - #6 & #2 - 6 AWG
4. MAXIMUM AMP RATING PER POLE: 420A
BASED ON NEC WIRE RATING CODE, 75°C WIRE
5. TORQUE: LINE: 42.4 N-m (375 lbf-in)
LOAD (TOP 2 ROWS):
1/0 - #1: 13.6 N-m (120 lbf-in)
#2 - 6: 6.8 N-m (60 lbf-in)
#8 - 14: 4.0 N-m (35 lbf-in)
LOAD (BOTTOM ROW):
#2: 5.7 N-m (50 lbf-in)
#4 - 6: 5.1 N-m (45 lbf-in)
#8: 4.5 N-m (40 lbf-in)
#10 - 14: 4.0 N-m (35 lbf-in)
6. MOUNTING: USE #10 FASTENER. TORQUE NOT TO EXCEED
3.4 N-m (30 lbf-in).

TOLERANCE (UNLESS OTHERWISE SPECIFIED):

- 1 PLACE ± 2.5mm [0.10]
- 2 PLACE ± 0.76mm [0.03]
- 3 PLACE ± 0.381mm [0.015]

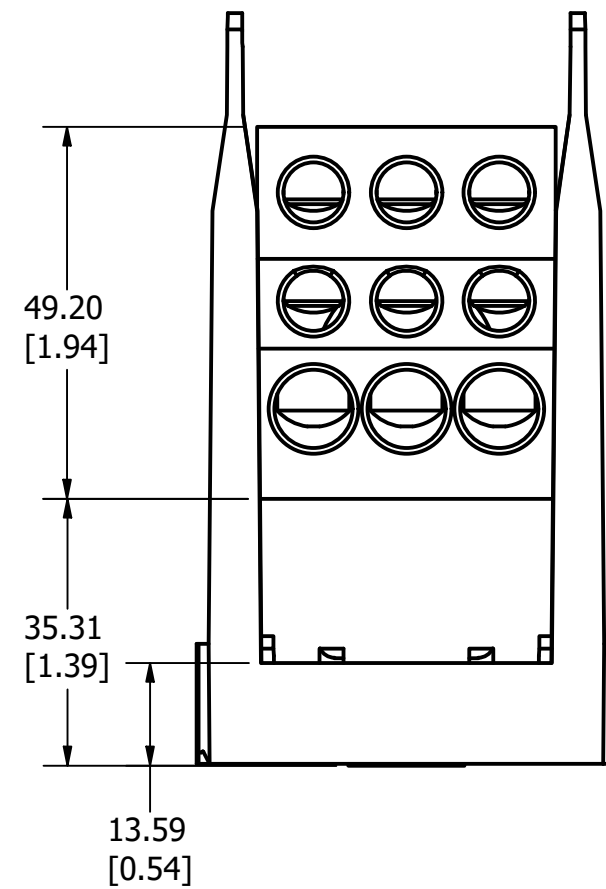

Littelfuse
POWER DISTRIBUTION BLOCK
CAT NO **OLD45881ZX**
LINE TORQUE
600 - 2 cual 375 lbf. in.
LOAD TORQUE
1/0 - 1 cual 120 lbf.in.
2 - 6 cual 40 lbf.in.
8 - 14 cu 35 lbf.in.
LOAD (S) TORQUE
2 cual 50 lbf.in.
4 - 6 cual 45 lbf.in.
8 cu 40 lbf.in.
10 - 14 cu 35 lbf.in.
600V 420A CU7AL

0 79458 31180 8
Made in USA

CLASS	Suitable Wire, CU		Over-Current Protection Fuse Required						SCCR(FBE) Sym. Amps 600V Max	
	LINE	LOAD	J	T	FRL	FRLS	G	CC		
B-C	600 - 3/0	10 - 8 L	500	500	400	200	80	30	100,000	
	600 - 2	10 - 10 L 2 - 10 S	300	300	200	100	80	30	100,000	
G,H,I	350 - 3/0	3 - 8 L	500	500	400	200	80	30	100,000	
	350 - 2	1 - 10 L 4 - 10 S	300	300	200	100	80	30	100,000	
	600 - 2	1/0 - 14	None							10,000

L - LARGE LOAD SIDE HOLE; S - SMALL LOAD SIDE HOLE

PRODUCT LABELS

NO	COMPONENT NO	DESCRIPTION	QTY/M	U/M
BILL OF MATERIAL				
<S>		CRITICAL CHARACTERISTIC FOR PART SAFETY/COMPLIANCE		
●		DENOTES CRITICAL CHARACTERISTICS.		
CPK		DENOTES CPK DIMENSIONS, -MINIMUM CPK VALUE		
(ST)		DENOTES A CHARACTERISTIC THAT PROVIDES AN INDICATION OF PROCESS PERFORMANCE. PROCEDURE FOR MEASUREMENT AND TRACKING TO BE DEFINED IN LITTELFUSE INSPECTION INSTRUCTIONS.		
CP		DENOTES CP DIMENSIONS, -MINIMUM CP VALUE. MUST BE WITHIN THE DIMENSIONAL LIMITATIONS SHOWN ON DRAWING AND INITIALLY LOCATED TO ALLOW FOR MAXIMUM TOOL LIFE.		C
MATL SPEC		FINISH		
DRW myork	DATE 1/25/2023	SCALE NTS	FINISH GOOD WT GRAMS/PIECE	
UNLESS OTHERWISE SPECIFIED, DIMENSIONS ARE IN MILLIMETERS, DIMENSIONS IN BRACKETS [] ARE INCHES DIMENSIONING AND DO NOT INCLUDE PLATING. TOLERANCING TO BE INTERPRETED IN ACCORDANCE WITH ANSI Y14.5M-1994				
3RD ANGLE PROJECTION				
TITLE DISTRIBUTION BLOCK 600V, 420A, 1 POLE OUTLINE				
Littelfuse CHICAGO, ILLINOIS 60631		REVISION A	DRWG NO. OL-LD45881	SHEET 1 OF 1