

NOTE:

- MATERIAL:
 BASE/COVER: NYLON66 - BLACK
 TPA: NYLON66 - BLUE
 SEAL: 30 DURO SILICONE (GREEN)
 FOAM: SILICONE RUBBER, RUST RED
- TORQUE RATING: 5.5-6.5 Nm USING M6 BOLT & LOCK WASHER
- MAX. TOTAL CURRENT @ 23°C IS 100A
 MAX. TOTAL CURRENT @ 85°C IS 70A.
 ALL FUSE MUST NOT EXCEED 70% OF RATED CURRENT.
- OPERATING & STORAGE TEMPERATURE: -40°C TO 85°C
- ASSEMBLY MUST PASS IP67 IEC60529 TESTS.
- COVER MUST WITHSTAND A PULL FORCE OF 15-30N WHEN INSTALLED WITH SEAL AND BASE.
- TERMINAL RETENTION MUST MEET REQUIREMENTS OF USCAR 2 SECTION 5.4.1.3 USING PROPER DELPHI METRI-PACK TERMINALS (SEALED/TANGLSS):
 TERMINAL INSERTION FORCE: 30N MAX. (15N MAX. FOR WIRE SIZE $\leq 1\text{mm}^2$)
 TERMINAL EXTRACTION FORCE: 60N MIN.
 TERMINAL EXTRACTION FORCE WITH TPA INSTALLED: 90N MIN.
- PARTS ARE SHIPPED WITH TPA'S AS BULK AND THE BASE WITH COVER AND SEAL INSTALLED.
- TO BE USED WITH FUSE PULLER 00970032Z.
- THE SEAL SHOULD NOT BE REMOVED NOR DISPLACED DURING TRANSPORT UNTIL IT IS USED FOR PRODUCTION.
- FOAM MUST BE PRESSED INTO BOTTOM OF COVER.
- ADD SILVER/WHITE "XX" MARK ON COVER CORNER.

FEMALE TERMINAL FOR MINI FUSE					LTR	DATE	REVISION	CHK	APD
CABLE SIZE mm ²	FEMALE TERMINAL (DELPHI 280 SEALED)	CABLE DIA	CABLE SEAL (DELPHI 280 METRI-PACK REEL/LOOSE)	COLOR	A	04/12/13	50804BERA-NEW RELEASE	FYUE	
0.50 - 0.35	12084201	1.70 - 1.29	12034365/15324983	DARK RED	B	06/03/13	508417ECA - SEE ECO	FYUE	
1.0 - 0.50	12077411	2.15 - 1.60	12089444/15324985	PURPLE	C	13/Mar/17	517172ECC-CHANGE BASE 868-965 WAS 868-063	FYUE	
3.0 - 2.0	12129493	2.42 - 2.03	12041352/15324984	TAN					
3.0	12077413	2.85 - 2.03	12015284/15324982	GREEN					
		3.49 - 2.81	12015359/15324980	GRAY					
		4.30 - 3.45	12015360/15324981	BLUE					
		CAVITY PLUG	12010300	GREEN					

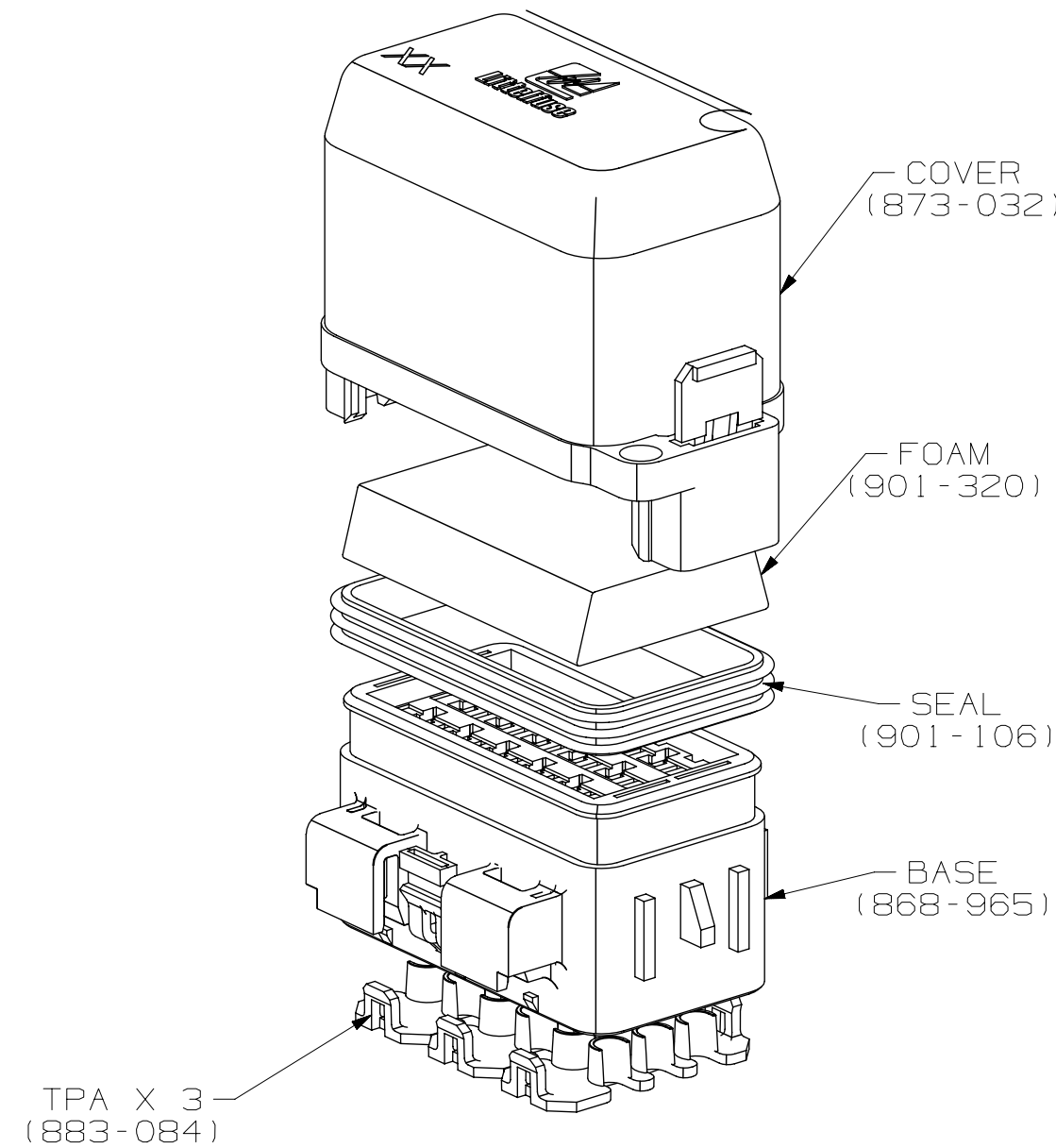

NO	COMPONENT NO	DESCRIPTION	QTY/M	U/M
-				
-				
-				

BILL OF MATERIAL

UNLESS OTHERWISE SPECIFIED, DIMENSIONS ARE IN MILLIMETERS.
 DIMENSIONS IN BRACKETS [] ARE INCHES

UNLESS OTHERWISE SPECIFIED, DIMENSIONS DO NOT INCLUDE PLATING.

⊙ DENOTES CRITICAL CHARACTERISTICS.

CPK DENOTES CPK DIMENSIONS, -MINIMUM CPK VALUE

ST DENOTES A CHARACTERISTIC THAT PROVIDES AN INDICATION OF PROCESS PERFORMANCE. PROCEDURE FOR MEASUREMENT AND TRACKING TO BE DEFINED IN LITTELFUSE INSPECTION INSTRUCTIONS

CP DENOTES CP DIMENSIONS, -MINIMUM CP VALUE MUST BE WITHIN THE DIMENSIONAL LIMITATIONS SHOWN ON DRAWING AND INITIALLY LOCATED TO ALLOW FOR MAXIMUM TOOL LIFE

COPIES TO	MATL SPEC
1 9 18	FINISH
2 10 19	
3 12 20	
4 13 21	DRW FYUE DATE 04/12/13 SCALE 1:1
5 14 23	CHK DATE SUPER DR
6 15 33	APPD DATE FINSH GOOD WT
7 16 43	
8 17 53	GRAMS/PIECE

TOLERANCE	0.5 - 3	3 - 6	6 - 30	30 - 120	120 - 400
	±0.1	±0.1	±0.2	±0.3	±0.5

TOLERANCES UNLESS OTHERWISE SPECIFIED (REF. ISO 2768-mK)

DIMENSION	0.5 - 3	3 - 6	6 - 30	30 - 120	120 - 400
TOLERANCE	±0.1	±0.1	±0.2	±0.3	±0.5

TITLE	REVISION	DRWG. NO.	OUTLINE
18 WAY FUSE HOLDER WITH FOAM	C	01-PDM31004ZXM	

METRIC ASSEMBLY

Littelfuse
 CHICAGO, USA 773-628-1000

REVISION C
 DRWG. NO. 01-PDM31004ZXM
 OUTLINE

CAD GENERATED DRAWING - NO PENCIL CHANGES ALLOWED (REV C)