

- NOTES:
- MATERIAL:
HOUSING: PA66 GF30, BLACK, UL 94 V-0
COVER: PC, COLOR SEE CHART 3 CONFIGURATION
SEAL: SILICON RUBBER, GREEN
TPA: PA66, BLUE, UL94 V-0
 - OPERATING TEMPERATURE RANGE: -40 °C TO +105 °C.
 - MATES WITH TE AMP MCP 2.8 FEMALE TERMINAL, FLR CABLE FOLLOW ISO 6722 CLASS C AND DIN 72511, DETAIL SEE CHART 1 FOR ALLOWED TYPES.
 - 2.8mm BLADES (RATED FOR 40A MAXIMUM), TOTAL MAXIMUM CONTINUOUS CURRENT IS 135A.
 - TPAs AND METAL BRACKET TO BE PACKED ALONG WITH THE HOLDER SEPARATELY IN BULK.
 - OPTIONAL TETHER (890009470) TO BE INSTALLED WITH THE PIN ON COVER AND THE PIN ON BASE.
 - MOUNTING BRACKET (868-964) CAN BE SOLD SEPARATELY, SEE CHART 3 CONFIGURATION.
 - STRAIGHT BRACKET (868-964) CAN BE REPLACED WITH OPTIONAL 30° ANGLE BRACKET (868-068) IF NEEDED.
 - MOUNTING TORQUE 5.5~6.5 Nm, M6 BOLT & LOCK WASHER.
 - IF RELAY(S) IS (ARE) APPLIED, FOAM(S) (901-327) MUST BE FIXED ON THE RELEVANT PLACE(S) IN COVER TO RETAIN THE RELAY(S). RELAY MUST BE INSERTED AT ASSIGNED LOCATION. REFER TO VIEW WITH RELAYS AND FOAMS ON PAGE 3.
 - INGRESS PROTECTION RATING: IP67.

CHART 1: TE AMP MCP 2.8 CONTACT SYSTEM

Wire Size range(mm2)	FLR Insulation Diameter(mm)	Terminal P/N		Single Wire seal	Sealing Plug
		Strip Form	Loose-piece		
0.36-0.5	1.2-1.4	968882	968896	828904-1	828922-1
0.5-1.0	1.4-2.1	968855	968875	828904-2	
1.0-2.5	2.2-3.0	968857	968876	828905-1	

CHART 2: HWB12 ACCESSORY

PART	TETHER	OPTIONAL		NECESSARY IF RELAY APPLIED
		STRAIGHT BRACKET	30° ANGLE BRACKET	FOAM
P/N	890009470	868-964	868-068	901-327
REMARK	SEE NOTE 6	EITHER, SEE CHART 3 CONFIGURATION		ONLY FOR RELAY, SEE NOTE 10 AND VIEW WITH RELAYS AND FOAMS ON PAGE 3

REVISIONS				
ZONE	REV.	DESCRIPTION	DATE	APPROVED
	A	EC #515015 INITIAL RELEASE	11/30/2015	
	B	EC #515383 ADD NEW P/N WITH MOUNTING BRACKET	01/06/2016	
	C	EC #515712 ADD PAGE 2, PAGE 3	03/30/2016	
D1,E3,E4	D	EC #516067 CORRECT THE MISSED SKETCH OF LATCHES IN VIEW WITH STRAIGHT BRACKET	06/28/2016	

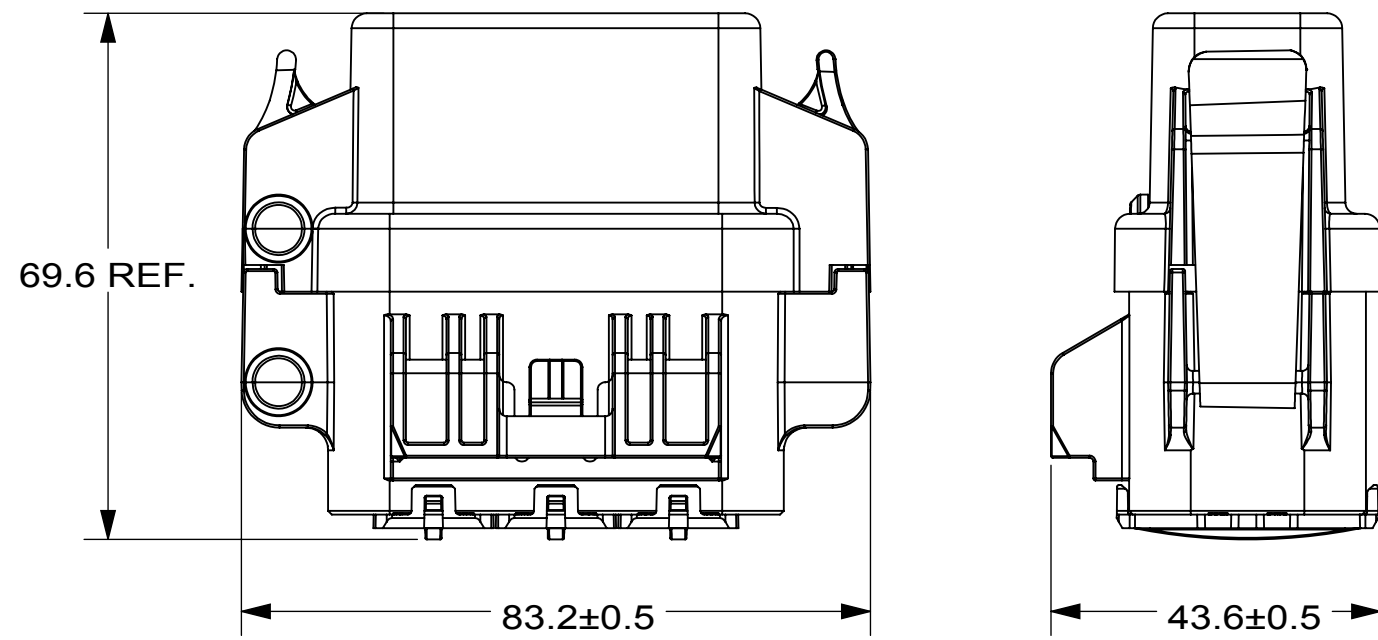

VIEW WITHOUT BRACKET

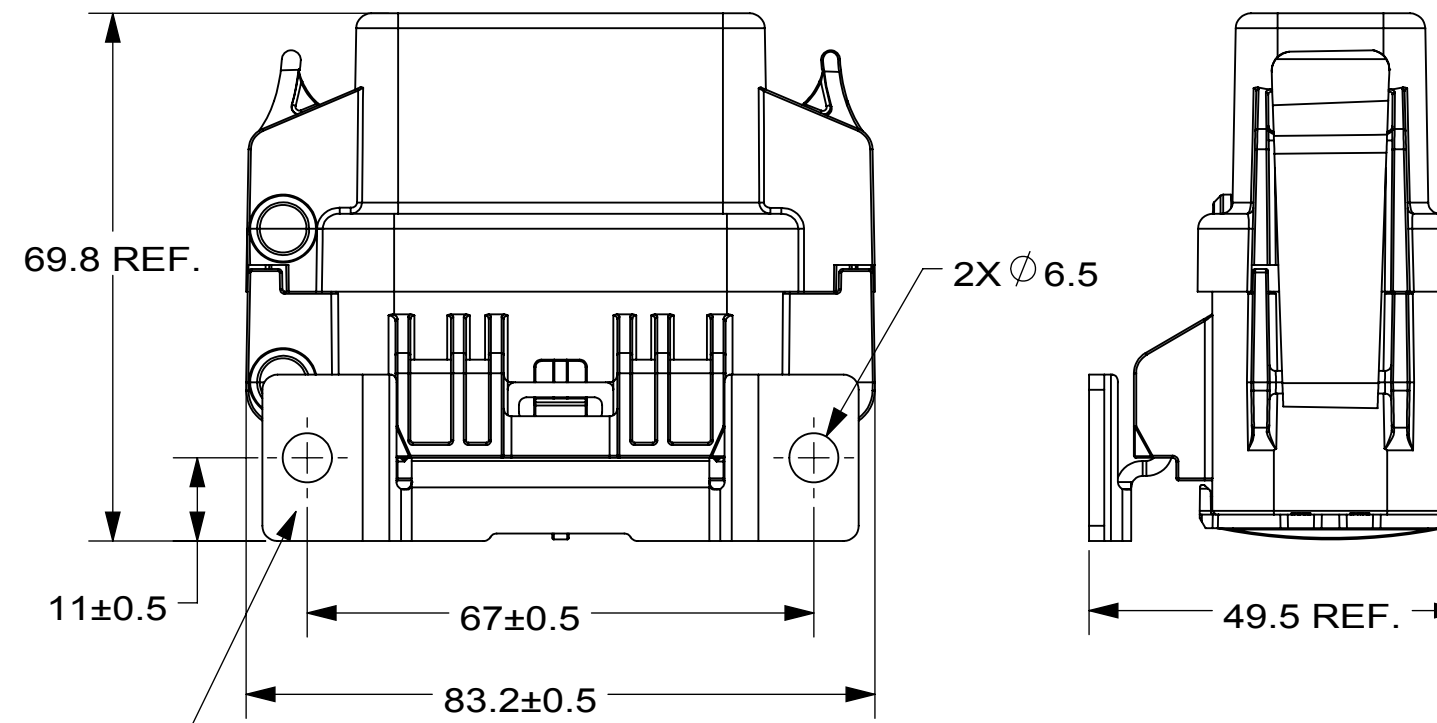

VIEW WITH STRAIGHT BRACKET

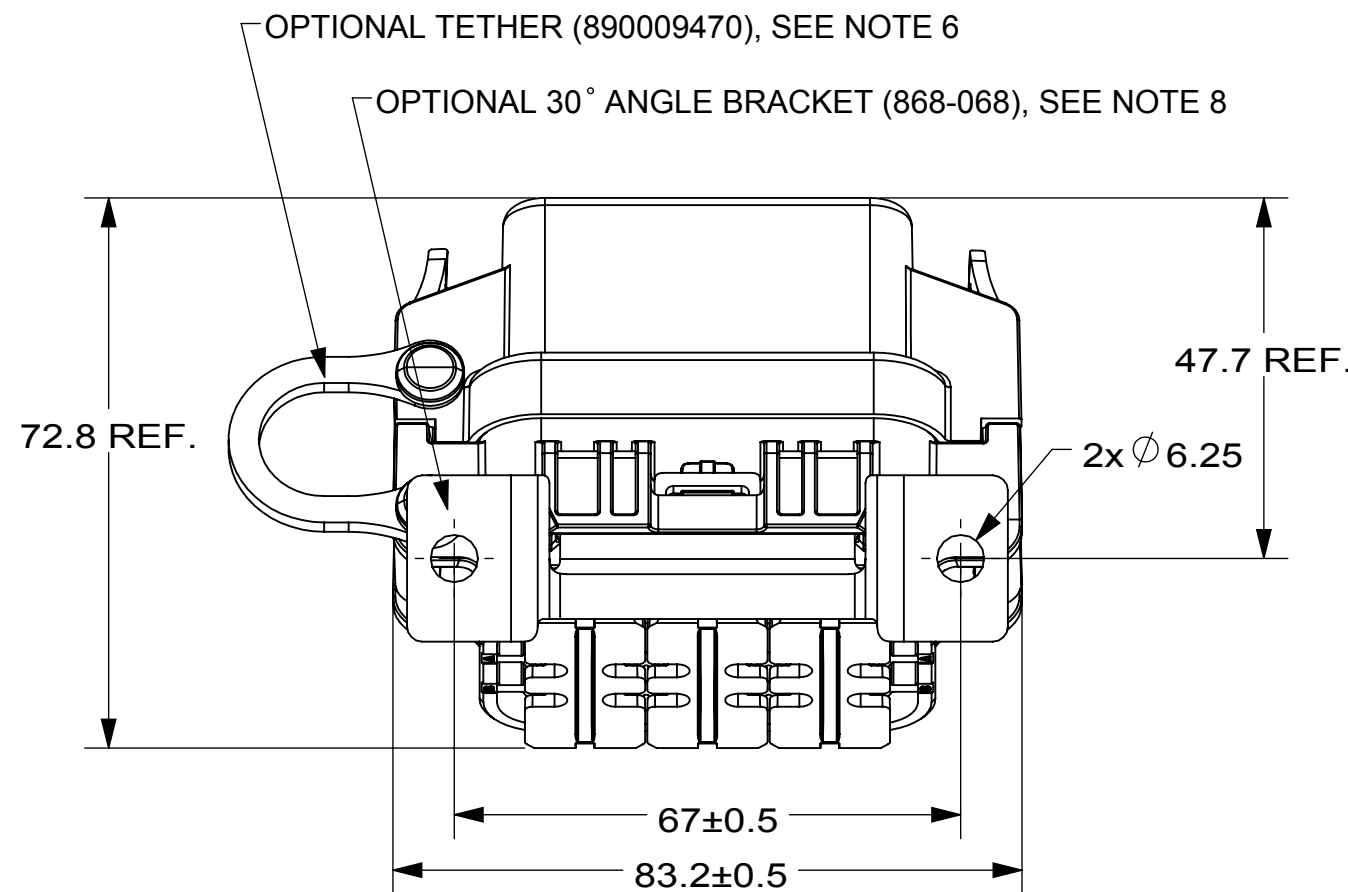
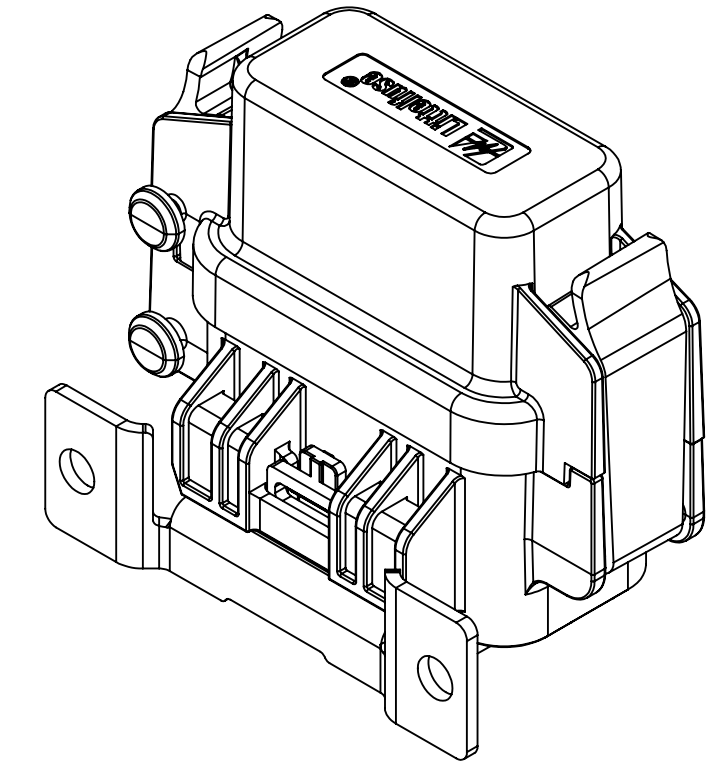

VIEW WITH TETHER AND 30° ANGLE BRACKET

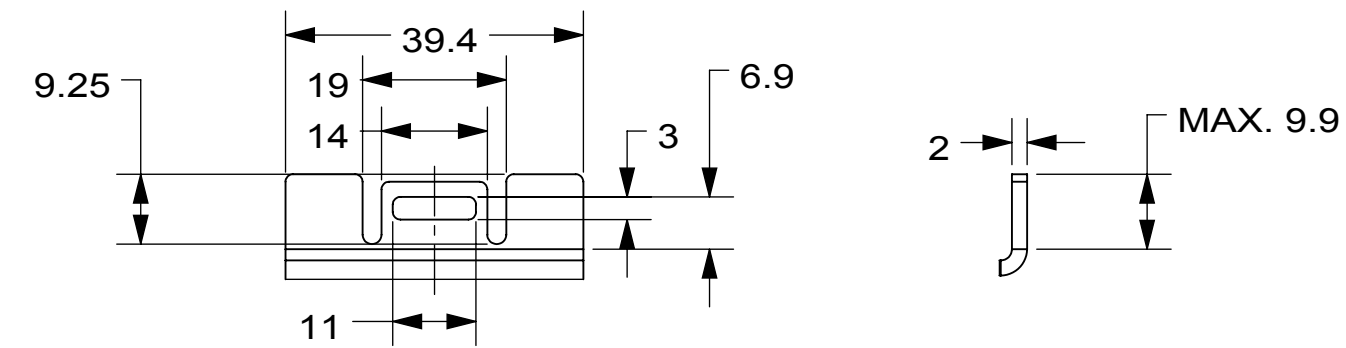

THE LATCHING GEOMETRY OF BRACKET

CHART 3: CONFIGURATION

HWB12 P/N	COVER			STRAIGHT BRACKET (868-964)
	CLEAR	BLACK	REMARK	
PDM33001ZXM	x		UL94 V-2	
PDM33002ZXM		x	UL94 V-0	
PDM33003ZXM	x		UL94 V-2	x
PDM33004ZXM		x	UL94 V-0	x

DIMENSIONS ARE SHOWN IN MILLIMETERS. DIMENSIONS AND TOLERANCES ARE DEFINED ACCORDING TO ANSIS/ASME Y14.5-1994.

- DENOTES PRODUCTS CRITICAL CHARACTERISTICS
- CPK DENOTES CPK DIMENSIONS MINIMUM CPK VALUE
- ST DENOTES A CHARACTERISTIC THAT PROVIDES AN INDICATION OF PROCESS PERFORMANCE PROCEDURE FOR MEASUREMENT AND TRACKING TO BE DEFINED IN LITTELFUSE INSPECTION INSTRUCTIONS
- CP DENOTES CP DIMENSIONS, -MINIMUM CP VALUE MUST BE WITHIN THE DIMENSIONAL LIMITATIONS SHOWN ON DRAWING AND INITIALLY LOCATED TO ALLOW FOR MAXIMUM TOOL LIFE

TOLERANCES UNLESS OTHERWISE SPECIFIED (REF. ISO2768-M)

DIMENSION	UP TO 0.5 - 3	OVER 3 - 6	OVER 6 - 30	OVER 30 - 120	OVER 120 - 400	ANGLE
TOLERANCES	±0.1	±0.1	±0.2	±0.3	±0.5	±1°

NAME: DATE: 10/29/2015
DRAWN: J. LI
CHECKED: E. JIN 03/30/2016

Littelfuse
Executive Office | Anhui 1 Be. Road
No.6 Xinghai Street, Suzhou Industry Park, China
Phone +86 512 6761 3189 Fax +86 512 6761 1489

TITLE: HARD WIRE BOX -12
DWG. NO.: OL-PDM33000ZXM
SCALE: 1:1
SHEET 1 OF 3

THIS DRAWING AND THE INFORMATION CONTAINED WITHIN IT ARE CONFIDENTIAL AND MAY NOT BE COPIED OR DISCLOSED WITHOUT THE WRITTEN PERMISSION OF LITTELFUSE.

REVISIONS				
ZONE	REV.	DESCRIPTION	DATE	APPROVED
		SEE PAGE 1		

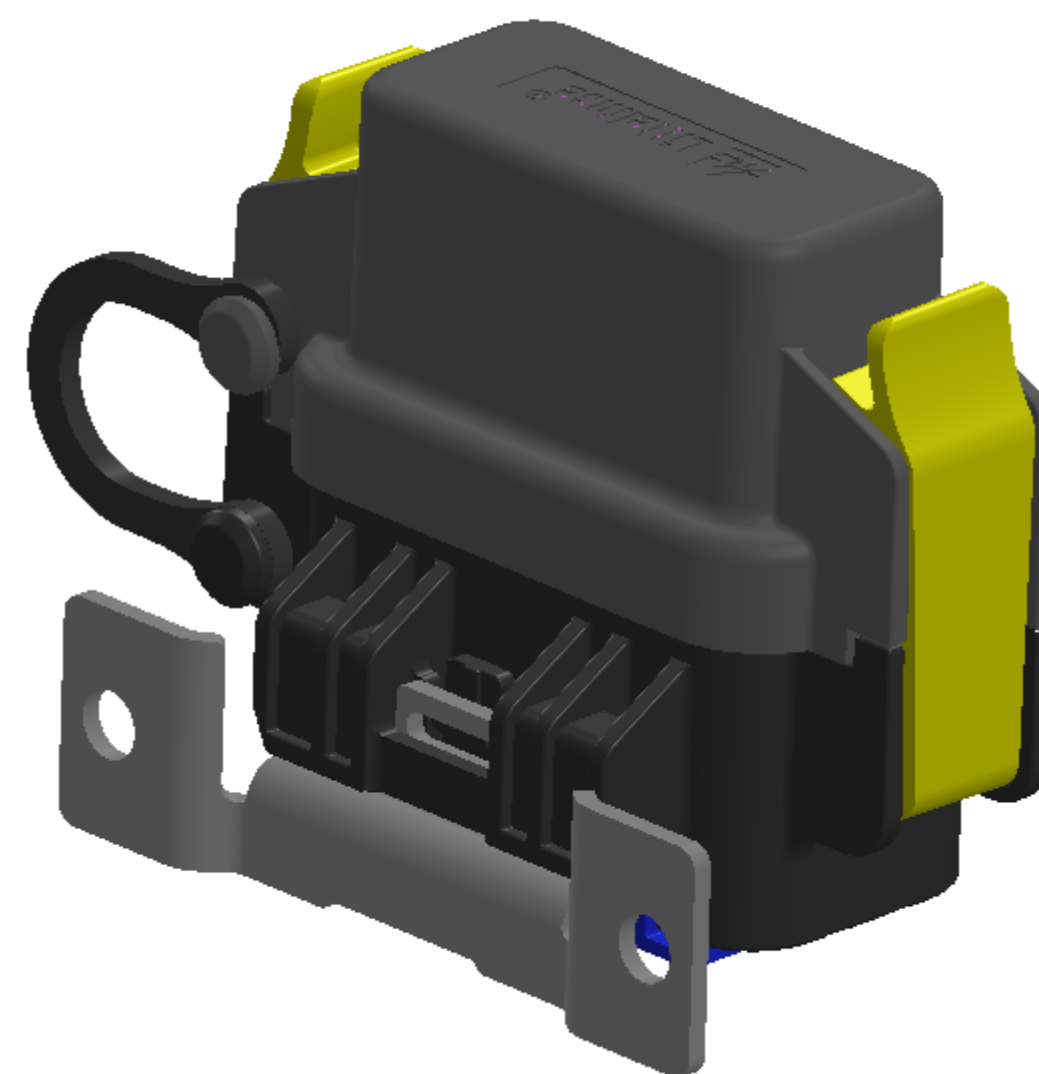
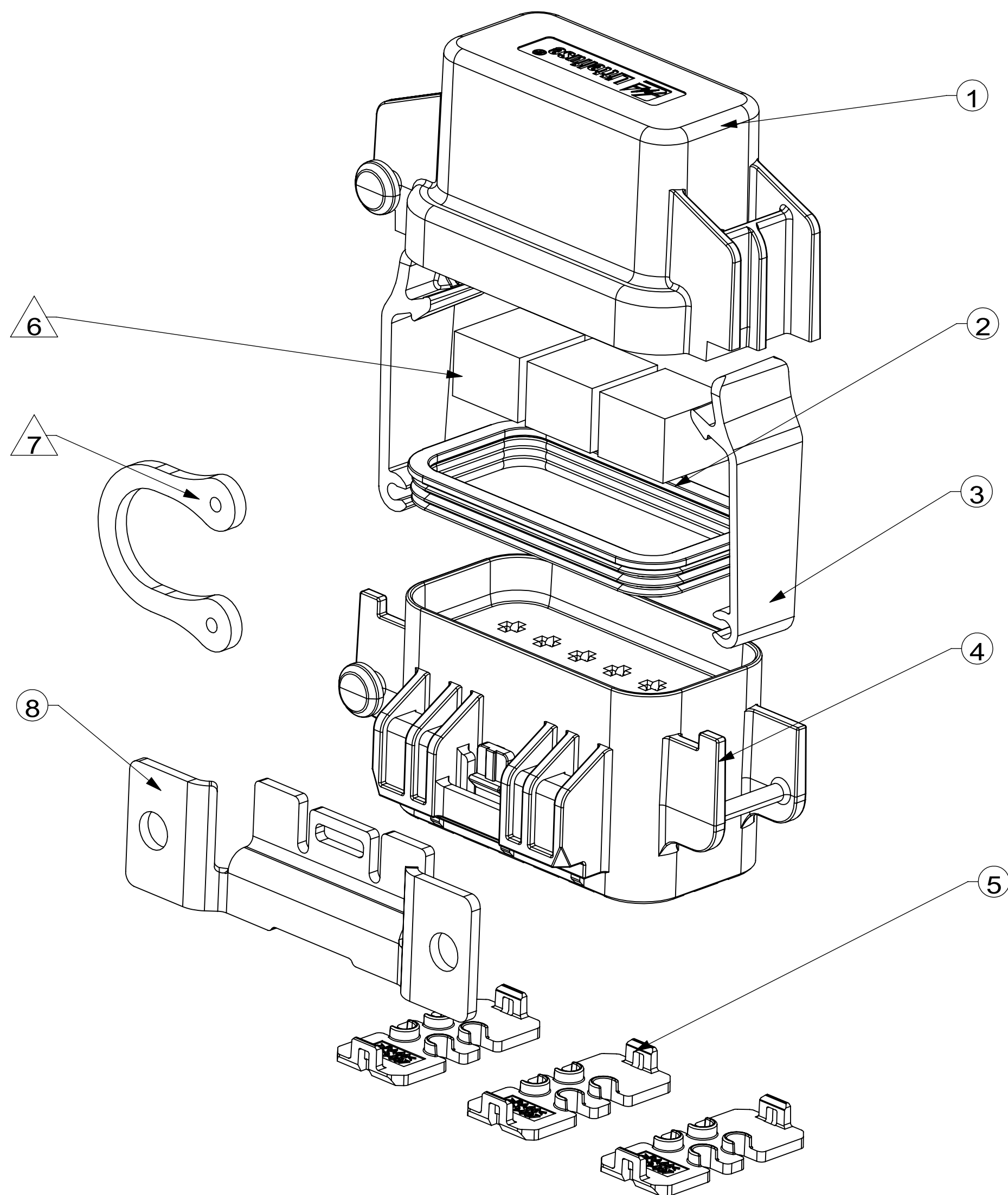

NOTE:
PARTS MARKED Δ TO BE ORDERED SEPARATELY.

#	PART	QTY	REMARK
1	COVER	1	TWO COLOR: CLEAR AND BALCK
2	SEAL	1	
3	YELLOW LATCH	2	
4	BASE	1	
5	TPA	3	
6	FOAM	0~3	APPLY 1 EA FOAM FOR EACH RELAY
7	TETHER	1	OPTIONAL, P/N: 890009470
8	BRACKET	1	OPTIONAL, P/N: 868-964

DIMENSIONS ARE SHOWN IN MILLIMETERS. DIMENSIONS AND TOLERANCES ARE DEFINED ACCORDING TO ANSIS/ASME Y14.5-1994.												
\bullet	DENOTES PRODUCTS CRITICAL CHARACTERISTICS											
CPK	DENOTES CPK DIMENSIONS MINIMUM CPK VALUE											
ST	DENOTES A CHARACTERISTIC THAT PROVIDES AN INDICATION OF PROCESS PERFORMANCE PROCEDURE FOR MEASUREMENT AND TRACKING TO BE DEFINED IN LITTELFUSE INSPECTION INSTRUCTIONS											
CP	DENOTES CP DIMENSIONS. -MINIMUM CP VALUE MUST BE WITHIN THE DIMENSIONAL LIMITATIONS SHOWN ON DRAWING AND INITIALLY LOCATED TO ALLOW FOR MAXIMUM TOOL LIFE											
TOLERANCES UNLESS OTHERWISE SPECIFIED (REF. ISO2768-M)												
DIMENSION	UP TO 0.5	OVER 0.5 - 3	UP TO 3	OVER 3 - 6	UP TO 6	OVER 6 - 30	UP TO 30	OVER 30 - 120	UP TO 120	OVER 120 - 400	UP TO 400	ANGLE
TOLERANCES	± 0.1		± 0.1		± 0.2		± 0.3		± 0.5		$\pm 1^\circ$	
DRAWN	NAME	DATE	 Excelsite Applied Answere's Best word No.6 Xinghai Street, Suzhou Industry Park, China Phone +86 512 6761 3189 Fax +86 512 6761 1489									
CHECKED												
THIRD ANGLE PROJECTION			TITLE									
DO NOT SCALE DRAWING			SCALE 1:2									
SIZE C			DWG. NO. OL-PDM33000ZXM									
SHEET 2 OF 3			REV. D									

REVISIONS				
ZONE	REV.	DESCRIPTION	DATE	APPROVED
		SEE PAGE 1		

ASSEMBLY STEPS (FOR CUSTOMER ASSEMBLY USE ONLY)

STEP1: OPEN THE YELLOW LATCHES BY HAND, AND REMOVE THE COVER.

STEP2: PUT CABLE THROUGH THE CABLE SEAL AND STRIP THE CABLE, CRIMP THE CABLE AND CABLE SEAL WITH TE 2.8mm TERMINAL.

STEP3: INSERT THE CABLE WITH TERMINAL TO THE CABLE CAVITIES OF BASE UNTIL HEAR A CLICK SOUND, AND THEN SNAP THE TPAS TO THE BASE.

STEP4: INSERT 6 MINI FUSES OR COMBINATION OF MINI FUSE, MCASE FUSE (NEED ADAPTER), MINI CIRCUIT BREAKER AND RELAY.
PASTE A FOAM (901-327) ON THE RELEVANT PLACE IN COVER FOR EACH RELAY (IF APPLIED).

STEP5: ASSEMBLE THE COVER (SEAL SEATED BY LATCHES) WITH BASE AND SNAP THE YELLOW LATCHES.

STEP6: OPTIONAL: INSERT THE BRACKET TO THE UNIT.

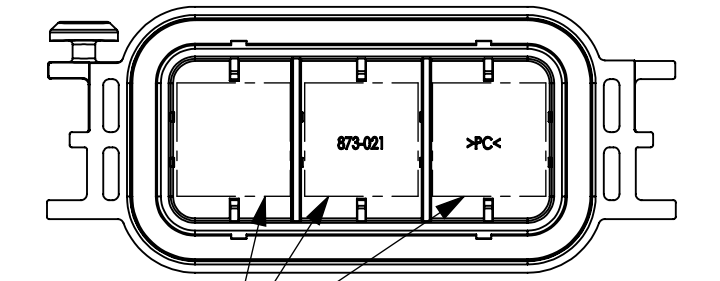
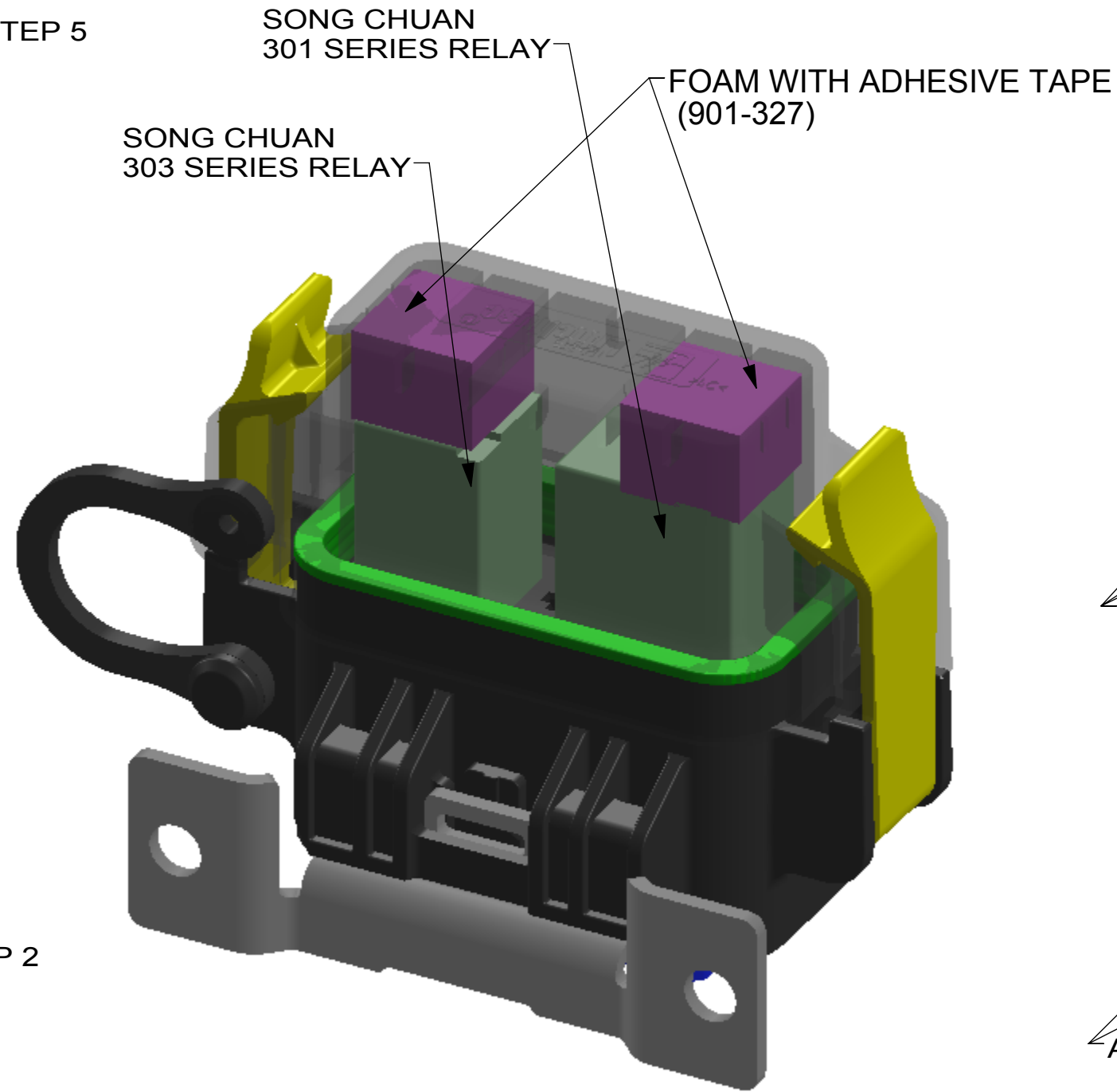
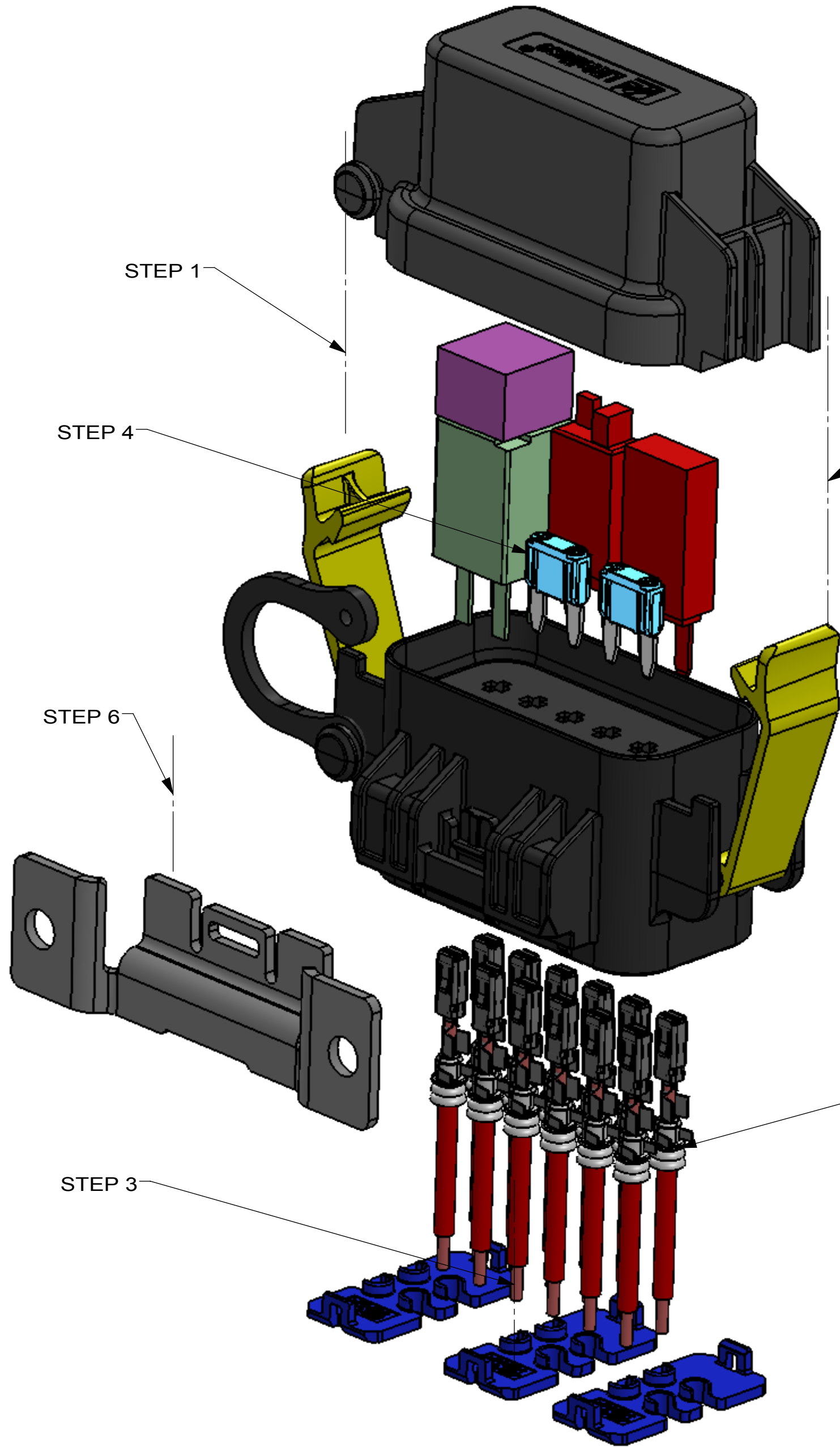

FOAM AREAS IN COVER

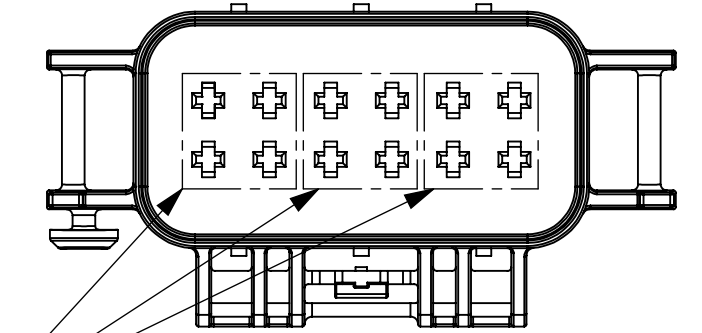

ALLOWED LOCATIONS FOR 4-PIN RELAY

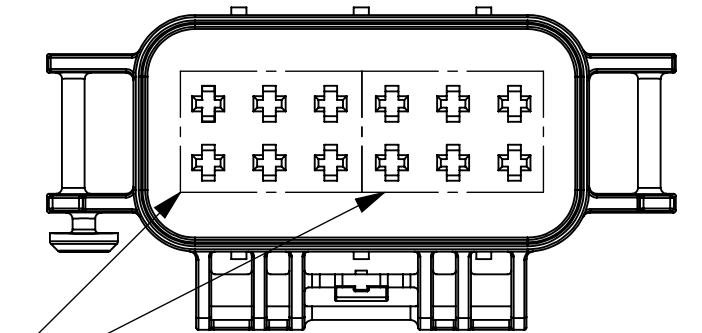

ALLOWED LOCATIONS FOR 5-PIN RELAY

VIEW WITH RELAYS AND FOAMS

DIMENSIONS ARE SHOWN IN MILLIMETERS. DIMENSIONS AND TOLERANCES ARE DEFINED ACCORDING TO ANSIA/SME Y14.5-1994.						
●	DENOTES PRODUCTS CRITICAL CHARACTERISTICS					
CPK	DENOTES CPK DIMENSIONS MINIMUM CPK VALUE					
ST	DENOTES A CHARACTERISTIC THAT PROVIDES AN INDICATION OF PROCESS PERFORMANCE PROCEDURE FOR MEASUREMENT AND TRACKING TO BE DEFINED IN LITTELFUSE INSPECTION INSTRUCTIONS					
CP	DENOTES CP DIMENSIONS. -MINIMUM CP VALUE MUST BE WITHIN THE DIMENSIONAL LIMITATIONS SHOWN ON DRAWING AND INITIALLY LOCATED TO ALLOW FOR MAXIMUM TOOL LIFE					
TOLERANCES UNLESS OTHERWISE SPECIFIED (REF. ISO2768-M)						
DIMENSION	UP TO 0.5 - 3	OVER 3 - 6	OVER 6 - 30	OVER 30 - 120	OVER 120 - 400	ANGLE
TOLERANCES	±0.1	±0.1	±0.2	±0.3	±0.5	±1°
NAME	DATE	Littelfuse				
DRAWN	J. LI	10/29/2015	No.6 Xinghai Street, Suzhou Industry Park, China			
CHECKED			Phone +86 512 6761 3189 Fax +86 512 6761 1489			
TITLE				HARD WIRE BOX -12		
THIRD ANGLE PROJECTION						
DO NOT SCALE DRAWING	SCALE 1:1	SIZE C	DWG. NO.	REV. D	SHEET 3 OF 3	
			OL-PDM33000ZXM			