

MOUNTING SPECS:

RECOMMENDED FASTENER: M10 OR 3/8"
TIGHTENING TORQUE (REFERENCE ONLY): 26Nm

REVISION		
REV	DATE	DESCRIPTION
A	3/11/20	522093GCP - RELEASE MRY
B	4/20/20	522239ECP/D - ADD TOLERANCES MRY
C	5/10/22	525179ECP/D - CHANGE HEIGHT DIMENSION MRY
D	1/10/24	526835ECP/D - ADDED VIEW WITHOUT MICRO-SWITCH JTM

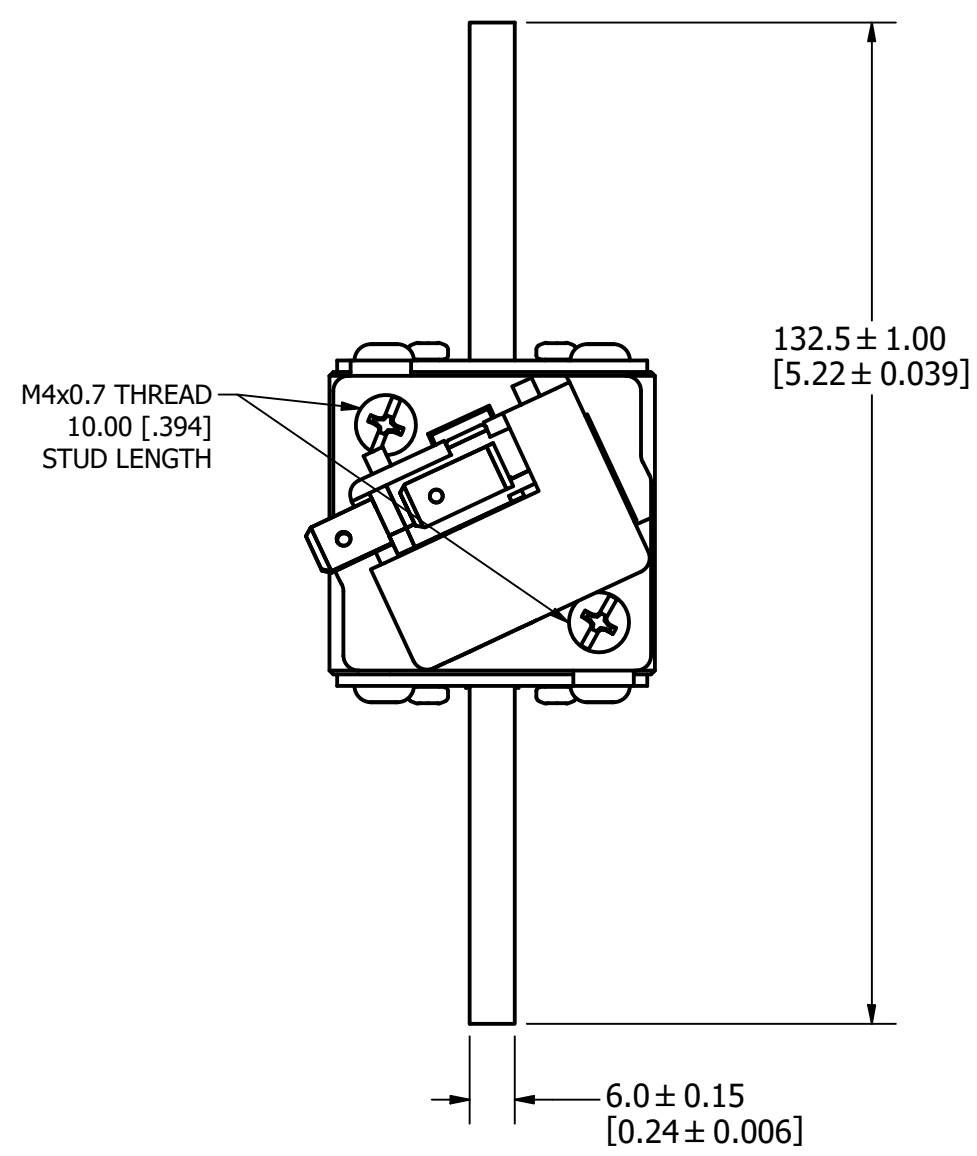

FUSE WITH MICRO-SWITCH

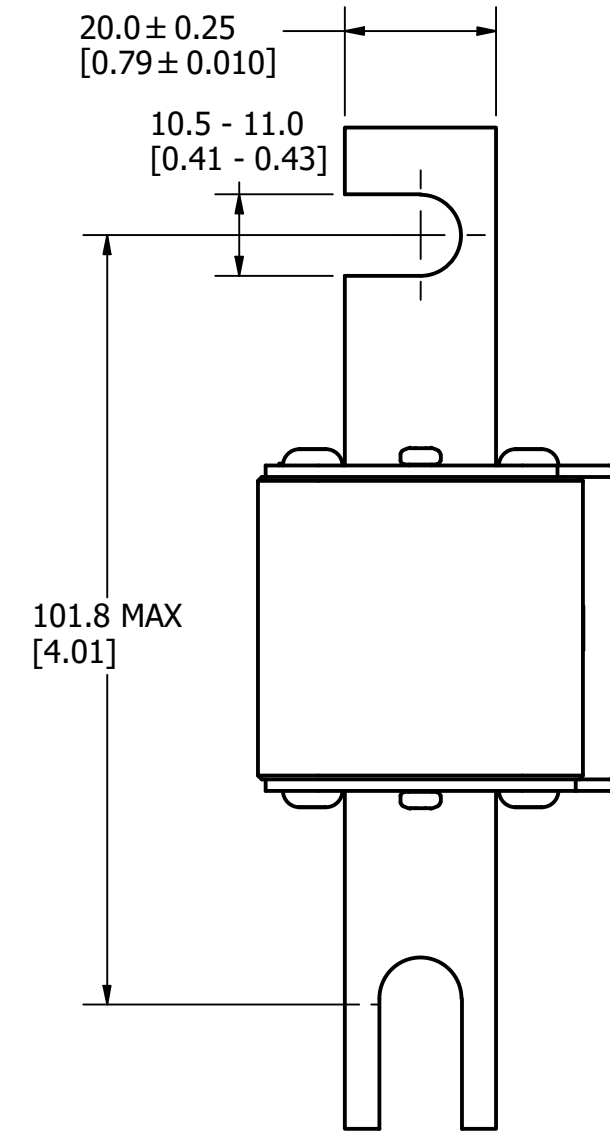
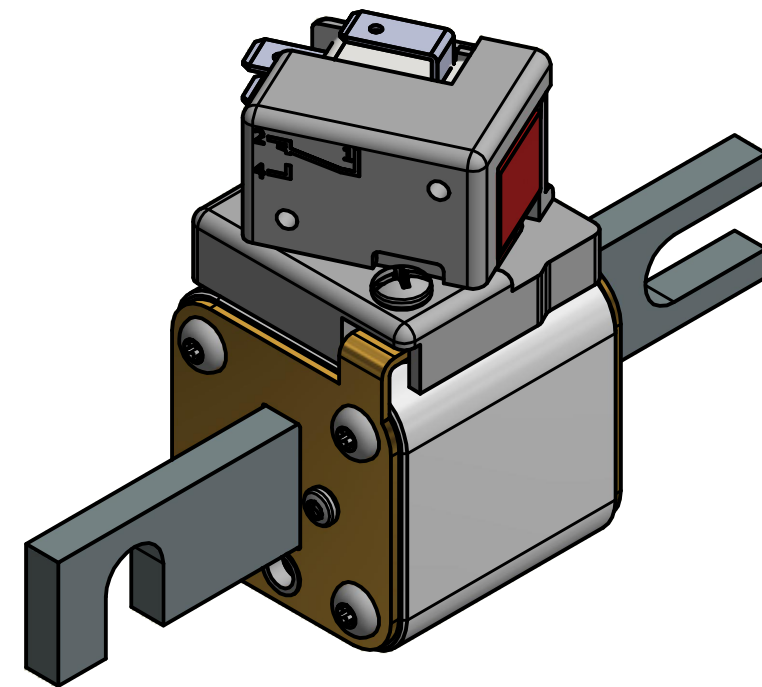

FUSE

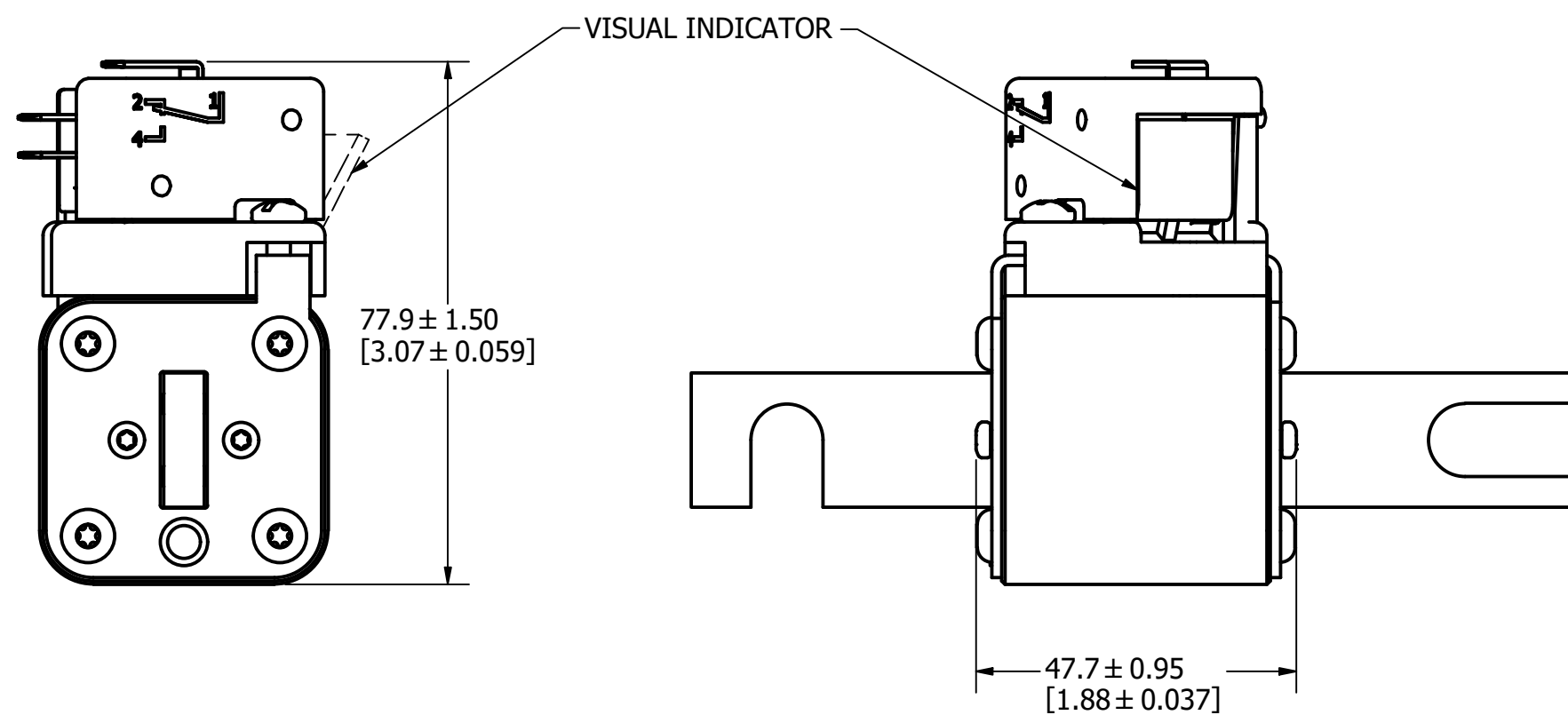
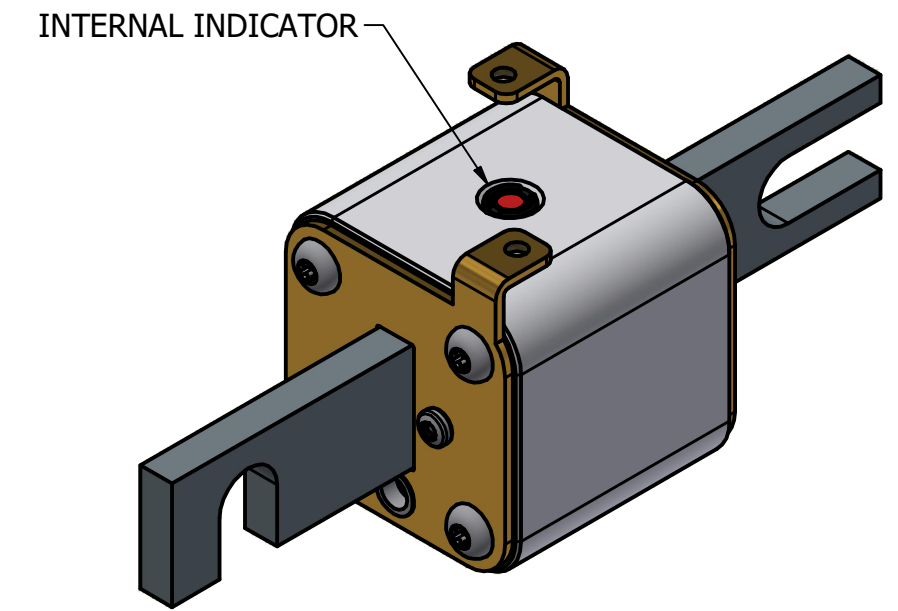

FUSE WITH MICRO-SWITCH

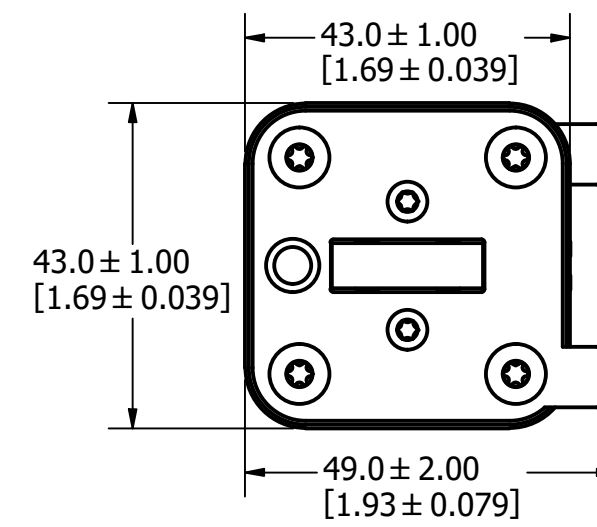

FOR REFERENCE ONLY

<S>	CRITICAL CHARACTERISTIC FOR PART SAFETY/COMPLIANCE
●	DENOTES CRITICAL CHARACTERISTICS.
CPK	DENOTES CPK DIMENSIONS, -MINIMUM CPK VALUE
(ST)	DENOTES A CHARACTERISTIC THAT PROVIDES AN INDICATION OF PROCESS PERFORMANCE. PROCEDURE FOR MEASUREMENT AND TRACKING TO BE DEFINED IN LITTELFUSE INSPECTION INSTRUCTIONS.
CP	DENOTES CP DIMENSIONS, -MINIMUM CP VALUE MUST BE WITHIN THE DIMENSIONAL LIMITATIONS SHOWN ON DRAWING AND INITIALLY LOCATED TO ALLOW FOR MAXIMUM TOOL LIFE.

MATL SPEC	FINISH
DRW myork	DATE 1/31/2024
SCALE NTS	FINISH GOOD WT GRAMS/PIECE

UNLESS OTHERWISE SPECIFIED, DIMENSIONS ARE IN MILLIMETERS, DIMENSIONS IN BRACKETS [] ARE INCHES DIMENSIONING AND DO NOT INCLUDE PLATING. TOLERANCING TO BE INTERPRETED IN ACCORDANCE WITH ANSI Y14.5M-1994

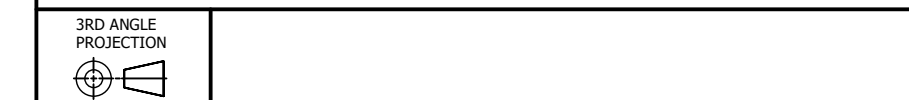

TITLE PSR SIZE 30 DIN 110 (DL) FUSE OUTLINE

Littelfuse CHICAGO, ILLINOIS 60631	REVISION D	DRWG NO. OL-PSR030DL000	SHEET 1 OF 1
--	------------	-------------------------	--------------

MOUNTING SPECS:

RECOMMENDED FASTENER: M10 OR 3/8"
TIGHTENING TORQUE (REFERENCE ONLY): 26Nm

REVISION		
REV	DATE	DESCRIPTION
A	3/11/20	522093GCP - RELEASE MRY
B	4/20/20	522239ECP/D - ADD TOLERANCES MRY
C	5/10/23	525179ECP/D - CHANGE HEIGHT DIMENSION MRY
D	1/11/24	526835ECP/D - ADDED VIEW WITHOUT MICRO-SWITCH JTM

FUSE WITH MICRO-SWITCH

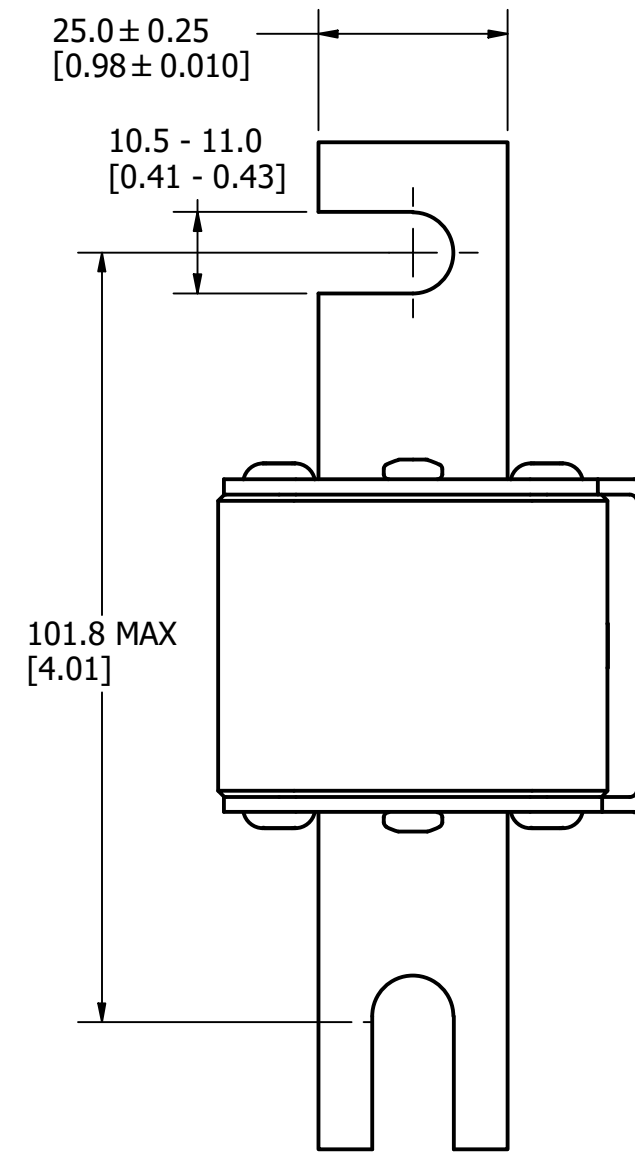
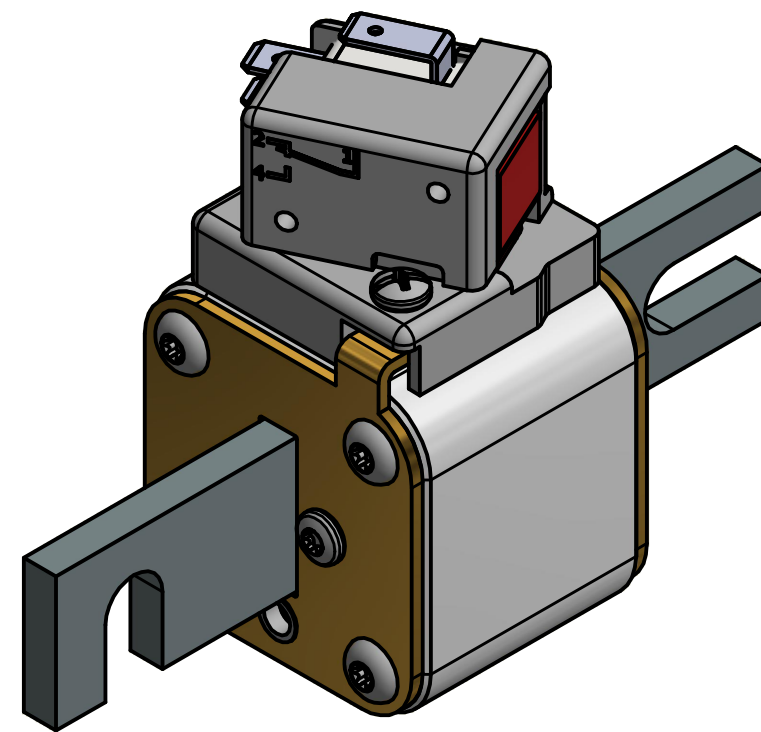
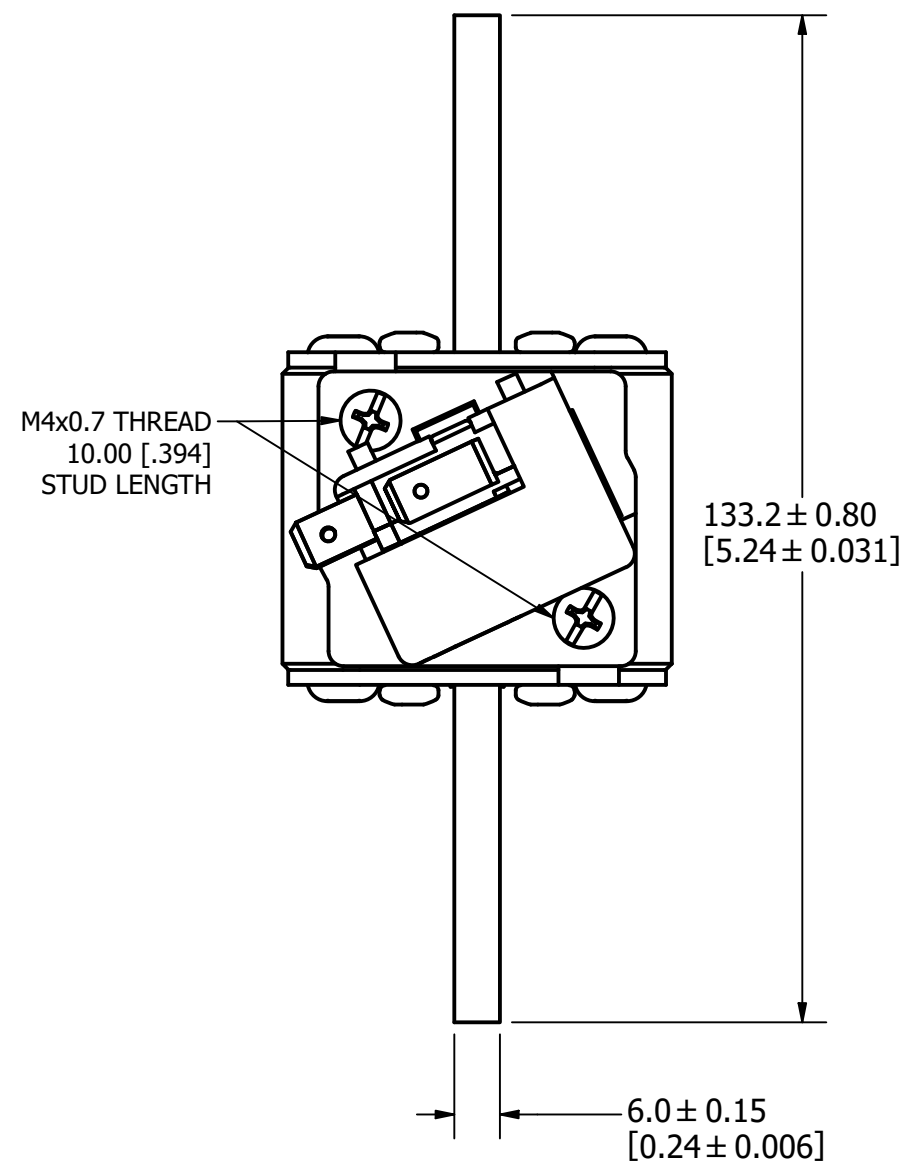

FUSE

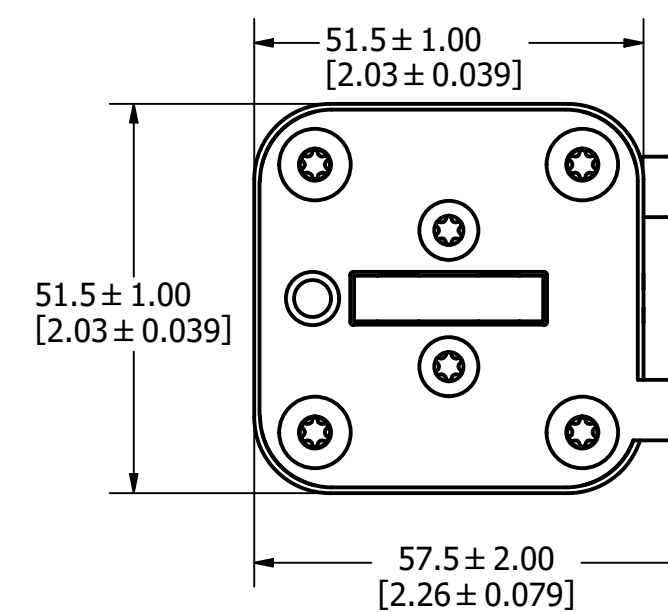
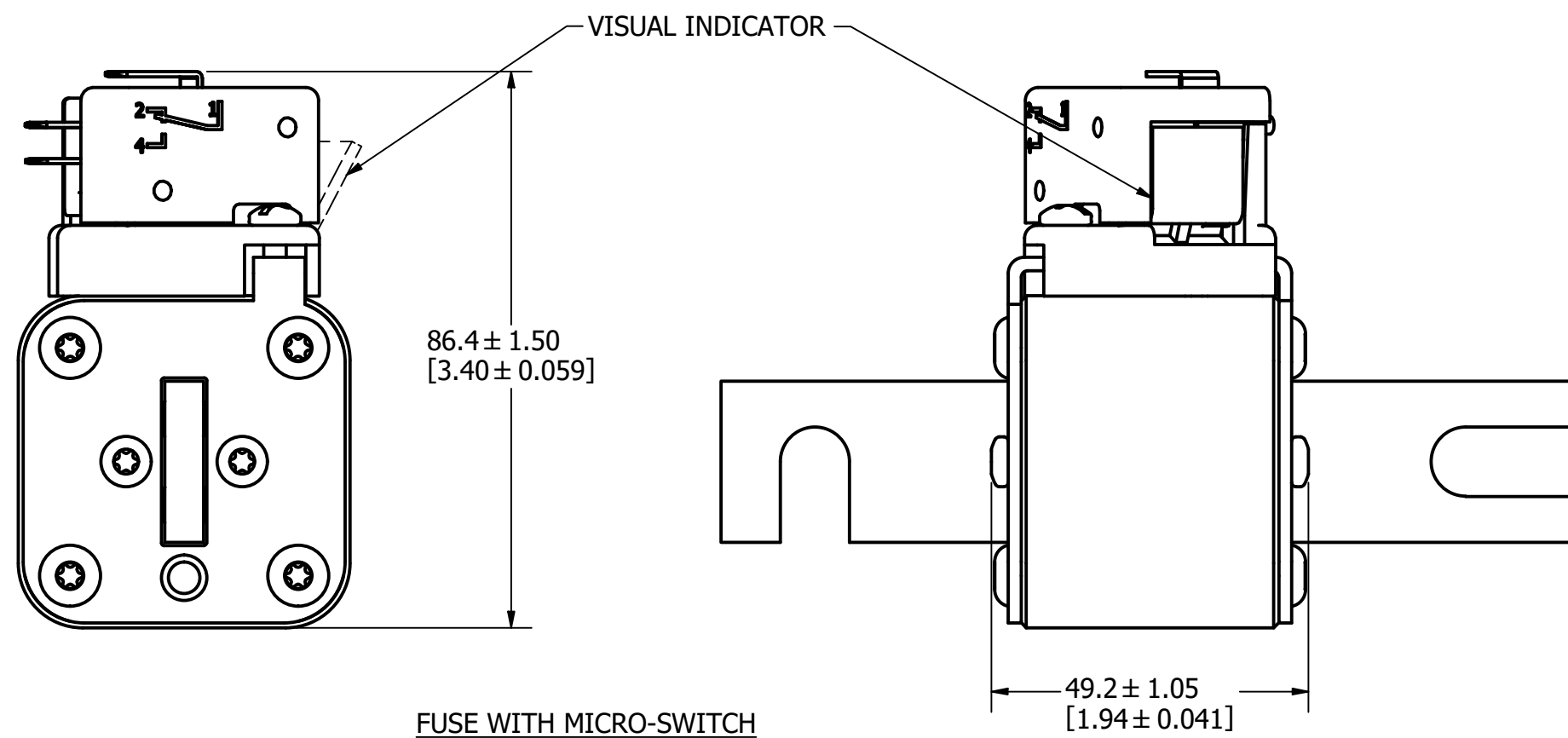
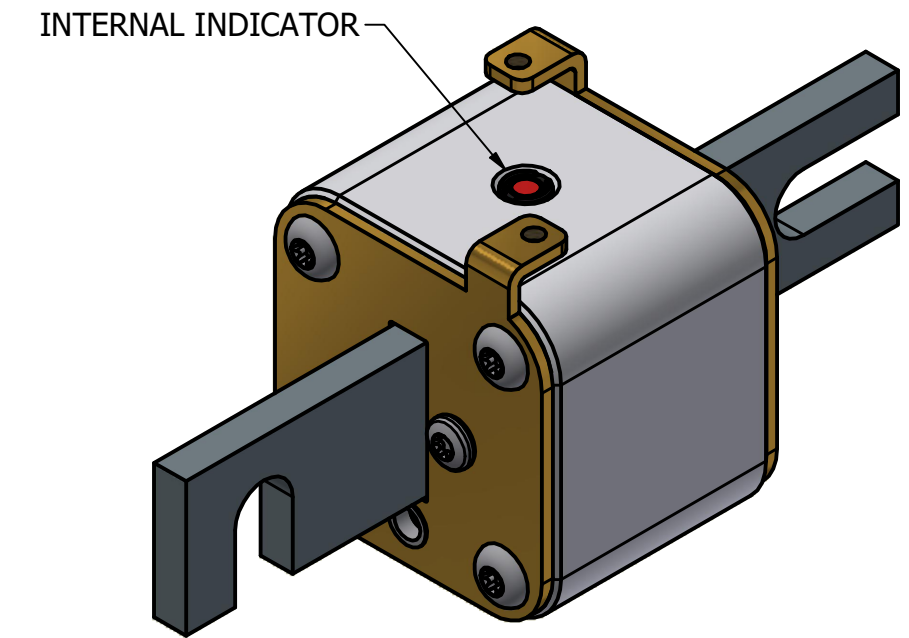

FOR REFERENCE ONLY

<S>	CRITICAL CHARACTERISTIC FOR PART SAFETY/COMPLIANCE		
●	DENOTES CRITICAL CHARACTERISTICS.		
CPK	DENOTES CPK DIMENSIONS, -MINIMUM CPK VALUE		
(ST)	DENOTES A CHARACTERISTIC THAT PROVIDES AN INDICATION OF PROCESS PERFORMANCE. PROCEDURE FOR MEASUREMENT AND TRACKING TO BE DEFINED IN LITTELFUSE INSPECTION INSTRUCTIONS.		
CP	DENOTES CP DIMENSIONS, -MINIMUM CP VALUE MUST BE WITHIN THE DIMENSIONAL LIMITATIONS SHOWN ON DRAWING AND INITIALLY LOCATED TO ALLOW FOR MAXIMUM TOOL LIFE.		
MATL SPEC		FINISH	
DRW myork	DATE 2/1/2024	SCALE NTS	FINISH GOOD WT GRAMS/PIECE
UNLESS OTHERWISE SPECIFIED, DIMENSIONS ARE IN MILLIMETERS, DIMENSIONS IN BRACKETS [] ARE INCHES DIMENSIONING AND DO NOT INCLUDE PLATING. TOLERANCING TO BE INTERPRETED IN ACCORDANCE WITH ANSI Y14.5M-1994			
3RD ANGLE PROJECTION			
TITLE PSR SIZE 31 DIN 110 (DL) FUSE OUTLINE			
Littelfuse® CHICAGO, ILLINOIS 60631		REVISION D	DRWG NO. OL-PSR031DL0000 SHEET 1 OF 1

MOUNTING SPECS:

RECOMMENDED FASTENER: M10 OR 3/8"
TIGHTENING TORQUE (REFERENCE ONLY): 26Nm

REVISION		
REV	DATE	DESCRIPTION
A	3/11/20	522093GCP - RELEASE MRY
B	4/20/20	522239ECP/D - ADD TOLERANCES MRY
C	5/10/22	525179ECP/D - CHANGE HEIGHT DIMENSION MRY
D	1/12/24	526835ECP/D - ADDED VIEW WITHOUT MICRO-SWITCH JTM

FUSE WITH MICRO-SWITCH

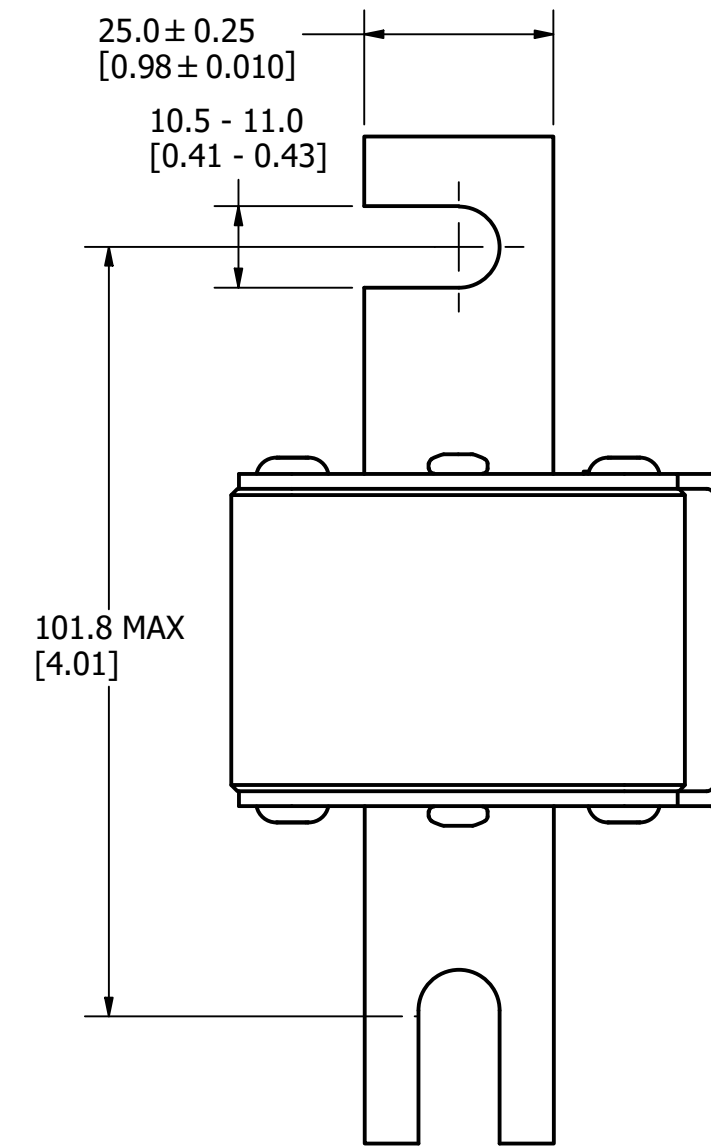
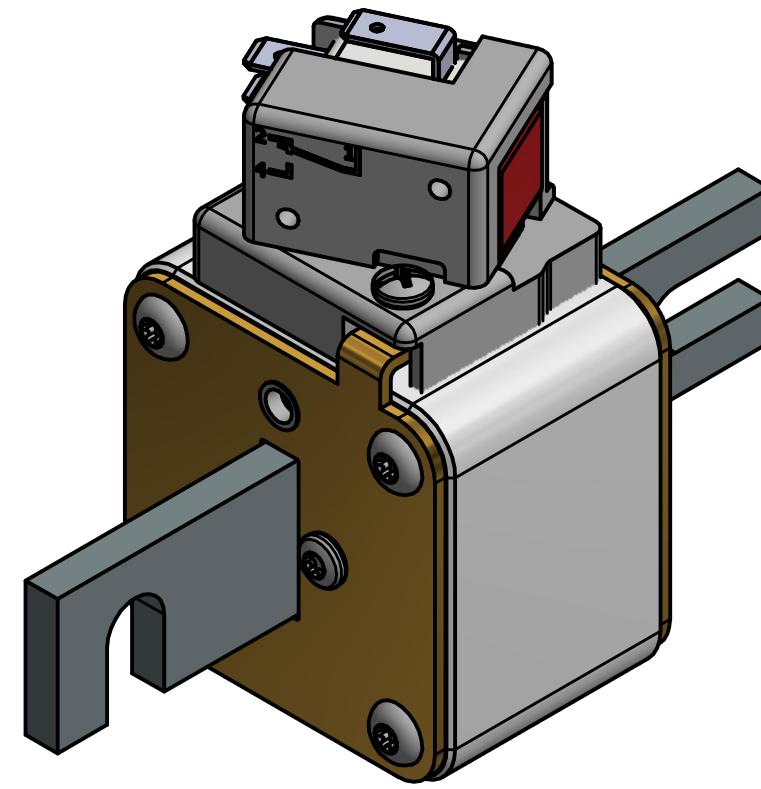
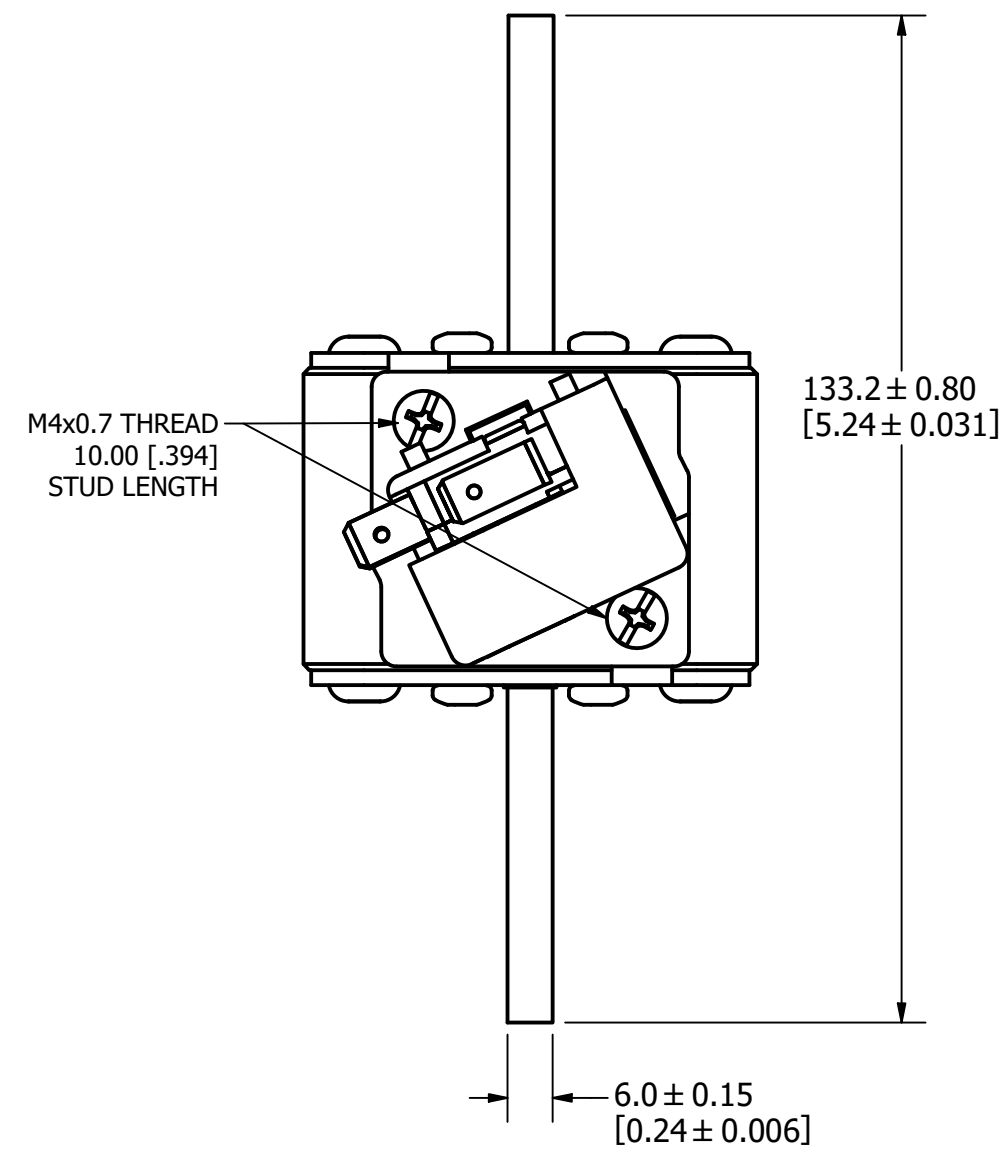

FUSE

INTERNAL INDICATOR

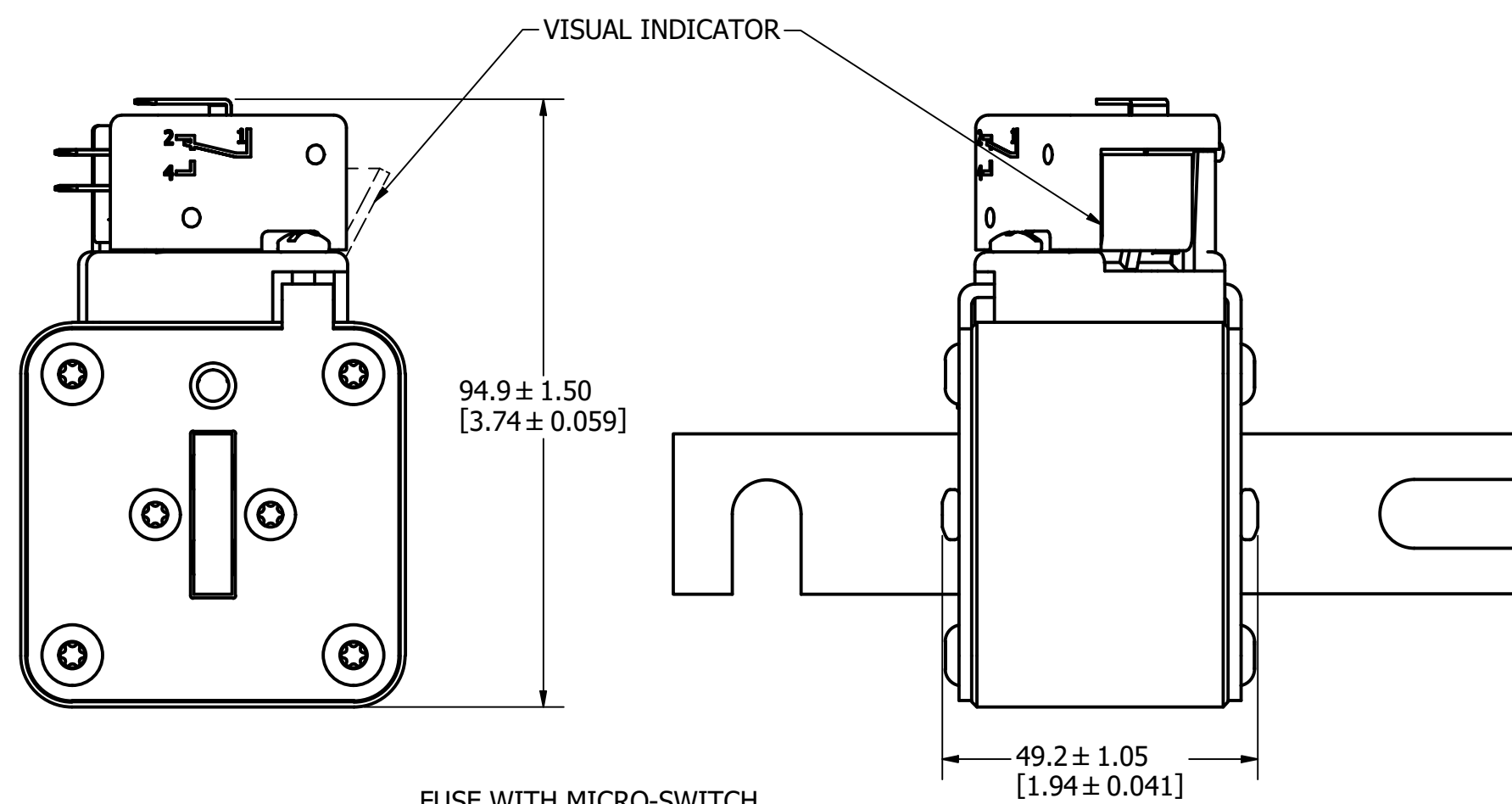
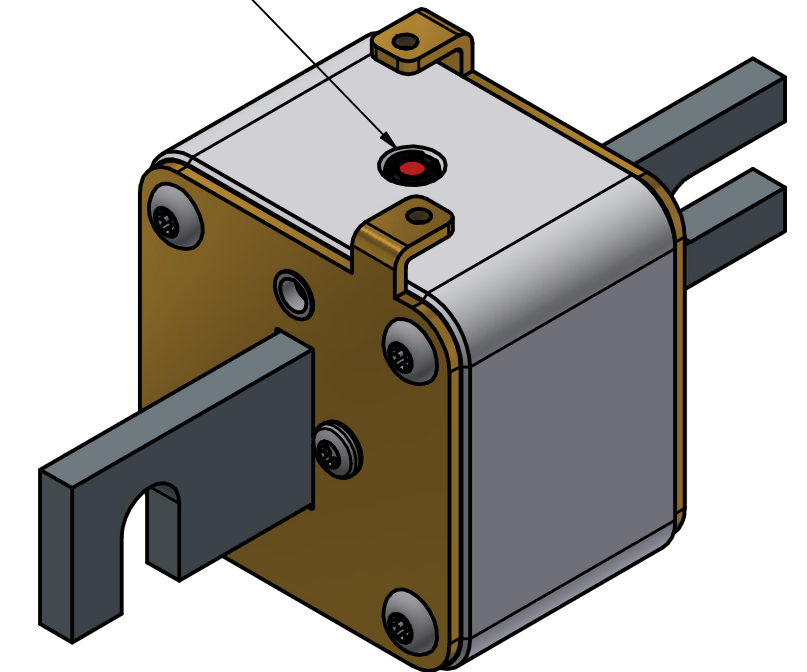

FUSE WITH MICRO-SWITCH

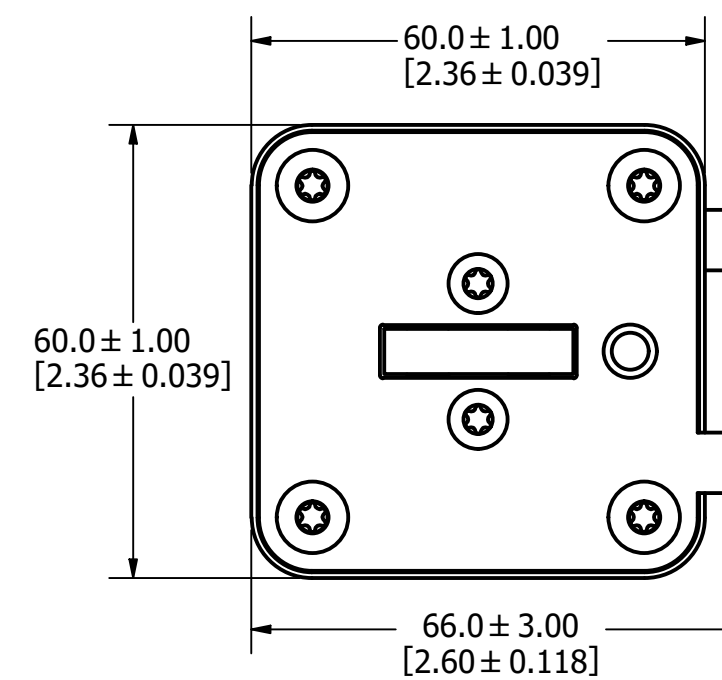

FOR REFERENCE ONLY

<S>	CRITICAL CHARACTERISTIC FOR PART SAFETY/COMPLIANCE
●	DENOTES CRITICAL CHARACTERISTICS.
CPK	DENOTES CPK DIMENSIONS, -MINIMUM CPK VALUE
(ST)	DENOTES A CHARACTERISTIC THAT PROVIDES AN INDICATION OF PROCESS PERFORMANCE. PROCEDURE FOR MEASUREMENT AND TRACKING TO BE DEFINED IN LITTELFUSE INSPECTION INSTRUCTIONS.
CP	DENOTES CP DIMENSIONS, -MINIMUM CP VALUE MUST BE WITHIN THE DIMENSIONAL LIMITATIONS SHOWN ON DRAWING AND INITIALLY LOCATED TO ALLOW FOR MAXIMUM TOOL LIFE.

MATL SPEC		FINISH	
DRW myork	DATE 12/31/1969	SCALE NTS	FINISH GOOD WT GRAMS/PIECE

UNLESS OTHERWISE SPECIFIED, DIMENSIONS ARE IN MILLIMETERS, DIMENSIONS IN BRACKETS [] ARE INCHES DIMENSIONING AND DO NOT INCLUDE PLATING. TOLERANCING TO BE INTERPRETED IN ACCORDANCE WITH ANSI Y14.5M-1994

3RD ANGLE PROJECTION	
----------------------	--

TITLE PSR SIZE 32 DIN 110 (DL) FUSE OUTLINE

Littelfuse CHICAGO, ILLINOIS 60631	REVISION D	DRWG NO. OL-PSR032DL0000	SHEET 1 OF 1
--	------------	--------------------------	--------------

MOUNTING SPECS:

RECOMMENDED FASTENER: M10 OR 3/8"
TIGHTENING TORQUE (REFERENCE ONLY): 26Nm

REVISION		
REV	DATE	DESCRIPTION
A	3/11/20	522093GCP - RELEASE MRY
B	4/20/20	522239ECP/D - ADD TOLERANCES MRY
C	5/10/22	525179ECP/D - CHANGE HEIGHT DIMENSION MRY
D	1/17/24	526835ECP/D - ADDED VIEW WITHOUT MICRO-SWITCH JTM

FUSE WITH MICRO-SWITCH

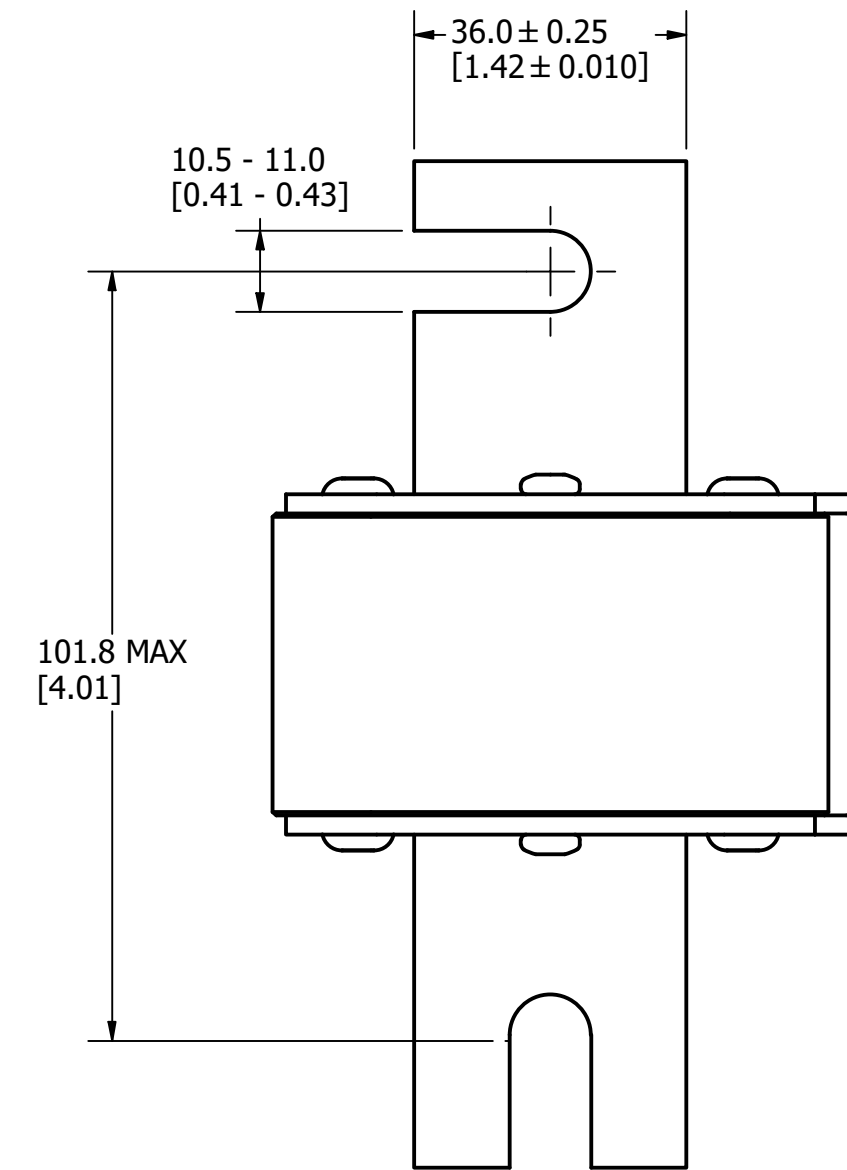
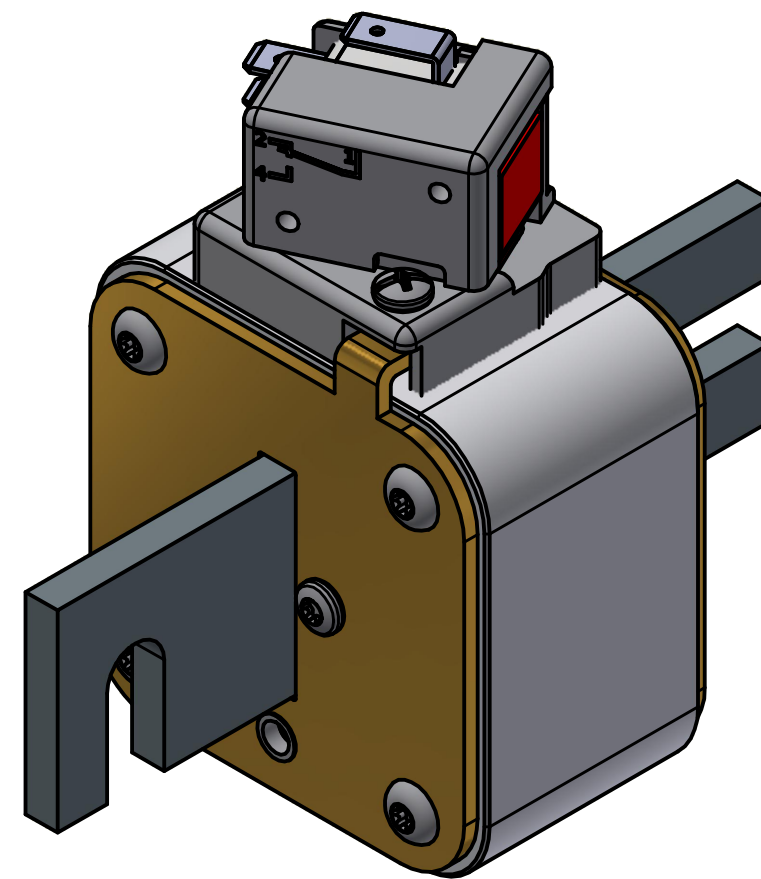
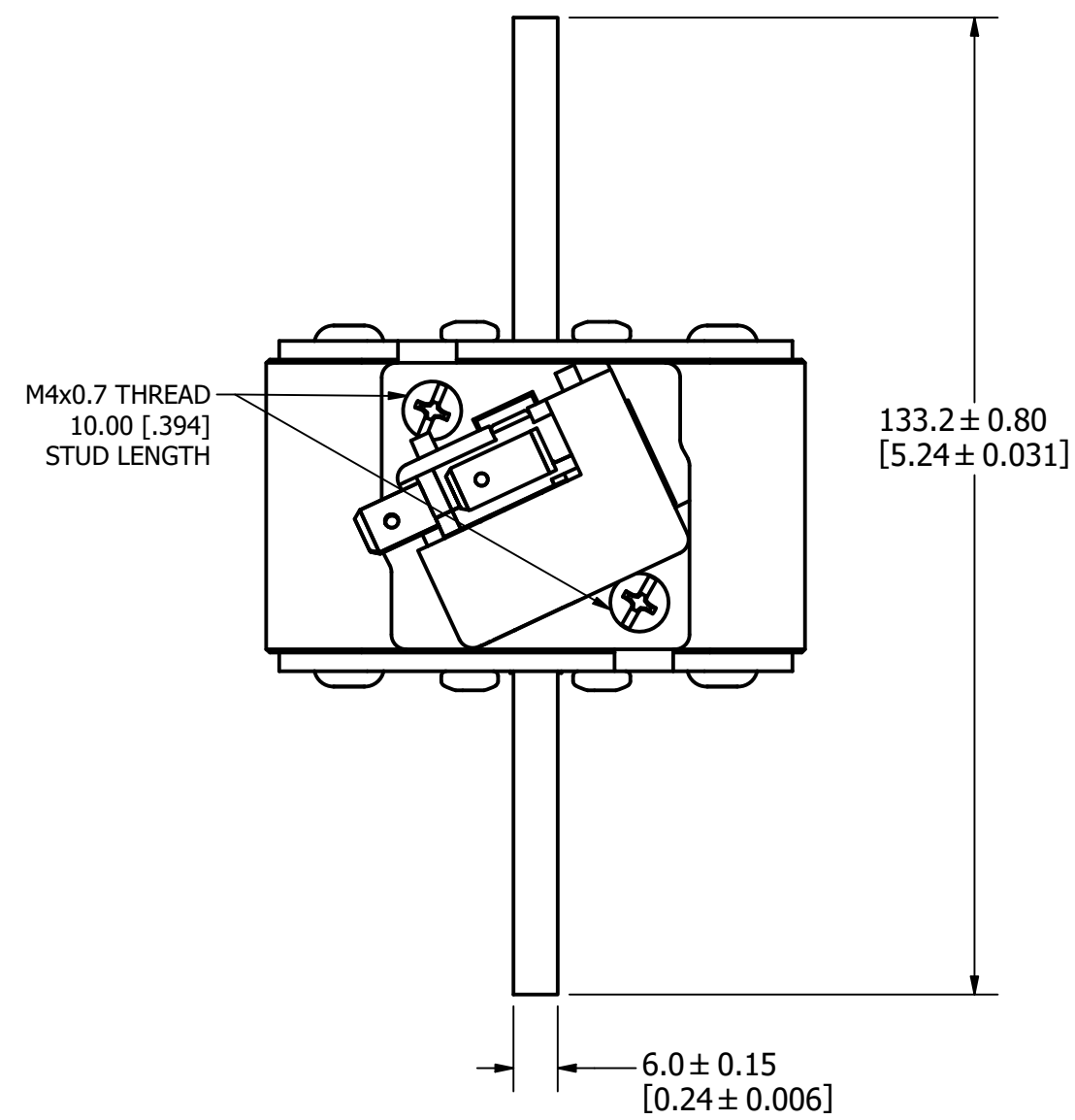

FUSE

INTERNAL INDICATOR

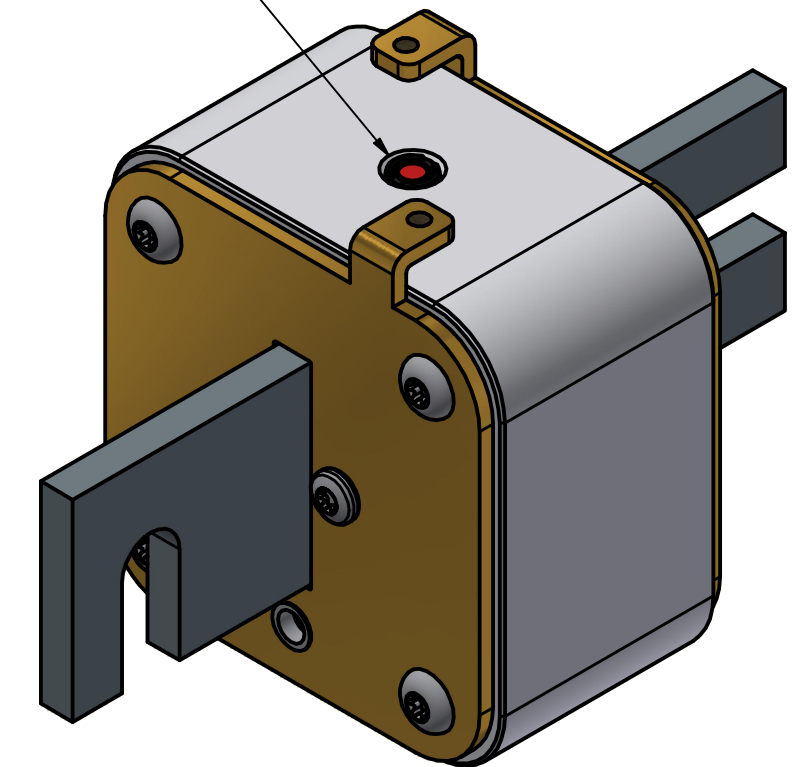

VISUAL INDICATOR

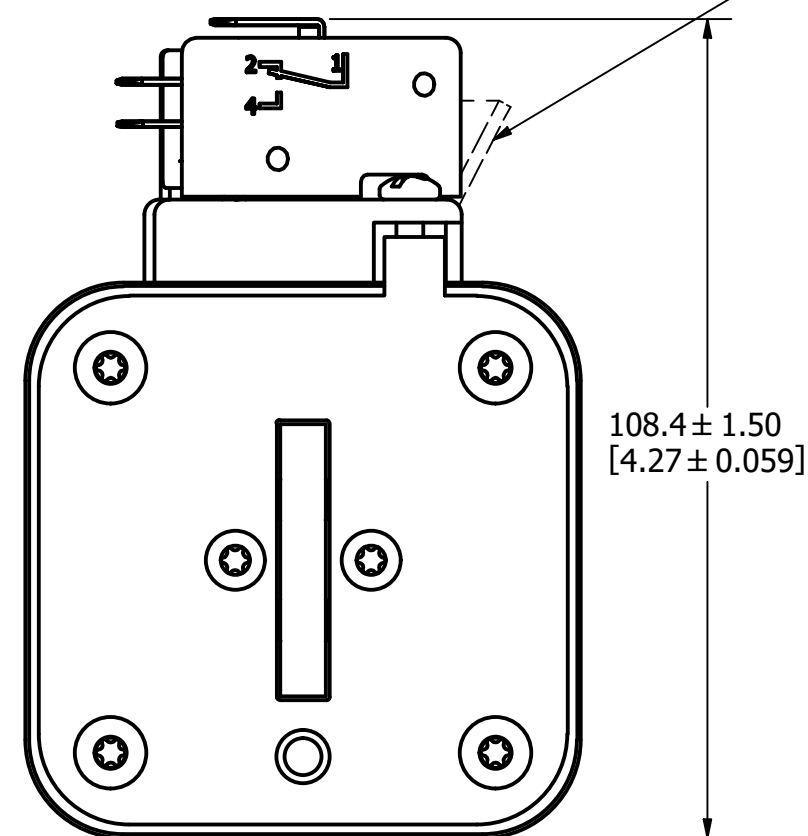

FUSE WITH MICRO-SWITCH

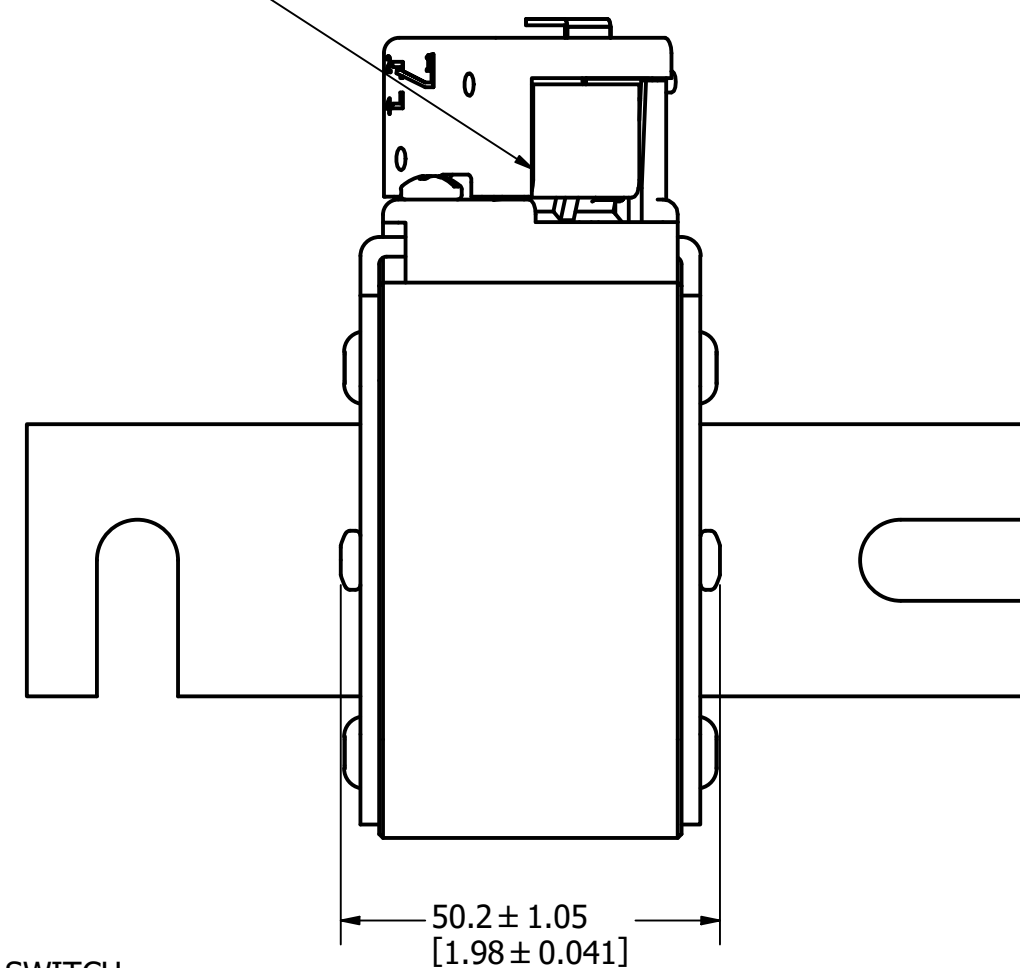

73.5 ± 1.00
[2.89 ± 0.039]

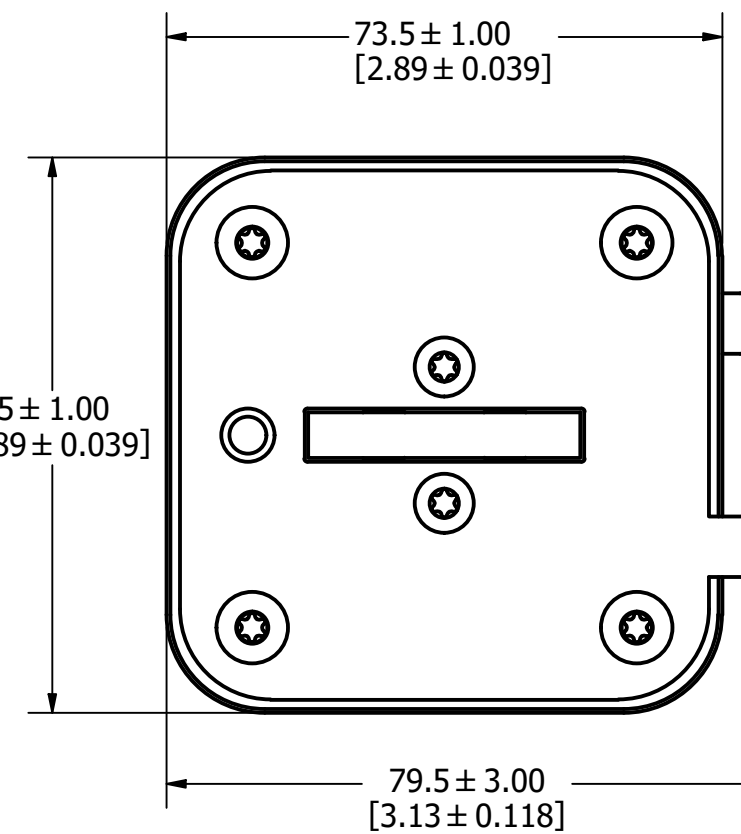

FOR REFERENCE ONLY

<S>	CRITICAL CHARACTERISTIC FOR PART SAFETY/COMPLIANCE
●	DENOTES CRITICAL CHARACTERISTICS.
CPK	DENOTES CPK DIMENSIONS, -MINIMUM CPK VALUE
(ST)	DENOTES A CHARACTERISTIC THAT PROVIDES AN INDICATION OF PROCESS PERFORMANCE. PROCEDURE FOR MEASUREMENT AND TRACKING TO BE DEFINED IN LITTELFUSE INSPECTION INSTRUCTIONS.
CP	DENOTES CP DIMENSIONS, -MINIMUM CP VALUE MUST BE WITHIN THE DIMENSIONAL LIMITATIONS SHOWN ON DRAWING AND INITIALLY LOCATED TO ALLOW FOR MAXIMUM TOOL LIFE.

MATL SPEC	FINISH
DRW myork	DATE 1/17/2024
SCALE NTS	FINISH GOOD WT GRAMS/PIECE

UNLESS OTHERWISE SPECIFIED, DIMENSIONS ARE IN MILLIMETERS, DIMENSIONS IN BRACKETS [] ARE INCHES DIMENSIONING AND DO NOT INCLUDE PLATING. TOLERANCING TO BE INTERPRETED IN ACCORDANCE WITH ANSI Y14.5M-1994

3RD ANGLE PROJECTION	
----------------------	--

TITLE PSR SIZE 33 DIN 110 (DL) FUSE OUTLINE

Littelfuse CHICAGO, ILLINOIS 60631	REVISION D	DRWG NO. OL-PSR033DL000	SHEET 1 OF 1
--	------------	-------------------------	--------------

MOUNTING SPECS:

RECOMMENDED FASTENER: M10 OR 3/8"
TIGHTENING TORQUE (REFERENCE ONLY): 26Nm

REVISION		
REV	DATE	DESCRIPTION
A	3/11/20	522093GCP - RELEASE MRY
B	4/20/20	522239ECP/D - ADD TOLERANCES MRY
C	5/11/22	5251180ECP/D - CHANGE HEIGHT DIMENSION MRY
D	10/24/23	526836ECP/D - ADD VIEW W/O MICROSWITCH MRY

FUSE WITH MICROSWITCH

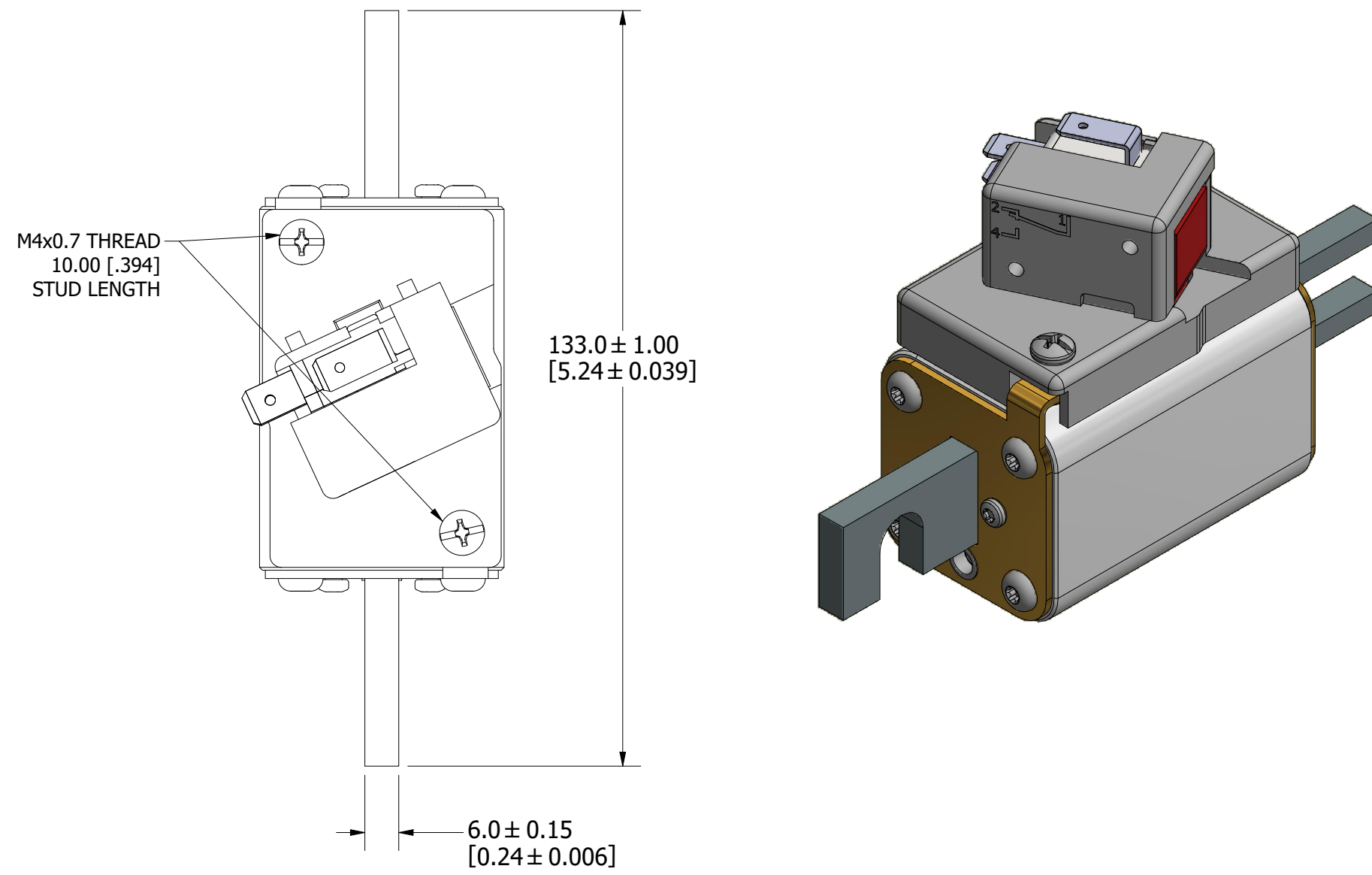

FUSE

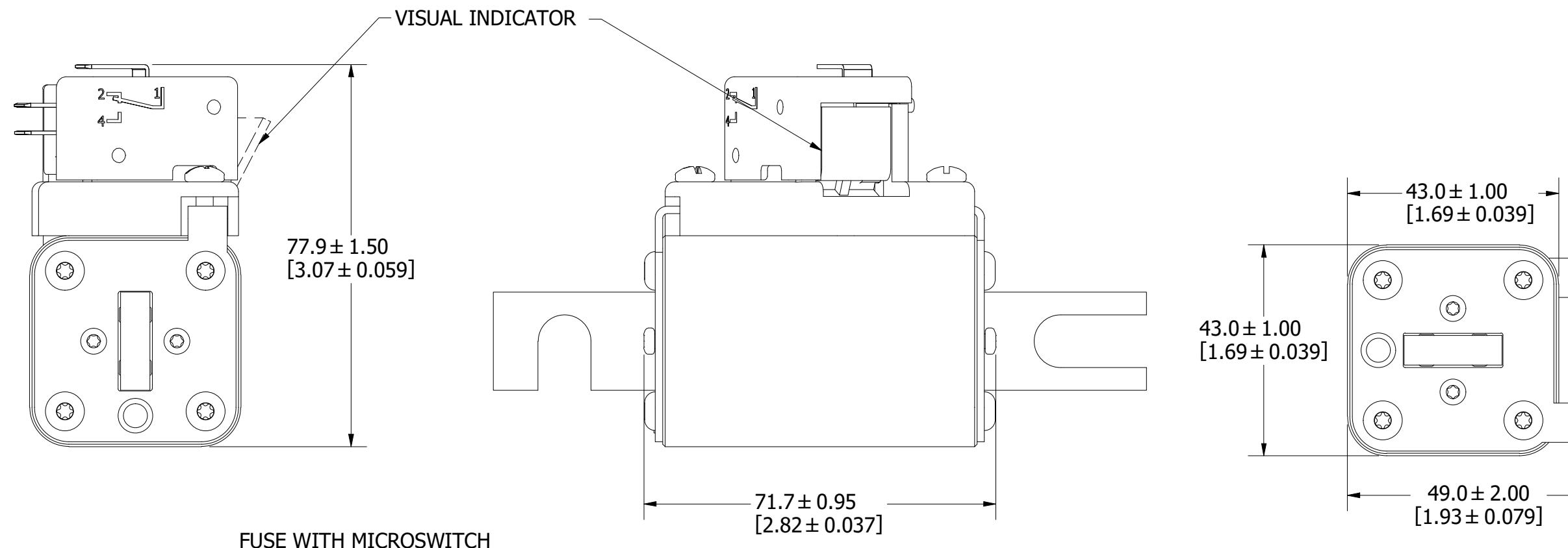
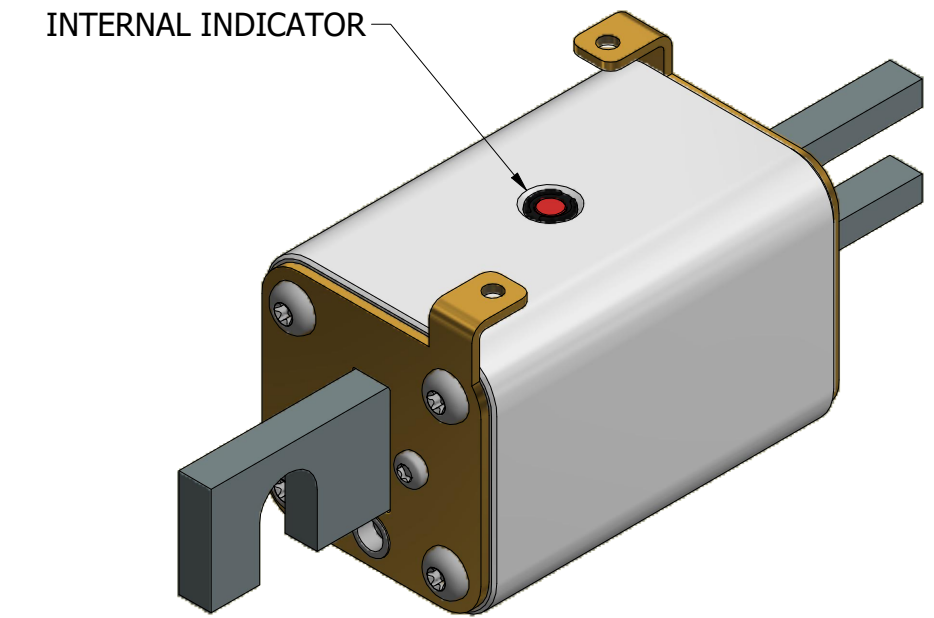
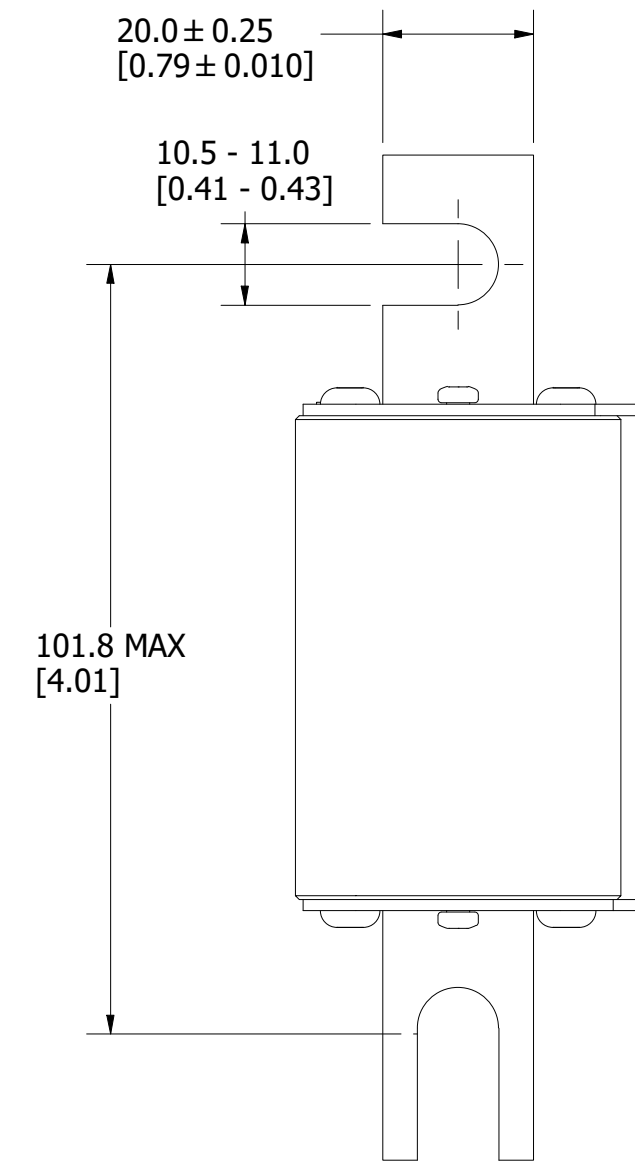

FUSE WITH MICROSWITCH

FOR REFERENCE ONLY

<S>	CRITICAL CHARACTERISTIC FOR PART SAFETY/COMPLIANCE
●	DENOTES CRITICAL CHARACTERISTICS.
CPK	DENOTES CPK DIMENSIONS, -MINIMUM CPK VALUE
Ⓢ	DENOTES A CHARACTERISTIC THAT PROVIDES AN INDICATION OF PROCESS PERFORMANCE. PROCEDURE FOR MEASUREMENT AND TRACKING TO BE DEFINED IN LITTELFUSE INSPECTION INSTRUCTIONS.
CP	DENOTES CP DIMENSIONS, -MINIMUM CP VALUE MUST BE WITHIN THE DIMENSIONAL LIMITATIONS SHOWN ON DRAWING AND INITIALLY LOCATED TO ALLOW FOR MAXIMUM TOOL LIFE.

MATL SPEC	FINISH
DRW myork	DATE 3/5/2020
SCALE NTS	FINISH GOOD WT GRAMS/PIECE

UNLESS OTHERWISE SPECIFIED, DIMENSIONS ARE IN MILLIMETERS, DIMENSIONS IN BRACKETS [] ARE INCHES DIMENSIONING AND DO NOT INCLUDE PLATING. TOLERANCING TO BE INTERPRETED IN ACCORDANCE WITH ANSI Y14.5M-1994

3RD ANGLE PROJECTION	
----------------------	--

TITLE PSR SIZE 70 DIN 110 (DL) FUSE OUTLINE

MOUNTING SPECS:

RECOMMENDED FASTENER: M10 OR 3/8"
TIGHTENING TORQUE (REFERENCE ONLY): 26Nm

REVISION		
REV	DATE	DESCRIPTION
A	3/11/20	522093GCP - RELEASE MRY
B	4/20/20	522239ECP/D - ADD TOLERANCES MRY
C	5/11/22	525180ECP/D - CHANGE HEIGHT DIMENSION MRY
D	10/24/23	526836ECP/D - ADD VIEW W/O MICROSWITCH MRY

FUSE WITH MICROSWITCH

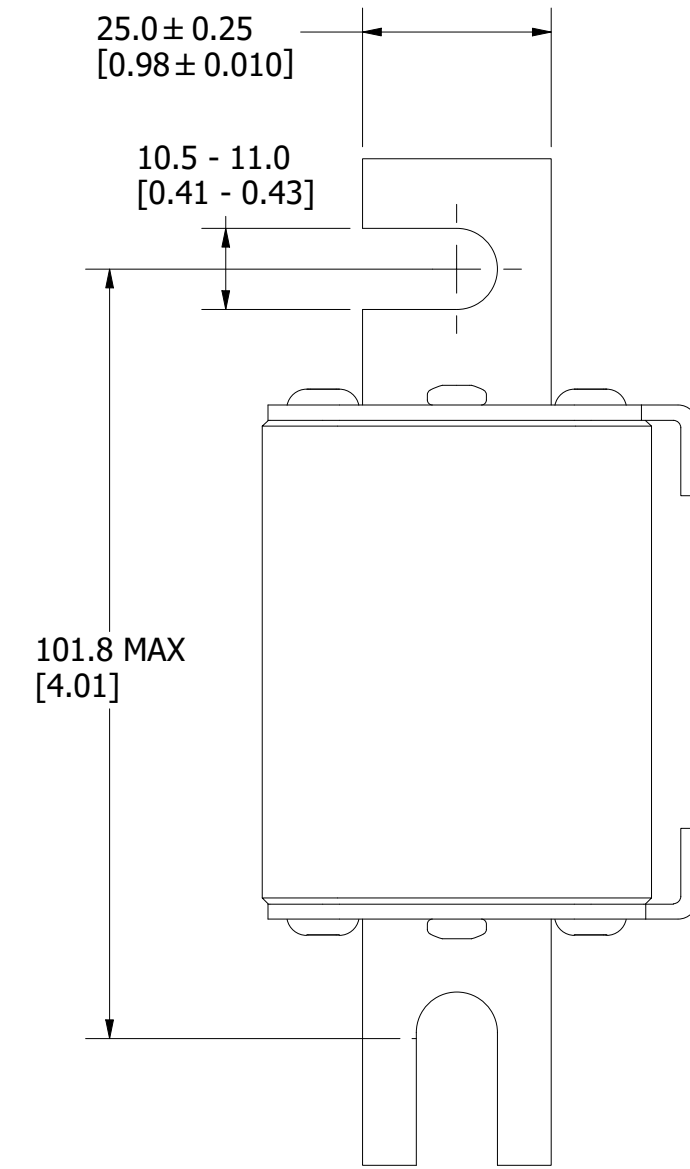
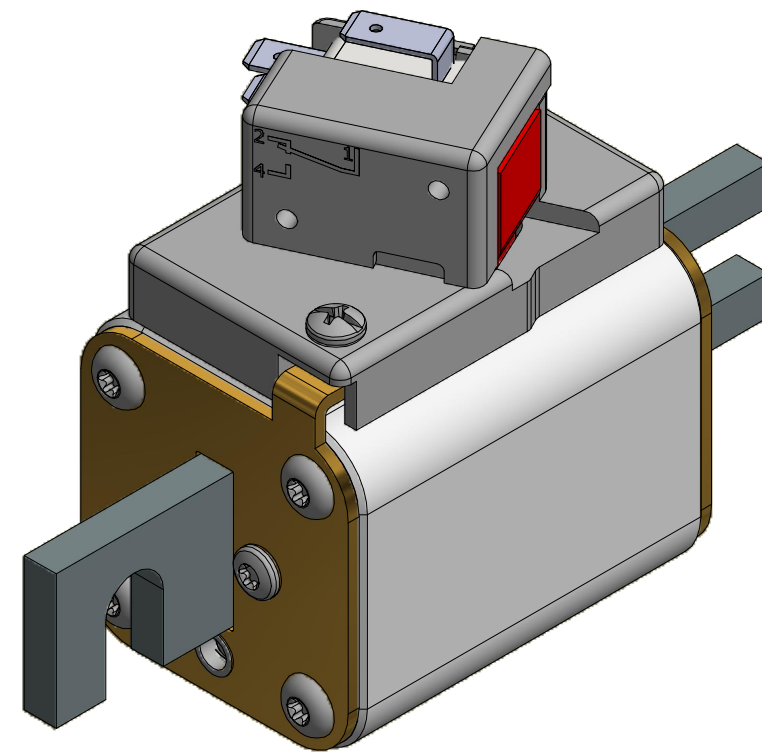
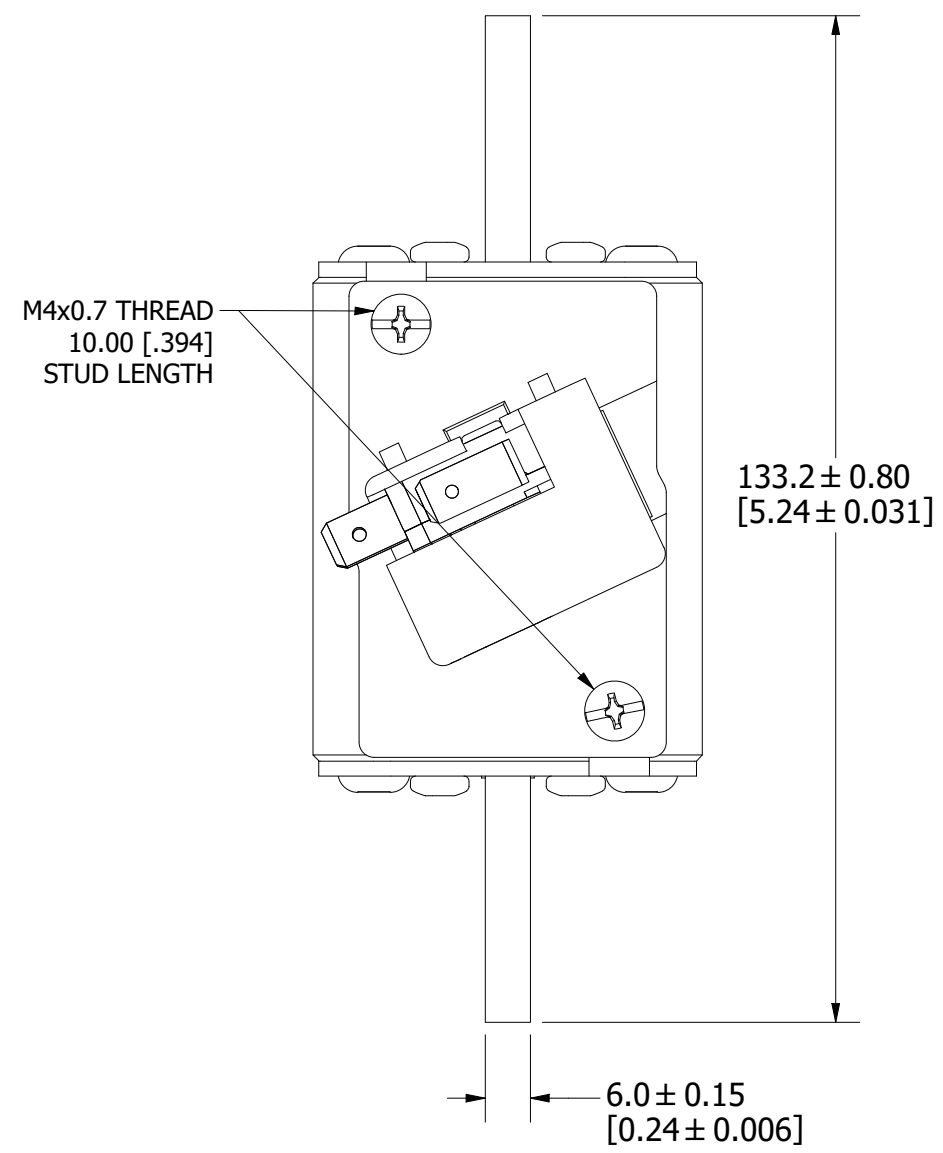

FUSE

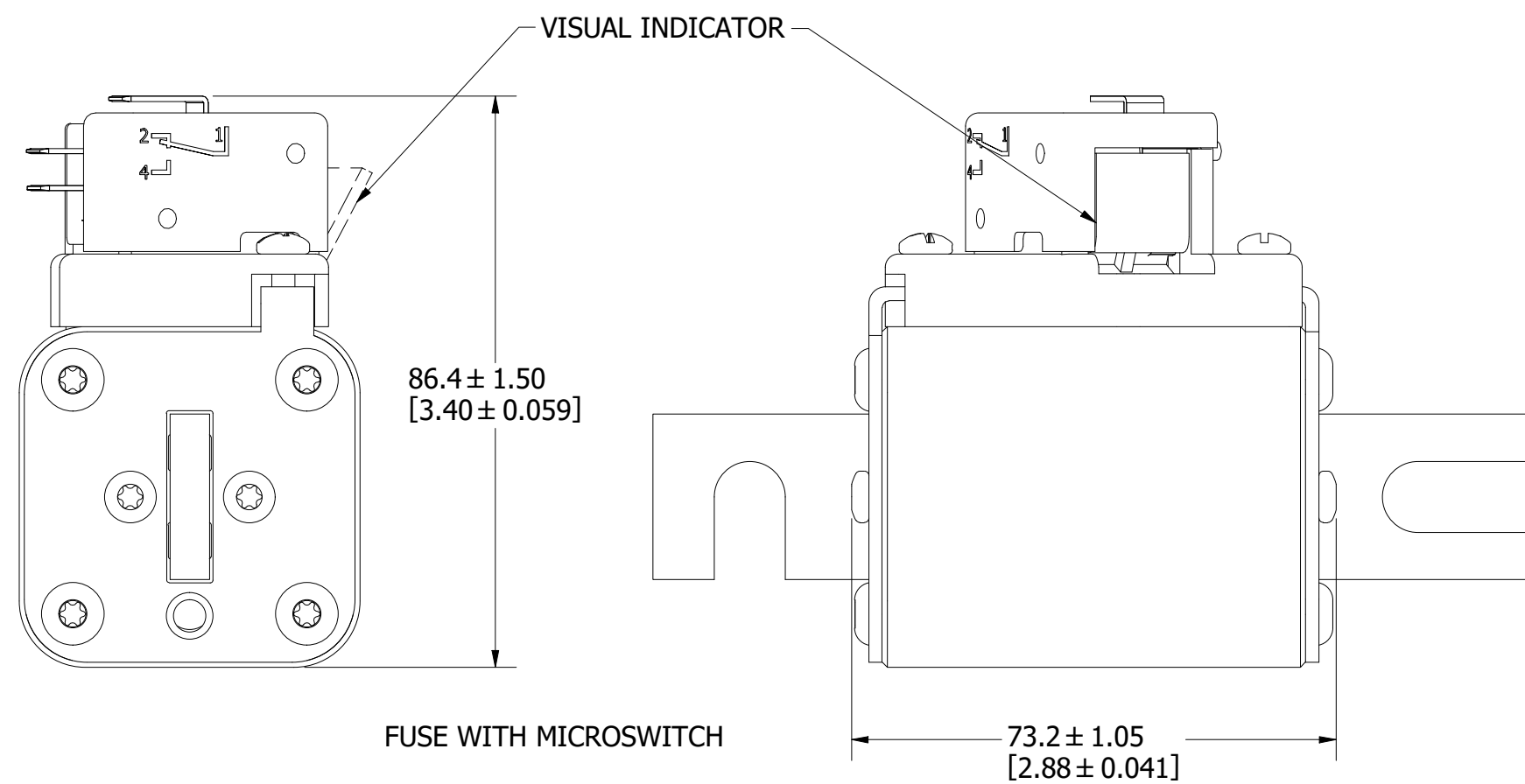
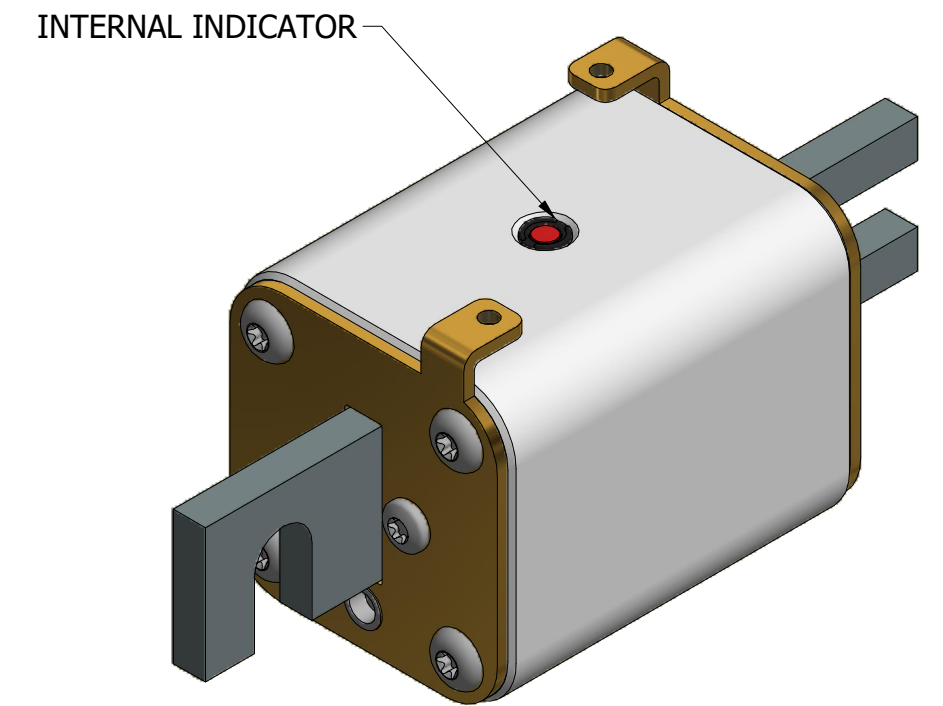

FUSE WITH MICROSWITCH

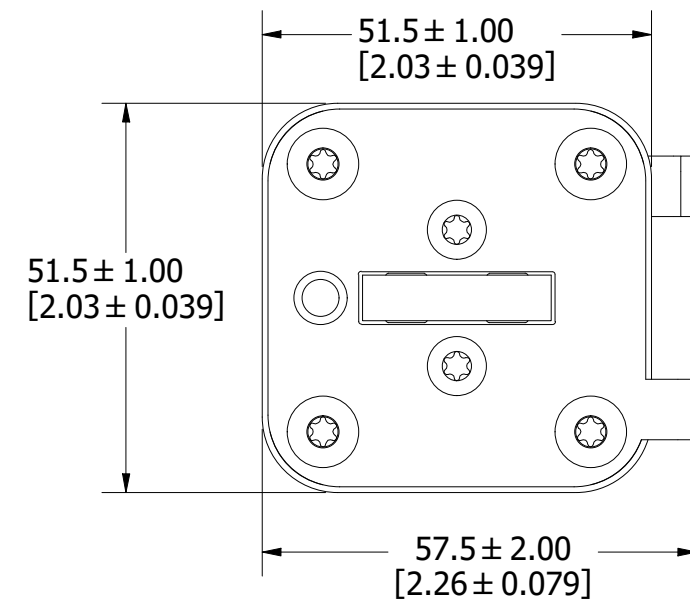

FOR REFERENCE ONLY

<S>	CRITICAL CHARACTERISTIC FOR PART SAFETY/COMPLIANCE		
●	DENOTES CRITICAL CHARACTERISTICS.		
CPK	DENOTES CPK DIMENSIONS, -MINIMUM CPK VALUE		
Ⓢ	DENOTES A CHARACTERISTIC THAT PROVIDES AN INDICATION OF PROCESS PERFORMANCE. PROCEDURE FOR MEASUREMENT AND TRACKING TO BE DEFINED IN LITTELFUSE INSPECTION INSTRUCTIONS.		
CP	DENOTES CP DIMENSIONS, -MINIMUM CP VALUE MUST BE WITHIN THE DIMENSIONAL LIMITATIONS SHOWN ON DRAWING AND INITIALLY LOCATED TO ALLOW FOR MAXIMUM TOOL LIFE.		
MATL SPEC		FINISH	
DRW myork	DATE 3/5/2020	SCALE NTS	FINISH GOOD WT GRAMS/PIECE
UNLESS OTHERWISE SPECIFIED, DIMENSIONS ARE IN MILLIMETERS, DIMENSIONS IN BRACKETS [] ARE INCHES DIMENSIONING AND DO NOT INCLUDE PLATING. TOLERANCING TO BE INTERPRETED IN ACCORDANCE WITH ANSI Y14.5M-1994			
3RD ANGLE PROJECTION			
TITLE PSR SIZE 71 DIN 110 (DL) FUSE OUTLINE			
Littelfuse® CHICAGO, ILLINOIS 60631		REVISION D	DRWG NO. OL-PSR071DL0000 SHEET 1 OF 1

MOUNTING SPECS:

RECOMMENDED FASTENER: M10 OR 3/8"
TIGHTENING TORQUE (REFERENCE ONLY): 26Nm

REVISION		
REV	DATE	DESCRIPTION
A	3/11/20	522093GCP - RELEASE MRY
B	4/20/20	522239ECP/D - ADD TOLERANCES MRY
C	5/11/22	525180ECP/D - CHANGE HEIGHT DIMENSION MRY
D	10/24/23	526836ECP/D - ADD VIEW W/O MICROSWITCH MRY

FUSE WITH MICROSWITCH

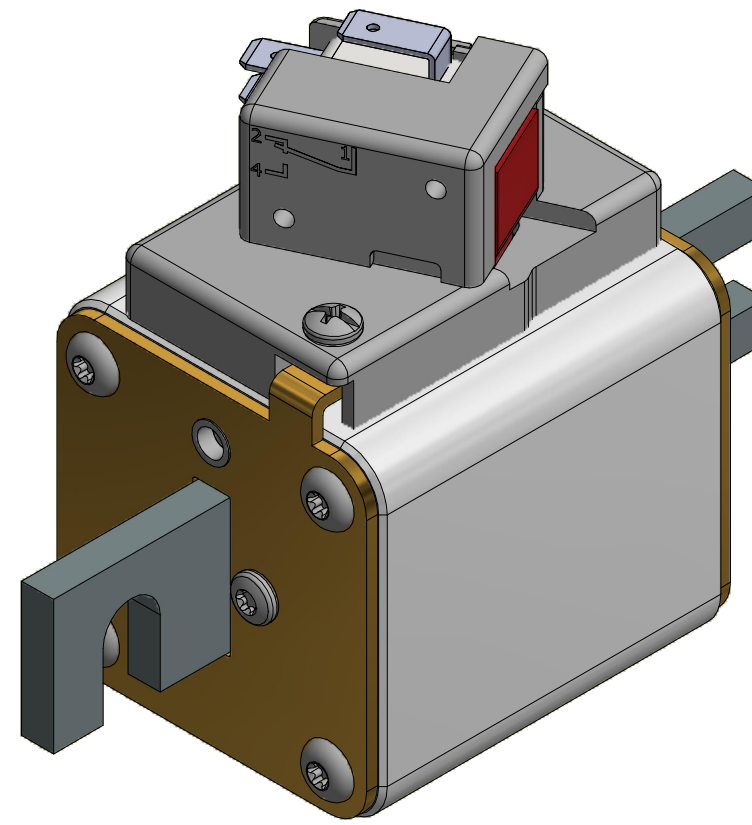
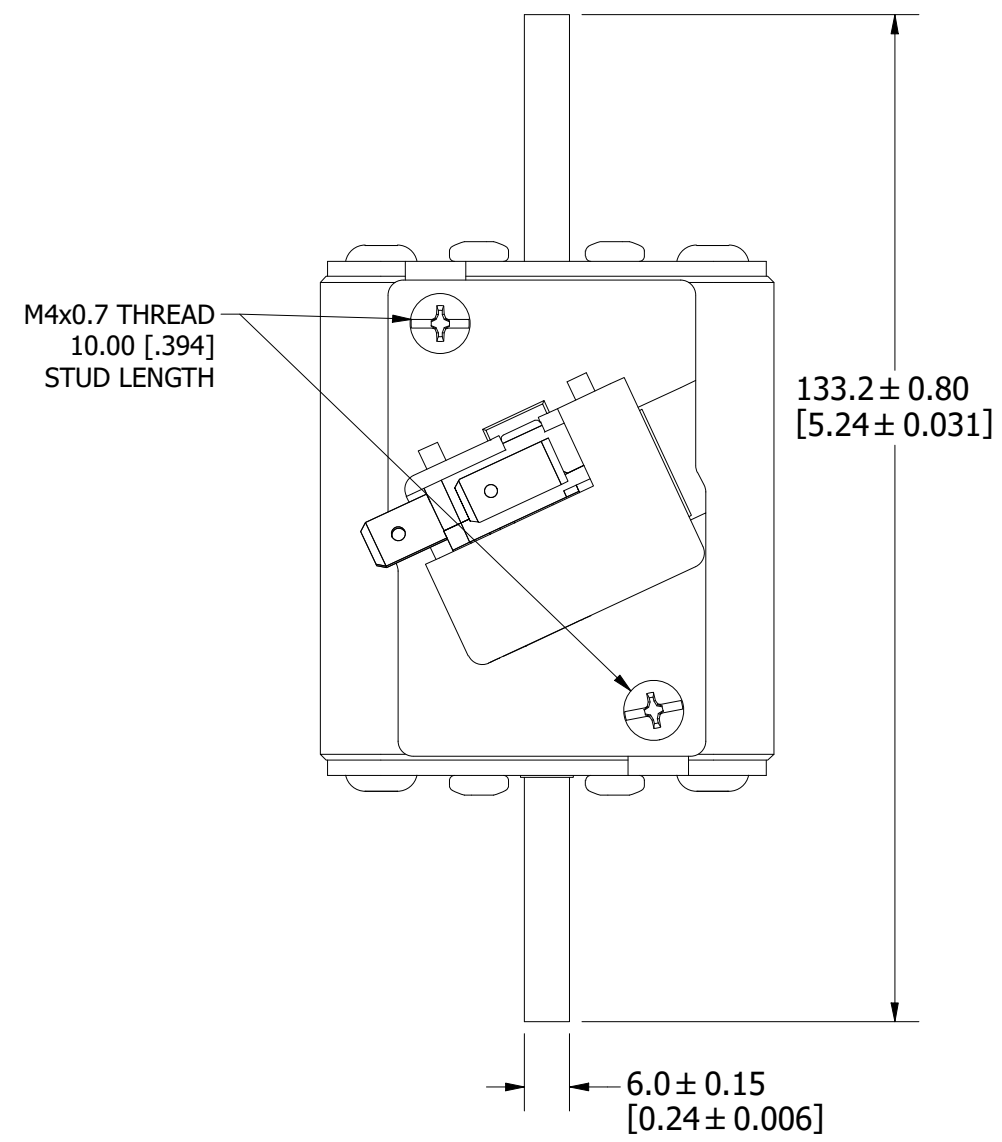

FUSE

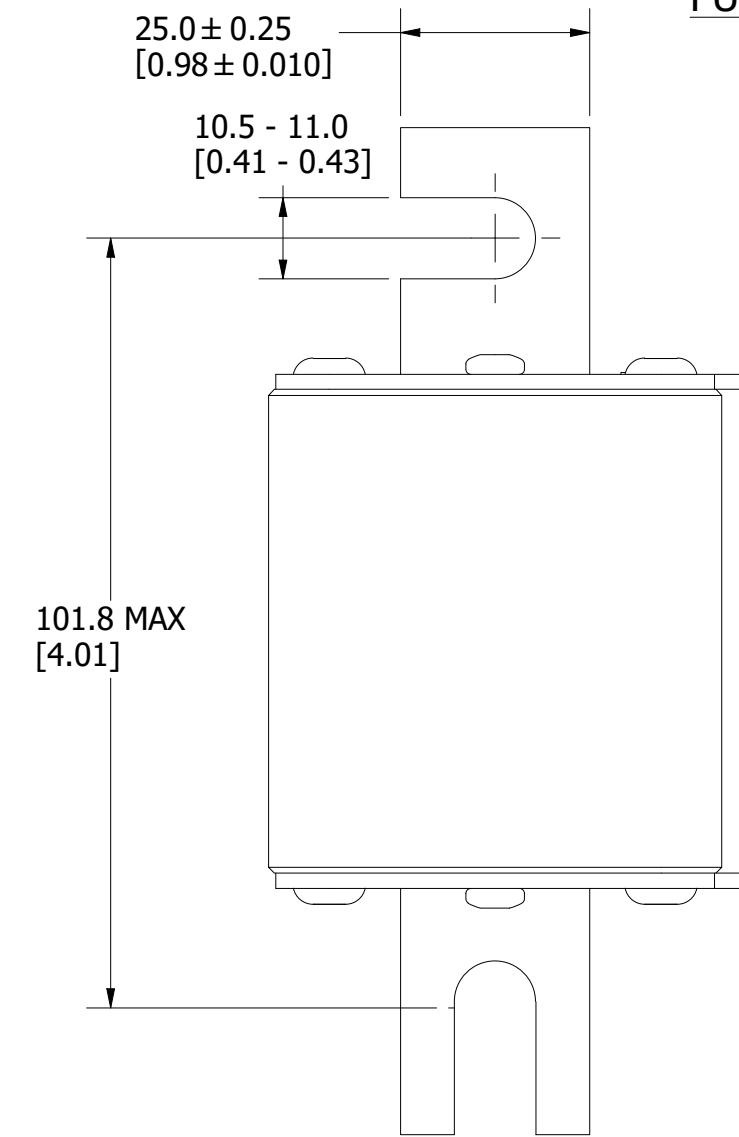

INTERNAL INDICATOR

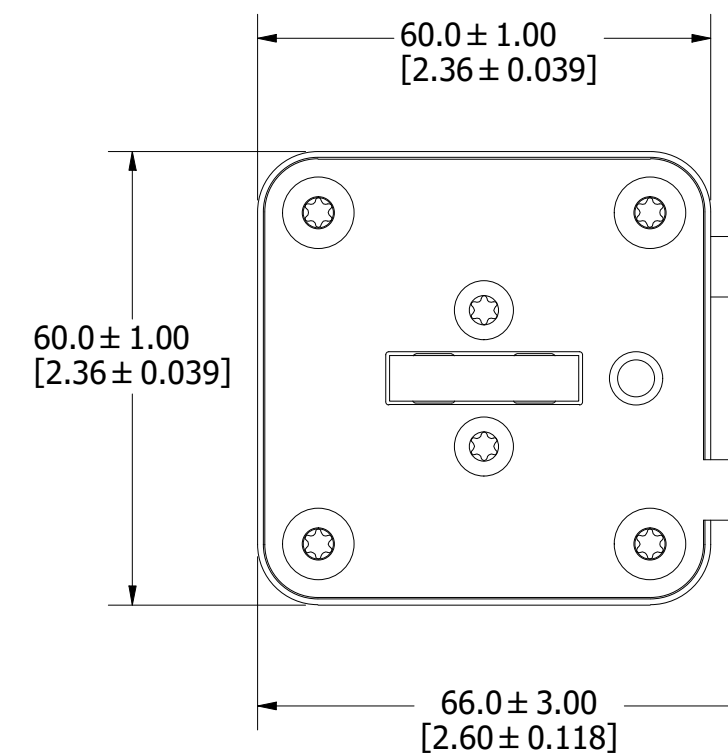
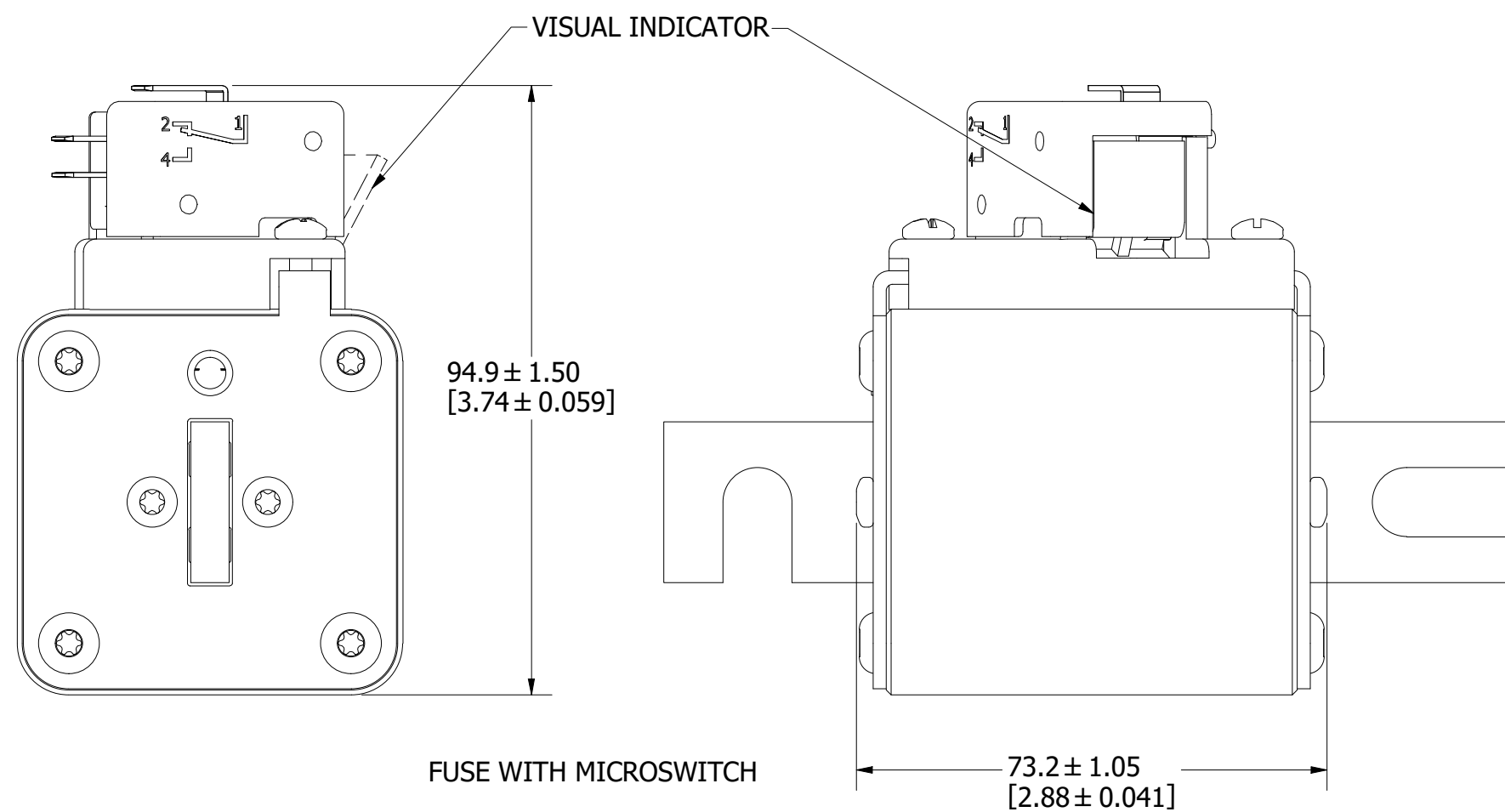
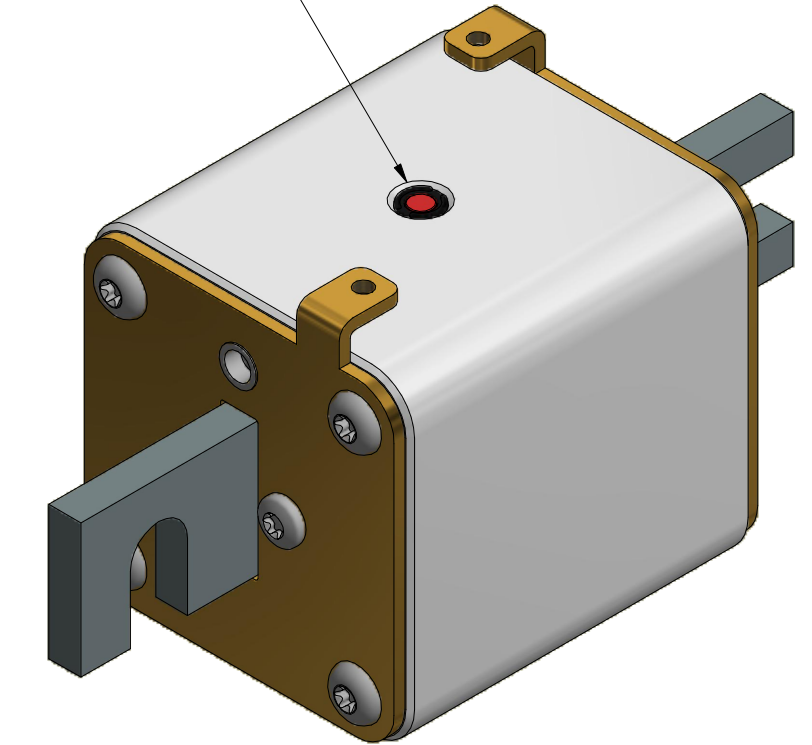

FOR REFERENCE ONLY

<S>	CRITICAL CHARACTERISTIC FOR PART SAFETY/COMPLIANCE
●	DENOTES CRITICAL CHARACTERISTICS.
CPK	DENOTES CPK DIMENSIONS, -MINIMUM CPK VALUE
Ⓢ	DENOTES A CHARACTERISTIC THAT PROVIDES AN INDICATION OF PROCESS PERFORMANCE. PROCEDURE FOR MEASUREMENT AND TRACKING TO BE DEFINED IN LITTELFUSE INSPECTION INSTRUCTIONS.
CP	DENOTES CP DIMENSIONS, -MINIMUM CP VALUE MUST BE WITHIN THE DIMENSIONAL LIMITATIONS SHOWN ON DRAWING AND INITIALLY LOCATED TO ALLOW FOR MAXIMUM TOOL LIFE.

MATL SPEC	FINISH
DRW myork	DATE 3/5/2020
SCALE NTS	FINISH GOOD WT GRAMS/PIECE

UNLESS OTHERWISE SPECIFIED, DIMENSIONS ARE IN MILLIMETERS, DIMENSIONS IN BRACKETS [] ARE INCHES DIMENSIONING AND DO NOT INCLUDE PLATING. TOLERANCING TO BE INTERPRETED IN ACCORDANCE WITH ANSI Y14.5M-1994

3RD ANGLE PROJECTION	
----------------------	--

TITLE PSR SIZE 72 DIN 110 (DL) FUSE OUTLINE

MOUNTING SPECS:

RECOMMENDED FASTENER: M10 OR 3/8"
TIGHTENING TORQUE (REFERENCE ONLY): 26Nm

REVISION		
REV	DATE	DESCRIPTION
A	3/11/20	522093GCP - RELEASE MRY
B	4/20/20	522239ECP/D - ADD TOLERANCES MRY
C	5/11/22	525180ECP/D - CHANGE HEIGHT DIMENSION MRY
D	10/24/23	526836ECP/D - ADD VIEW W/O MICROSWITCH MRY

FUSE WITH MICROSWITCH

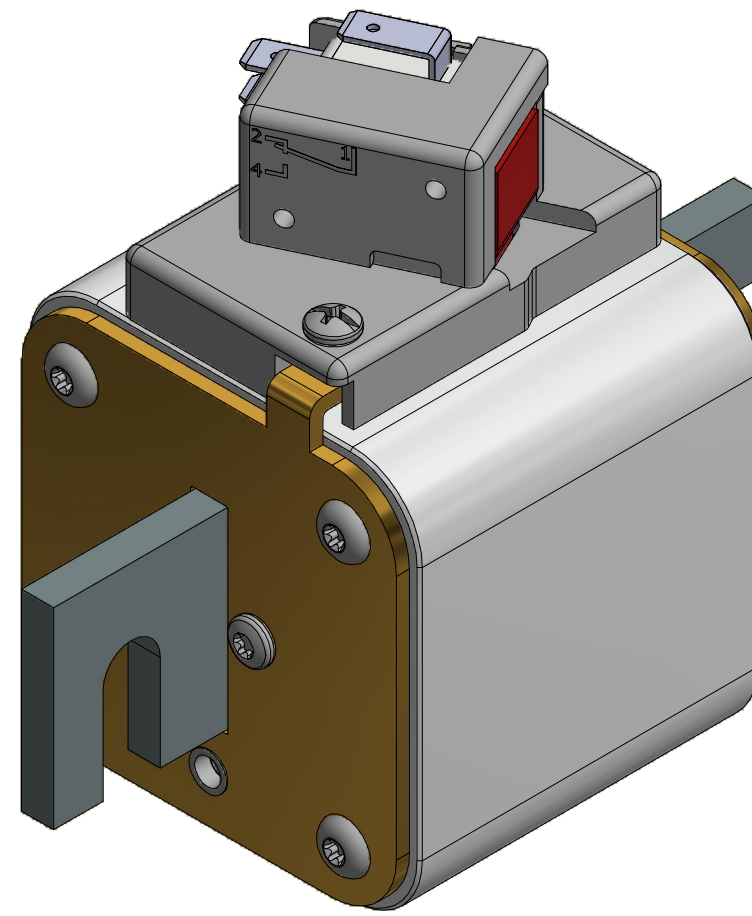
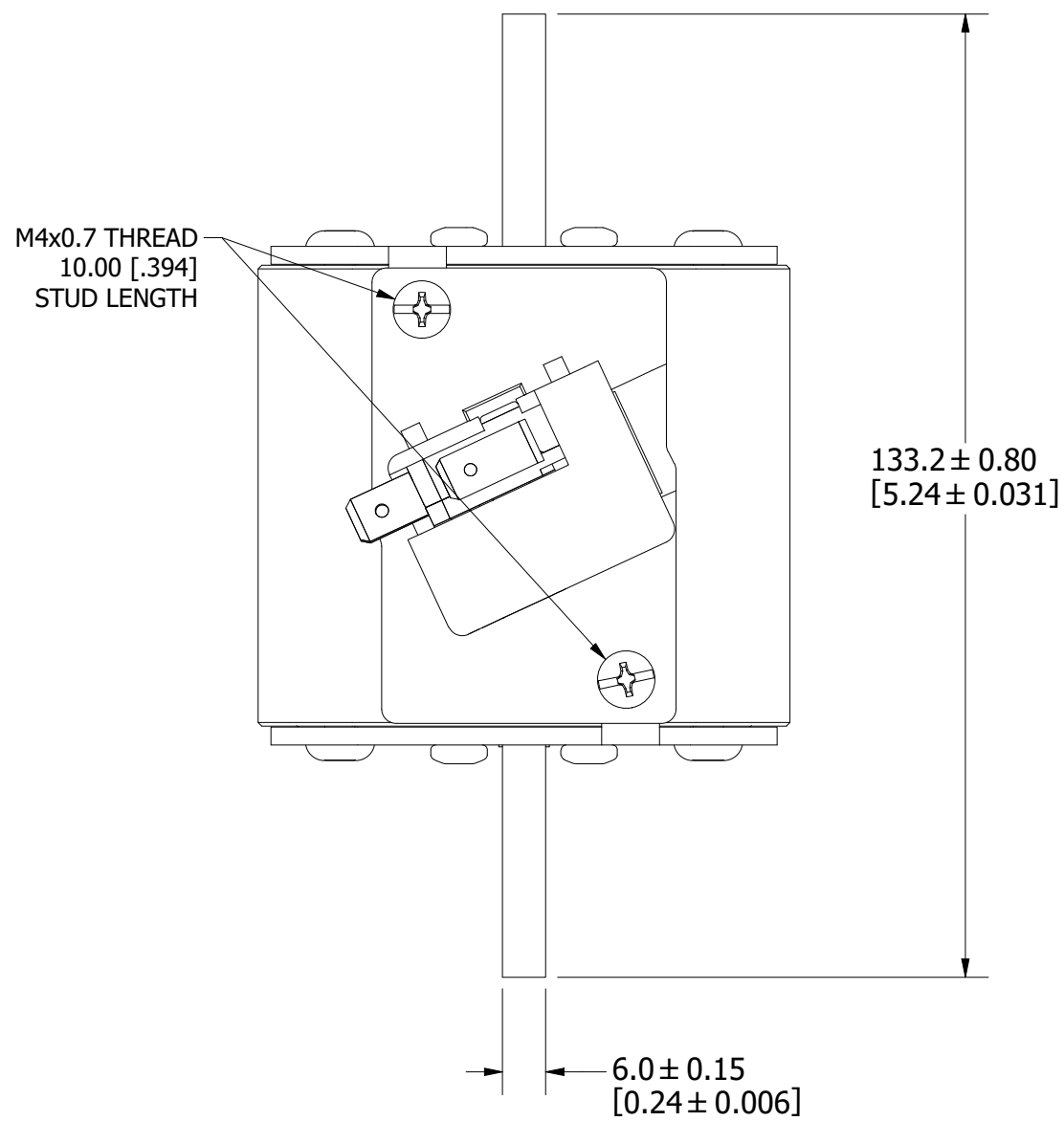

FUSE

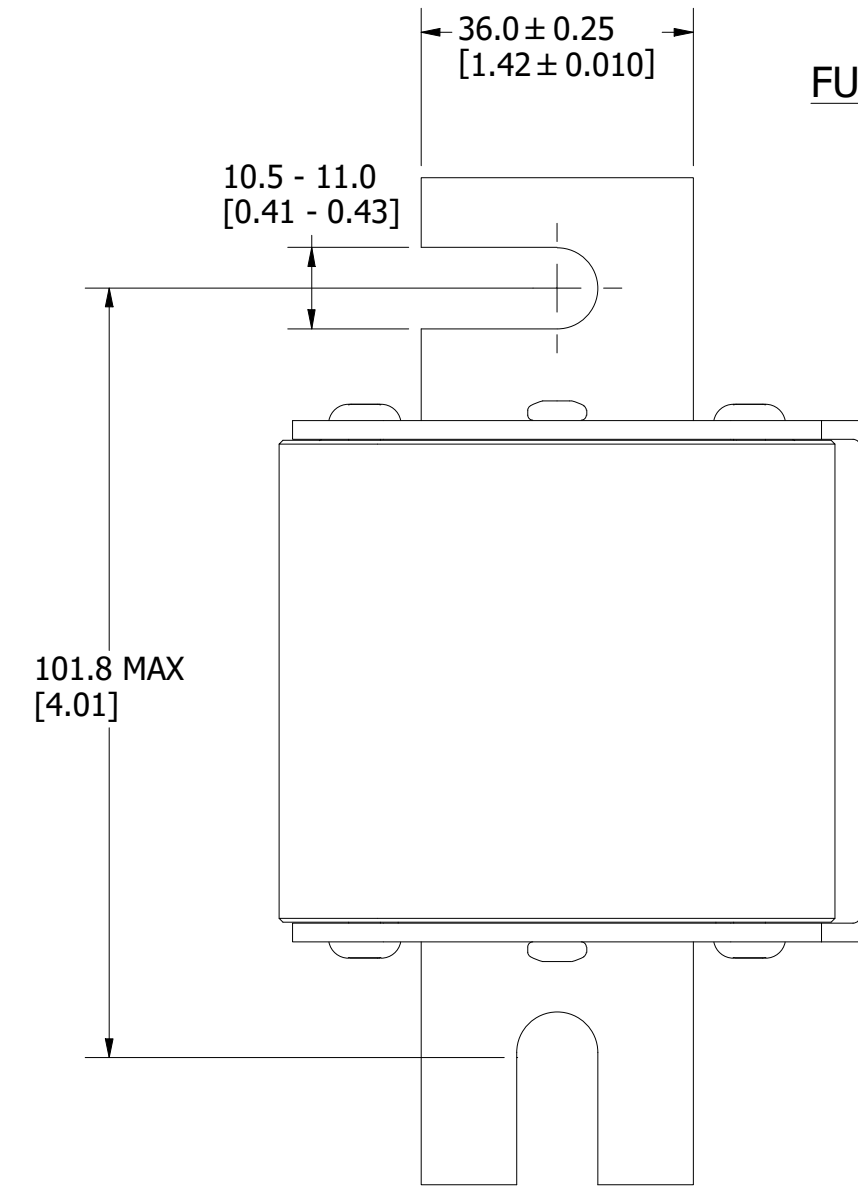

INTERNAL INDICATOR

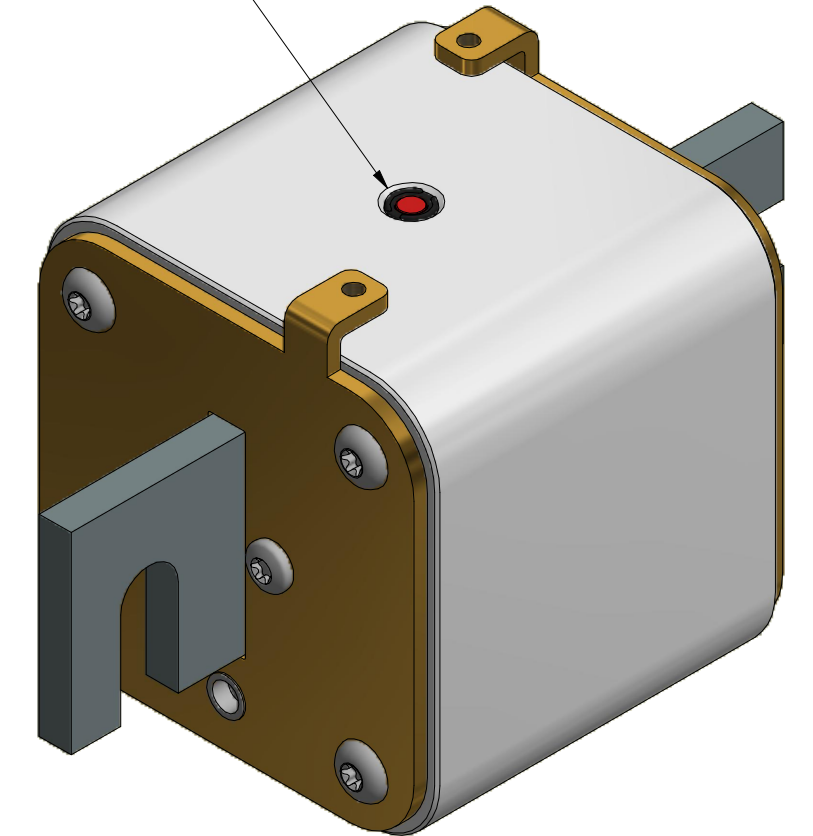

VISUAL INDICATOR

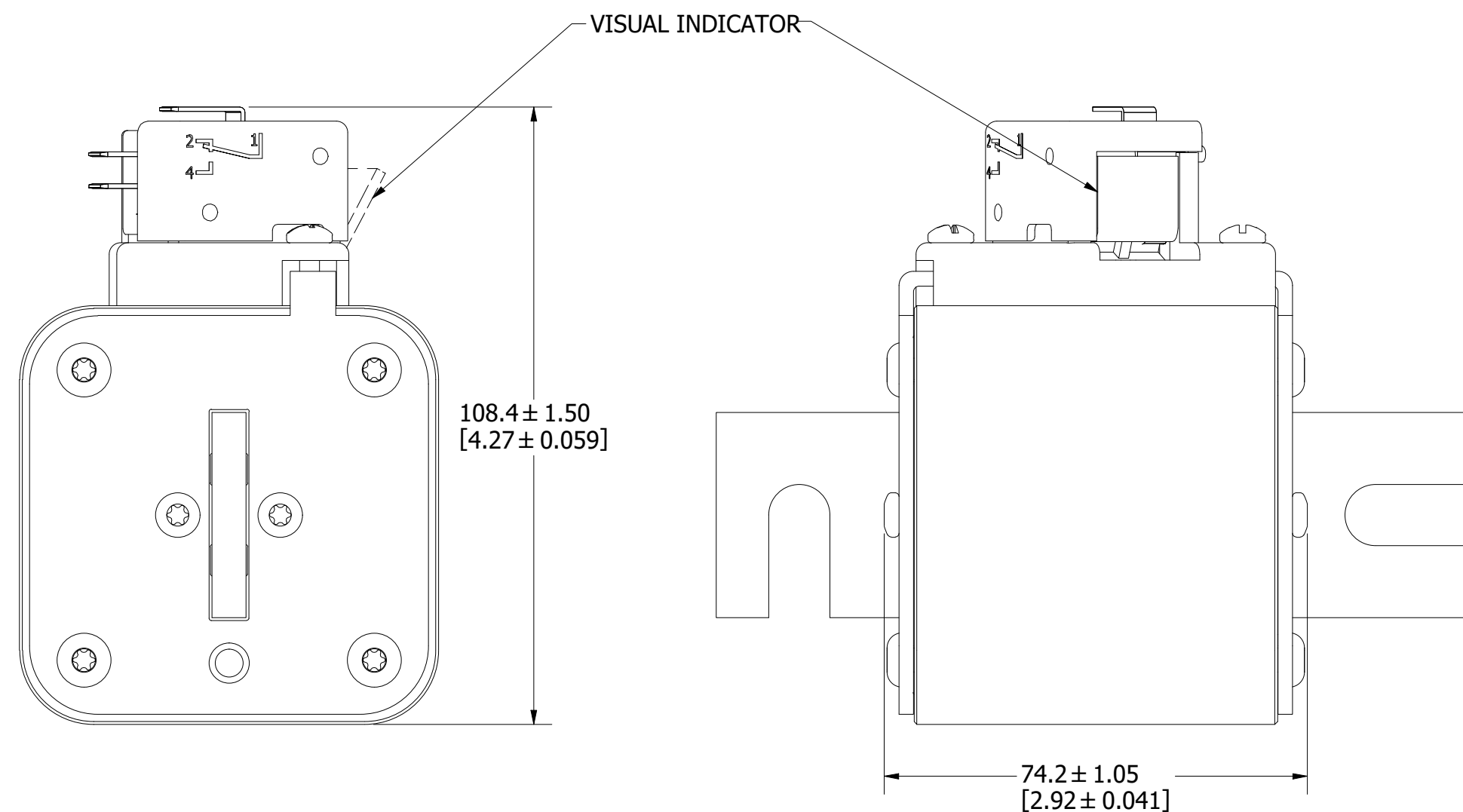

FUSE WITH MICROSWITCH

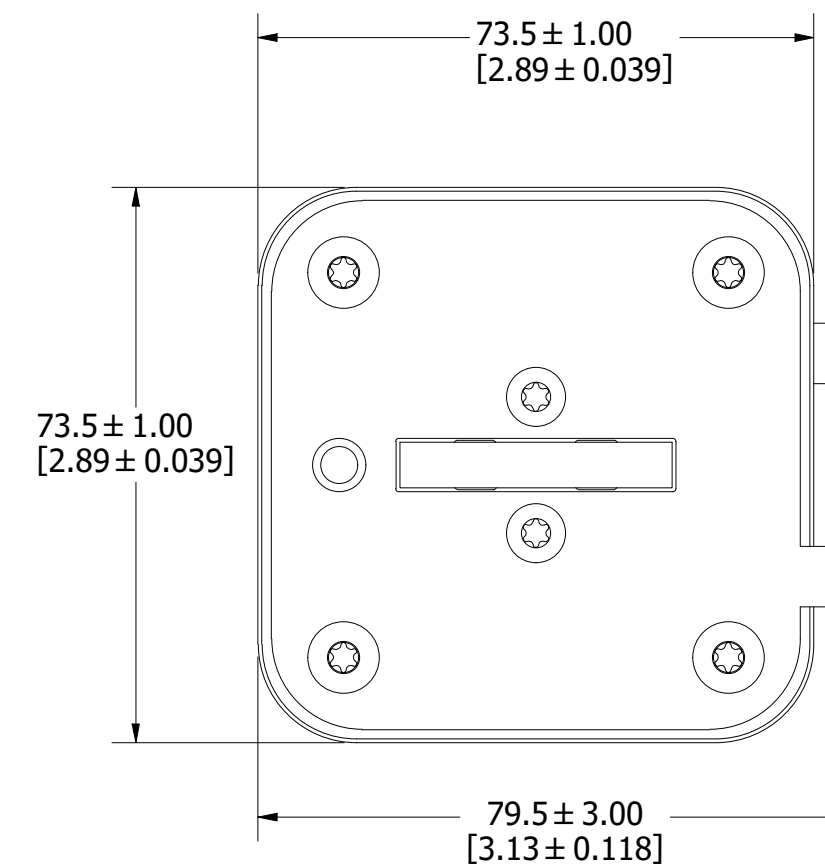

FOR REFERENCE ONLY

<S>	CRITICAL CHARACTERISTIC FOR PART SAFETY/COMPLIANCE
●	DENOTES CRITICAL CHARACTERISTICS.
CPK	DENOTES CPK DIMENSIONS, -MINIMUM CPK VALUE
Ⓢ	DENOTES A CHARACTERISTIC THAT PROVIDES AN INDICATION OF PROCESS PERFORMANCE. PROCEDURE FOR MEASUREMENT AND TRACKING TO BE DEFINED IN LITTELFUSE INSPECTION INSTRUCTIONS.
CP	DENOTES CP DIMENSIONS, -MINIMUM CP VALUE MUST BE WITHIN THE DIMENSIONAL LIMITATIONS SHOWN ON DRAWING AND INITIALLY LOCATED TO ALLOW FOR MAXIMUM TOOL LIFE.

MATL SPEC	FINISH
DRW myork	DATE 2/24/2020
SCALE NTS	FINISH GOOD WT GRAMS/PIECE

UNLESS OTHERWISE SPECIFIED, DIMENSIONS ARE IN MILLIMETERS, DIMENSIONS IN BRACKETS [] ARE INCHES DIMENSIONING AND DO NOT INCLUDE PLATING. TOLERANCING TO BE INTERPRETED IN ACCORDANCE WITH ANSI Y14.5M-1994

3RD ANGLE PROJECTION	
----------------------	--

TITLE PSR SIZE 73 DIN 110 (DL) FUSE OUTLINE

Littelfuse CHICAGO, ILLINOIS 60631	REVISION D	DRWG NO. OL-PSR073DL0000	SHEET 1 OF 1
--	------------	--------------------------	--------------