

SMCLCE-HR Series

1500 W Low Capacitance Surface Mount in DO-214AB



Agency Approvals

Agency	Agency File Number
	E230531

Maximum Ratings & Thermal Characteristics (T_A = 25 °C unless otherwise noted)

Parameter	Symbol	Value	Unit
Peak Pulse Power Dissipation by 10/1000 μ s Waveform (Fig.1)(Note 1)	P _{PPM}	1500	W
Power Dissipation on Infinite Heat Sink at T _L = 50 °C	P _D	6.5	W
Operating Temperature Range	T _J	-65 to 150	°C
Storage Temperature Range	T _{STG}	-65 to 175	°C

Notes:

1. Non-repetitive current pulse, per Fig. 3 and derated above T_J (initial) = 25 °C per Fig. 2.

Description

SMCLCE-HR high reliability series is designed specifically to protect sensitive data line electronic equipment from voltage transients induced by lightning and other transient voltage events.

Features

- Low capacitance ≤ 50 pF, 1500 W peak pulse power capability at 10/1000 μ s waveform, repetition rate (duty cycles):0.01 %
- For surface mounted applications in order to optimize board space
- Low profile package
- Built-in strain relief
- Typical failure mode is short from over-specified voltage or current
- Whisker test is conducted based on JEDEC JESD201A per its table 4a and 4c
- ESD protection of data lines in accordance with IEC 61000-4-2 ESD 30 kV (Air), 30 kV (Contact)
- EFT protection of data lines in accordance with IEC 61000-4-4
- Glass passivated chip junction
- Low incremental surge resistance
- Fast response and excellent clamping capability
- UL recognized compound meeting flammability rating V-0
- Meet MSL level1, per J-STD-020, high temperature soldering guaranteed:260 °C/10 seconds at terminals
- Matte tin lead-free plated
- Halogen free and RoHS compliant
- Pb-free E3 means 2nd level interconnect is Pb-free and the terminal finish material is tin(Sn) (IPC/JEDEC J-STD-609A.01)

Applications

- I/O Interfaces for avionics applications, such as flight control, FADEC, radar, and etc.
- Protection for aircraft fast data line

Schematic

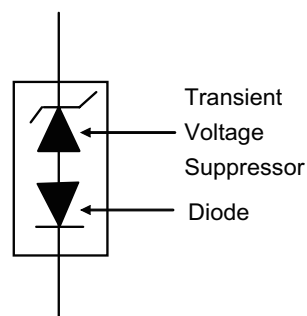

SMCLCE-HR Series

1500 W Low Capacitance Surface Mount in DO-214AB

Electrical Characteristics

Part Number (Uni)	Marking Code	Stand-Off Voltage V_R (V)	Minimum Breakdown Voltage $V_{BR}(V)$ @ I_T		Test Current I_T (mA)	Maximum Reverse Leakage at I_R @ V_R (μA)	Maximum Clamping Voltage @ I_{PP} V_C (V)	Maximum Peak Pulse Current per (Fig.3) I_{PP} (A)	Maximum Junction Capacitance at 0 Volts $f = 1$ MHz (pF)	Working Inverse Blocking Voltage V_{WIB} (V)	Inverse Blocking Leakage Current at I_{IB} @ V_{WIB} (mA)	Peak Inverse Blocking Voltage V_{PIB} (V)	Agency Approval 
			Min	Max									
SMCLCE12-HR	SGEE	12	13.3	14.7	1	5	20.9	75.4	50	75	1.0	100	X
SMCLCE13-HR	SGEG	13	14.4	15.9	1	3	22.5	69.8	50	75	1.0	100	X
SMCLCE14-HR	SGEK	14	15.6	17.2	1	3	24.2	64.7	50	75	1.0	100	X
SMCLCE15-HR	SGEM	15	16.7	18.5	1	0.96	25.4	61.5	50	75	1.0	100	X
SMCLCE16-HR	SGEP	16	17.8	19.7	1	0.96	27.0	57.7	50	75	1.0	100	X
SMCLCE17-HR	SGER	17	18.9	20.9	1	0.96	28.6	54.4	50	75	1.0	100	X
SMCLCE18-HR	SGET	18	20.0	22.1	1	0.96	30.2	51.4	50	75	1.0	100	X
SMCLCE20-HR	SGEV	20	22.2	24.5	1	0.96	33.4	46.3	50	75	1.0	100	X
SMCLCE22-HR	SGEX	22	24.4	26.9	1	0.96	36.5	42.3	50	75	1.0	100	X
SMCLCE24-HR	SGEZ	24	26.7	29.5	1	0.96	39.9	38.6	50	75	1.0	100	X
SMCLCE26-HR	SGFE	26	28.9	31.9	1	0.96	43.1	35.7	50	75	1.0	100	X
SMCLCE28-HR	SGFG	28	31.1	34.4	1	0.96	46.5	33.1	50	75	1.0	100	X
SMCLCE30-HR	SGFK	30	33.3	36.8	1	0.96	49.4	31.0	50	75	1.0	100	X
SMCLCE33-HR	SGFM	33	36.7	40.6	1	0.96	53.3	28.2	50	75	1.0	100	X
SMCLCE36-HR	SGFP	36	40.0	44.2	1	0.96	58.1	25.9	50	75	1.0	100	X
SMCLCE40-HR	SGFR	40	44.4	49.1	1	0.96	64.5	23.3	50	75	1.0	100	X
SMCLCE43-HR	SGFT	43	47.8	52.8	1	0.96	69.4	21.7	50	75	1.0	100	X
SMCLCE45-HR	SGFV	45	50.0	55.3	1	0.96	72.7	20.6	50	75	1.0	100	X
SMCLCE48-HR	SGFX	48	53.3	58.9	1	0.96	77.4	19.4	50	75	1.0	100	X
SMCLCE51-HR	SGFZ	51	56.7	62.7	1	0.96	82.4	18.2	50	75	1.0	100	X
SMCLCE54-HR	SGGE	54	60.0	66.3	1	0.96	87.1	17.3	50	100	1.0	125	X
SMCLCE58-HR	SGGG	58	64.4	71.2	1	0.96	93.6	16.1	50	100	1.0	125	X
SMCLCE60-HR	SGGK	60	66.7	73.7	1	0.96	96.8	15.5	50	100	1.0	125	X
SMCLCE64-HR	SGGM	64	71.1	78.6	1	0.96	103.0	14.6	50	100	1.0	125	X
SMCLCE70-HR	SGGP	70	77.8	86.0	1	0.96	113.0	13.3	50	125	1.0	150	X

Note: Each lot of parts will pass group B test requirement.

Screen Process

100 % vision inspection	MIL-STD-750 method 2074
100 % X-RAY inspection	MIL-STD-750 method 2076
100 % temperature cycle test (-55 °C to 150 °C, 20 cycles, dwell time 15 min)	MIL-STD-750 method 1051
100 % reflow (2x)	JEDEC J-STD-020
100 % surge test (2x)	MIL-STD-750 method 4066
100 % HTRB 150 °C bias = V_R (80 % breakdown voltage, 96 hrs)	MIL-STD-750 method 1038
Final electrical test (100 % 3 sigma limit, 100 % dynamic test and PAT limit)	MIL-STD-750 method 4016.4021.4011

Note: Up-screen program can be specified by customer's request by contacting Littelfuse customer service

SMCLCE-HR Series

1500 W Low Capacitance Surface Mount in DO-214AB

Group B Test Requirement

Screen	Method	Condition	Requirement
Surge test	10/1000 μ s peak pulse waveform	Maximum clamping voltage (V_C) @ peak pulse current (I_{PP})	Sample size 45 perform 10x Accept 0 failures
Burn-in (HTRB)	MIL-STD-750, method 1038.5	Applied voltage 100 % V_R @150 °C	Sample size 45 340 hours Accept 0 failures
Electrical test	--	I_R @ V_R , $V_{(BR)}$ @ I_T	Sample size 45 Accept 0 failures

Ratings and Characteristic Curves ($T_A = 25$ °C unless otherwise noted)**Figure 1 - Peak Pulse Power Rating Curve****Figure 2 - Peak Pulse Power Derating Curve****Figure 3 - Pulse Waveform****Figure 4 - AC Line Protection Application**

SMCLCE-HR Series

1500 W Low Capacitance Surface Mount in DO-214AB

Soldering Parameters

Reflow Condition		Lead-free assembly
Pre Heat	- Temperature Min ($T_{s(min)}$)	150 °C
	- Temperature Max ($T_{s(max)}$)	200 °C
	- Time (min to max) (t_s)	60 – 180 seconds
Average Ramp Up Rate (Liquidus Temp (T_L) to Peak)		3 °C/second max
$T_{s(max)}$ to T_L - Ramp-up Rate		3 °C/second max
Reflow	- Temperature (T_L) (Liquidus)	217 °C
	- Time (min to max) (t_s)	60 – 150 seconds
Peak Temperature (T_p)		260 ^{+0/-5} °C
Time Within 5 °C of Actual Peak Temperature (t_p)		20 – 40 seconds
Ramp-down Rate		6 °C/second max
Time 25 °C to Peak Temperature (T_p)		8 minutes max
Do Not Exceed		260 °C



Physical Specifications

Weight	0.003oz., 0.093g
Case	JEDEC DO-214AB molded plastic body over glass passivated junction.
Polarity	Color band denotes cathode except bidirectional
Terminal	Matte Tin-plated leads. Solderable per JESD22-B102

Environmental Specifications

High Temperature Storage	JESD22-A103
HTRB	JESD22-A108
Temperature Cycling	JESD22-A104
MSL	JEDEC-J-STD-020, Level 1
H3TRB	JESD22-A101
RSH	JESD22-A111

Dimensions

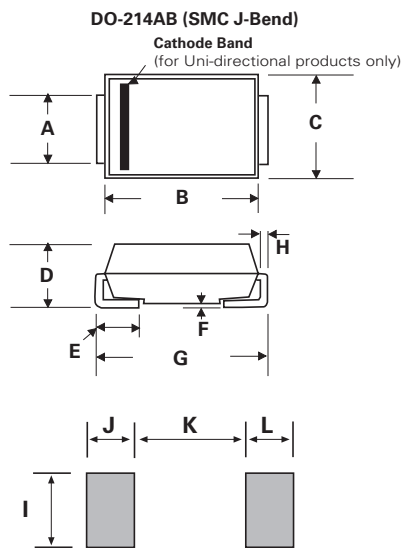

Recommended Soldering Pad Layout

Dimensions	Inches		Millimeters	
	Min	Max	Min	Max
A	0.114	0.126	2.900	3.200
B	0.260	0.280	6.600	7.110
C	0.220	0.245	5.590	6.220
D	0.079	0.103	2.060	2.620
E	0.030	0.060	0.760	1.520
F	-	0.008	-	0.203
G	0.305	0.320	7.750	8.130
H	0.006	0.012	0.152	0.305
I	0.129	-	3.300	-
J	0.094	-	2.400	-
K	-	0.165	-	4.200
L	0.094	-	2.400	-

SMCLCE-HR Series

1500 W Low Capacitance Surface Mount in DO-214AB

Part Numbering System

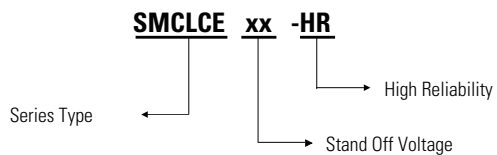

Part Marking System

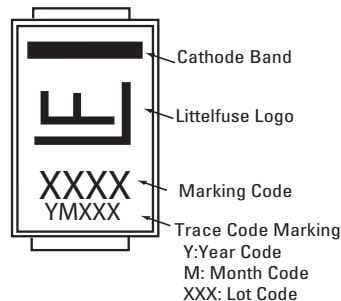

Packaging

Part number	Component Package	Quantity	Packaging Option	Packaging Specification
SMCLCExx-HR	DO-214AB	500	Tape & Reel - 16 mm tape/7" reel	EIA STD RS-481

Tape and Reel Specification

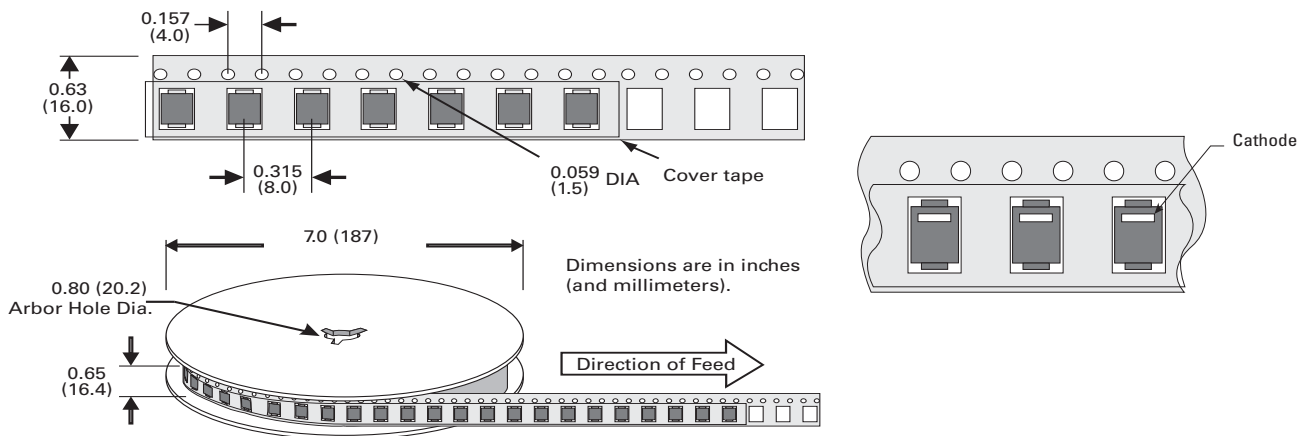

SMCLCE-HR Series

1500 W Low Capacitance Surface Mount in DO-214AB

RTCA/DO-160G Wave 3



RTCA/DO-160G Wave 4



RTCA/DO-160G Wave 5



Pin Injection Protection Per RTCA/DO-160G

Part Number	25 °C						70 °C						120 °C											
	Wave 3		Wave 4 (6.4/69 μs)				Wave 5a (40/120 μs)		Wave 3		Wave 4 (6.4/69 μs)				Wave 5a (40/120 μs)		Wave 3		Wave 4 (6.4/69 μs)				Wave 5a (40/120 μs)	
	L5	L3	L4	L5	L3	L4	L5	L3	L4	L5	L3	L4	L5	L3	L4	L5	L3	L4	L5	L3	L4	L5		
SMCLCE12-HR	pass	pass	pass	pass	pass	pass	-	pass	pass	pass	pass	pass	pass	-	pass	pass	pass	pass	pass	-	-	-		
SMCLCE13-HR	pass	pass	pass	pass	pass	pass	-	pass	pass	pass	pass	pass	pass	-	pass	pass	pass	pass	pass	-	-	-		
SMCLCE28-HR	pass	pass	pass	-	-	-	pass	pass	pass	-	-	-	pass	pass	pass	-	-	-	-	-	-	-		

Note:
 1. L1 = Level 1, L2 = Level 2, L3 = Level 3, L4 = Level 4, L5 = Level 5

Disclaimer Notice - Information furnished is believed to be accurate and reliable. However, users should independently evaluate the suitability of and test each product selected for their own applications. Littelfuse products are not designed for, and may not be used in, all applications. Read complete Disclaimer Notice at <http://www.littelfuse.com/disclaimer-electronics>.

