

REVISION		
REV	DATE	DESCRIPTION
A	8/10/22	525550GCP - RELEASE MRY

$\varnothing 10.3 \pm .10$
 $[\varnothing .406 \pm .004]$

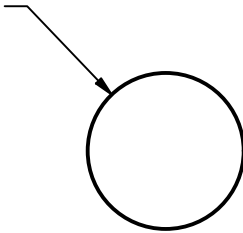

APPROXIMATE SHIPPING WEIGHT: 10 FUSES / 0.17 LBS.

$38.1 \pm .79$
 $[1.500 \pm .031]$

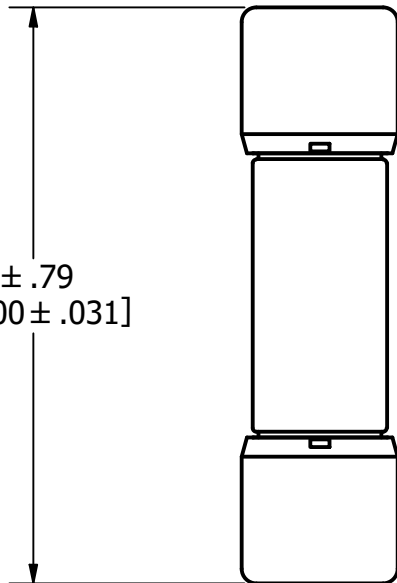

1				
NO	COMPONENT NO	DESCRIPTION	QTY/M	U/M

BILL OF MATERIAL

<S>	CRITICAL CHARACTERISTIC FOR PART SAFETY/COMPLIANCE
●	DENOTES CRITICAL CHARACTERISTICS.
CPK	DENOTES CPK DIMENSIONS, -MINIMUM CPK VALUE
⊠	DENOTES A CHARACTERISTIC THAT PROVIDES AN INDICATION OF PROCESS PERFORMANCE. PROCEDURE FOR MEASUREMENT AND TRACKING TO BE DEFINED IN LITTELFUSE INSPECTION INSTRUCTIONS.
CP	DENOTES CP DIMENSIONS, -MINIMUM CP VALUE MUST BE WITHIN THE DIMENSIONAL LIMITATIONS SHOWN ON DRAWING AND INITIALLY LOCATED TO ALLOW FOR MAXIMUM TOOL LIFE.

A

MATL SPEC		FINISH	
DRW JMoler	DATE 8/9/2022	SCALE NTS	FINISH GOOD WT GRAMS/PIECE

UNLESS OTHERWISE SPECIFIED, DIMENSIONS ARE IN MILLIMETERS, DIMENSIONS IN BRACKETS [] ARE INCHES DIMENSIONING AND DO NOT INCLUDE PLATING. TOLERANCING TO BE INTERPRETED IN ACCORDANCE WITH ANSI Y14.5M-1994

3RD ANGLE PROJECTION	

TITLE KLKD 1/10-30A OUTLINE



REVISION	DRWG NO.	SHEET 1 OF 1
A	OL-KLKD030	