

THIS DRAWING AND THE INFORMATION CONTAINED WITHIN IT ARE CONFIDENTIAL AND MAY NOT BE COPIED OR DISCLOSED WITHOUT THE WRITTEN PERMISSION OF LITTELFUSE.

REVISIONS				
ZONE	REV.	DESCRIPTION	DATE	APPROVED
	A	GCF #522780, OL DRAWING RELEASE	9/7/2020	L ARGIL

SPECIFICATION NOTES:

1. RATING: LF MAXI FUSE UP TO 60A AT 20°C AMBIENT TEMPERATURE
2. CABLE CROSS-SECTIONS IN MM<sup>2</sup>: 2.5, 4, 6 AND 10
3. MAX TEMPERATURE, AT RATED CURRENT AND 20°C AMBIENT, OF HOTTEST POINT OF THE FUSEHOLDER BODY IS 110°C AT HIGHER AMBIENT THE AMPACITY IS DETERMINED BY THE ABOVE VALUE OF 110°C
4. MAXIMUM NUMBER OF FUSEBLOCKS TIED TOGETHER, IS TWO FOR ALL FUSE RATINGS UP TO 50A
5. DISENGAGE/LOADING FORCES FOR FUSEHOLDER WITH LF MAXI FUSE: MAX 60N

SPECIFICATION PARTS:

1. RECOMMENDED TERMINALS:  
2.5-6 MM<sup>2</sup> PARTNUMBER 913653 ACCORDING TO DIN 46234 5-6  
6-10 MM<sup>2</sup> PARTNUMBER 91354 ACCORDING TO DIN 46234 5-10
2. RECOMMENDED SCREWS:  
M5X8 PARTNUMBER 913550 ACCORDING TO DIN 7985-4-8 FeZn8cc

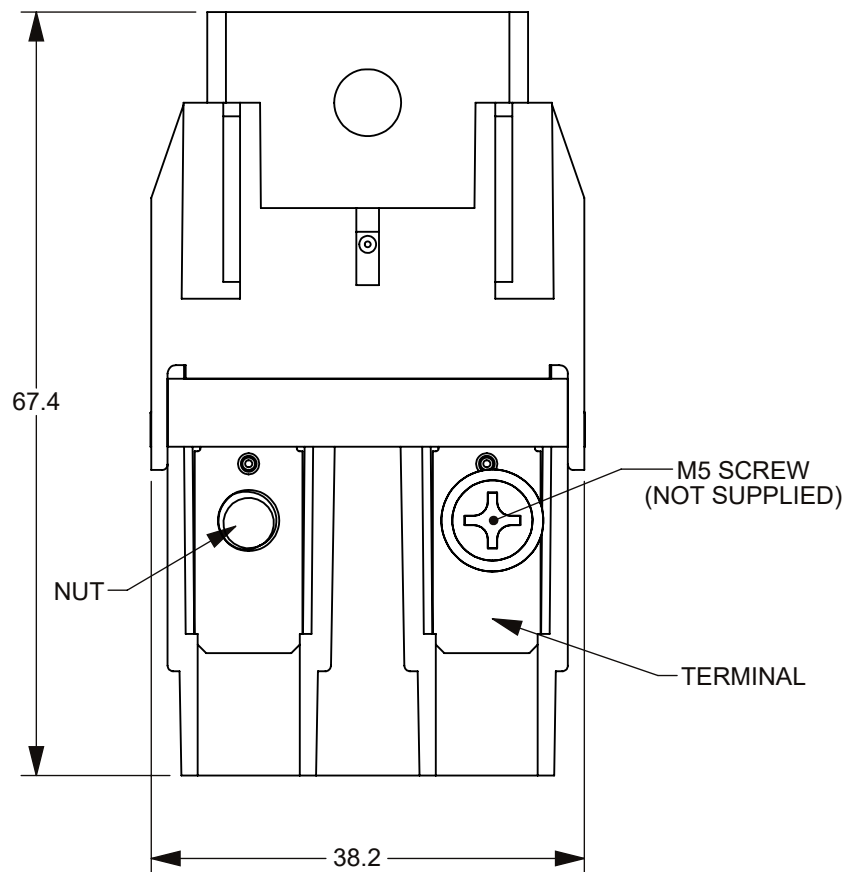
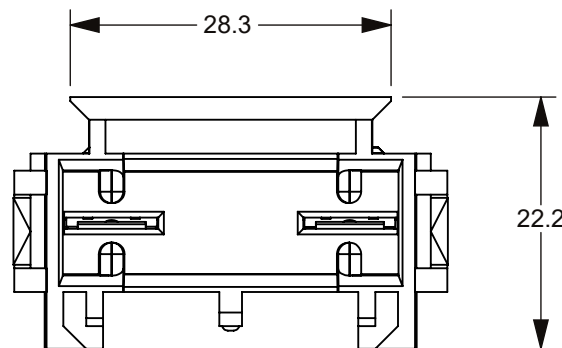

3	NUT	CuZn 39Pb3	2
2	TERMINAL	CuFe 2P (K65)	2
1	BODY	PA66 GF30 COLOR: BLACK UL94V2	1
NO.	DESCRIPTION	MATERIAL	QTY/M

●		FIT/ FUNCTION CRITICAL CHARACTERISTICS SYMBOL
<S>		SAFETY/ COMPLIANCE CRITICAL CHARACTERISTICS SYMBOL
CPK		DENOTES CPK DIMENSIONS MINIMUM CPK VALUE
ST		DENOTES A CHARACTERISTIC THAT PROVIDES AN INDICATION OF PROCESS PERFORMANCE PROCEDURE FOR MEASUREMENT AND TRACKING TO BE DEFINED IN LITTELFUSE INSPECTION INSTRUCTIONS
CP		DENOTES CP DIMENSIONS, -MINIMUM CP VALUE MUST BE WITHIN THE DIMENSIONAL LIMITATIONS SHOWN ON DRAWING AND INITIALLY LOCATED TO ALLOW FOR MAXIMUM TOOL LIFE

DIMENSION: MM TOLERANCES UNLESS OTHERWISE SPECIFIED  
 ONE PLACE DECIMAL ± 0.5      THREE PLACES DECIMAL ± 0.100  
 TWO PLACES DECIMAL ± 0.20      ANGULAR ± 2°

	NAME	DATE
DRAWN	E MORALES	9/7/20
CHECKED	-	-
	-	-
	-	-

**Littelfuse**  
 Expertise Applied | Answers Delivered

FORM NO: CVP-PE40-0004 REV A  
 THIRD ANGLE PROJECTION

DO NOT SCALE DRAWING

**TITLE**  
 FUSEHOLDER MAXI-60A BOLT-ON TYPE

SIZE **B** DWG. NO. OL-01520001U REV. **A**  
 SCALE 1:1 SHEET 1 OF 1