

THIS DRAWING AND THE INFORMATION CONTAINED WITHIN IT ARE CONFIDENTIAL AND MAY NOT BE COPIED OR DISCLOSED WITHOUT THE WRITTEN PERMISSION OF LITTELFUSE.

REVISIONS				
ZONE	REV.	DESCRIPTION	DATE	APPROVED
	A	GCF#524592 INITIAL RELEASE	SEP./23/2021	D. ZHANG

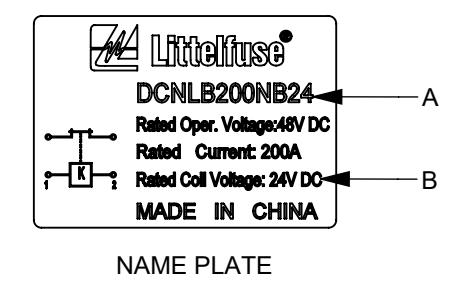

CIRCUIT SCHEMATIC DIAGRAM

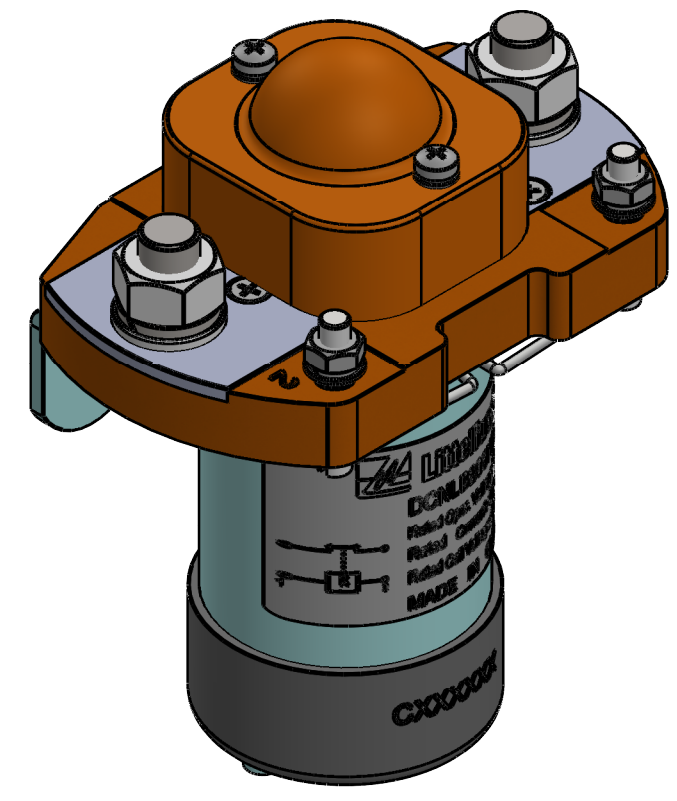
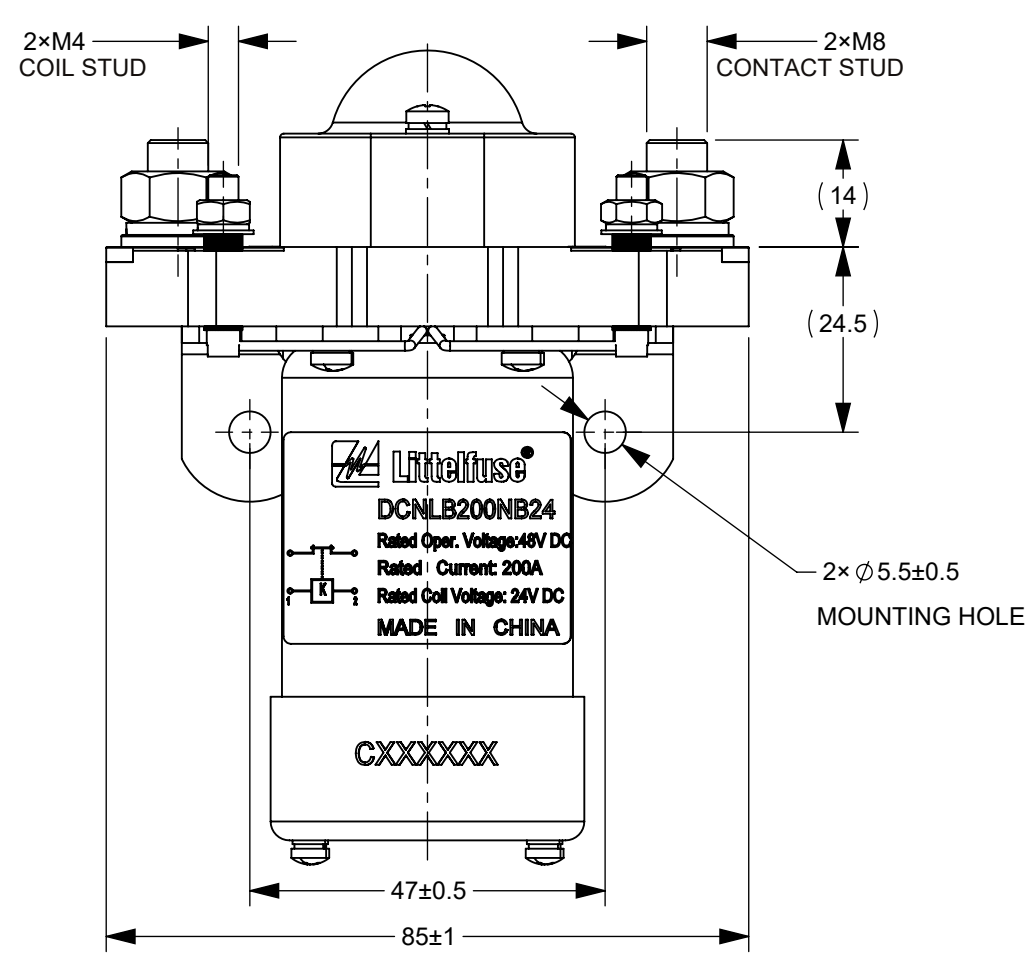
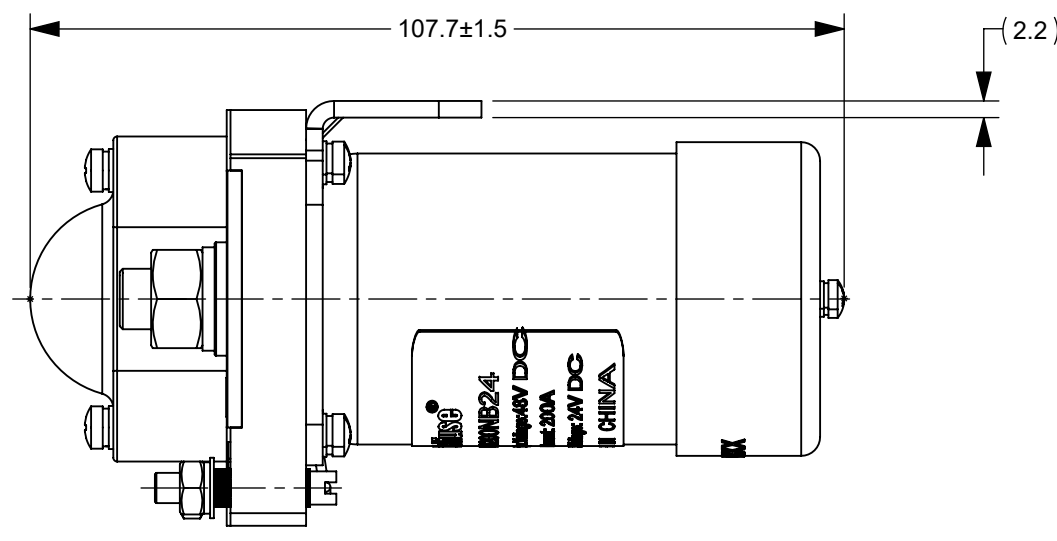
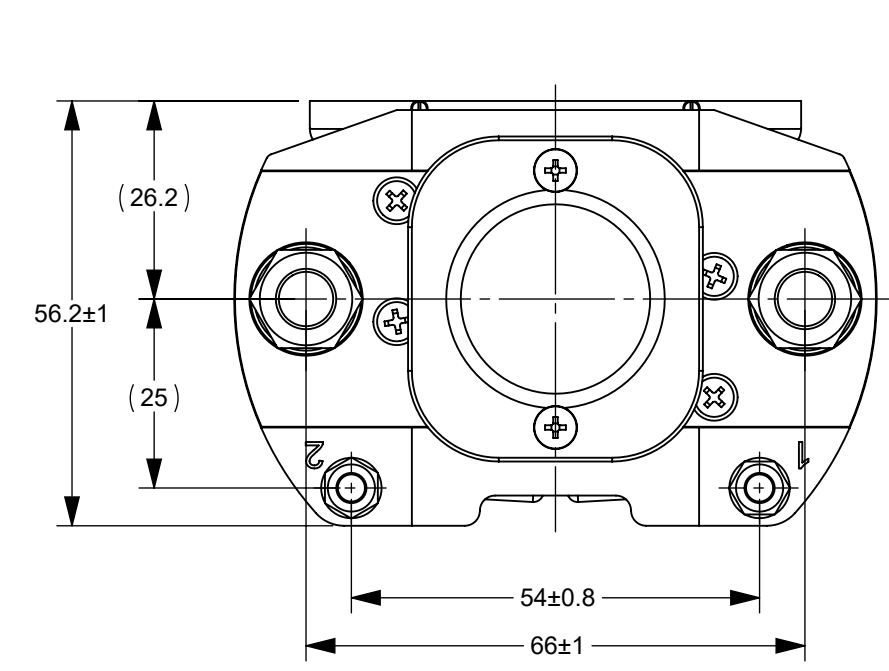
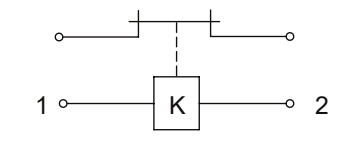

TABLE 1: TECHNICAL PARAMETERS

ITEM	PARAMETER	DCNLB200NB24 DCNLB200NB48 DCNLB200NB60		
HOLD POWER	START POWER	MAX 15W		
	MAINTAIN POWER	MAX 15W		
MAXIMUM CONTACT VOLTAGE		60V DC		
RATED CONTACT VOLTAGE		48V DC		
RATED CONTACT CURRENT		200A		
RATED COIL VOLTAGE		24V DC	48V DC	60V DC
OPERATING VOLTAGE IN COLD STATE @ (20±5)°C	PICKUP	17V DC MAX	34V DC MAX	42V DC MAX
	RELEASE	2V DC MIN	4V DC MIN	5V DC MIN
OPERATE TIME		MAX 50ms		
RELEASE TIME		MAX 50ms		
BOUNCE TIME		MAX 12ms		
CONTACT VOLTAGE DROP		≤50mV@100 A		
LIMIT BREAKING ABILITY		4le/5ms, 1CYCLES		
DIELECTRIC STRENGTH		1000V AC, 50Hz, 1min., LEAKAGE CURRENT ≤1 mA		
INSULATION RESISTANCE		≥50MΩ@500VDC		
ELECTRIC LIFE		3000 CYCLES		
MECHANICAL LIFE		100,000 CYCLES		
WORKING DUTY		CONTINUOUS		

TABLE 2 OPERATING VOLTAGE PARAMETER

NO.	PN	NAME PLATE		REMARK
		"A" OF NAME PLATE	"B" OF NAME PLATE	
1	DCNLB200NB24	DCNLB200NB24	Rated Coil Voltage: 24V DC	
2	DCNLB200NB48	DCNLB200NB48	Rated Coil Voltage: 48V DC	
3	DCNLB200NB60	DCNLB200NB60	Rated Coil Voltage: 60V DC	

NOTES:

- ALL SIZES ARE FOR REFERENCE ONLY.
- SEE TABLE 2 FOR CONFIGURATION OF NAME PLATE, OPERATING VOLTAGE AND PNs.
- MATERIALS AND FINISHING:
  - BASE: THERMOSETTING PLASTIC, UL94V-0.
  - CONTACTS: SILVER ALLOY.
  - COIL STUD: COPPER ALLY, SILVER PLATED.
- PRODUCT TECHNICAL PARAMETERS: SEE TABLE 1.
  - CONTACT ARRANGEMENT: SPST-NC.
  - CONNECTION STUD: M8 STUD, RECOMMENDED TORQUE 9 N•m ~ 11 N•m; M4 STUD, RECOMMENDED TORQUE 1.7 N•m ~ 2.5 N•m.
  - MOUNTING: M5 BOLT, RECOMMENDED TORQUE 4 N•m ~ 5 N•m.

DIMENSIONS ARE SHOWN IN MILLIMETERS. DIMENSIONS AND TOLERANCES ARE DEFINED ACCORDING TO ANSI/ASME Y14.5-1994.

PER CHNFPD20-008 PROCEDURE

- FIT/ FUNCTION CRITICAL CHARACTERISTICS
- <S> SAFETY/ COMPLIANCE CRITICAL CHARACTERISTICS SYMBOL
- CPK DENOTES CPK DIMENSIONS MINIMUM CPK VALUE
- (ST) DENOTES A CHARACTERISTIC THAT PROVIDES AN INDICATION OF PROCESS PERFORMANCE PROCEDURE FOR MEASUREMENT AND TRACKING TO BE DEFINED IN LITTELFUSE INSPECTION INSTRUCTIONS
- CP DENOTES CP DIMENSIONS. MINIMUM CP VALUE MUST BE WITHIN THE DIMENSIONAL LIMITATIONS SHOWN ON DRAWING AND INITIALLY LOCATED TO ALLOW FOR MAXIMUM TOOL LIFE

DRAWN	JY. SHI	SEP./8/2021
CHECKED	J. LI	SEP./15/2021

**Littelfuse**  
Expertise Applied | Answers Delivered

FORM NO. CVP-PE40-0005 REV B  
THIRD ANGLE PROJECTION

TITLE: DCNLB 200A 48V CONTACTOR

DO NOT SCALE DRAWING

SCALE 1:1

SHEET 1 OF 1