

MOUNTING SPECS:

RECOMMENDED FASTENER: M10 OR 3/8"
TIGHTENING TORQUE (REFERENCE ONLY): 26Nm

REVISION		
REV	DATE	DESCRIPTION
A	3/13/20	522085GCP - RELEASE MRY
B	3/23/20	522118ECP/D - UPDATE LENGTH MRY
C	10/25/23	526838ECP/D - ADD VIEW W/O MICROSWITCH MRY

FUSE WITH MICROSWITCH

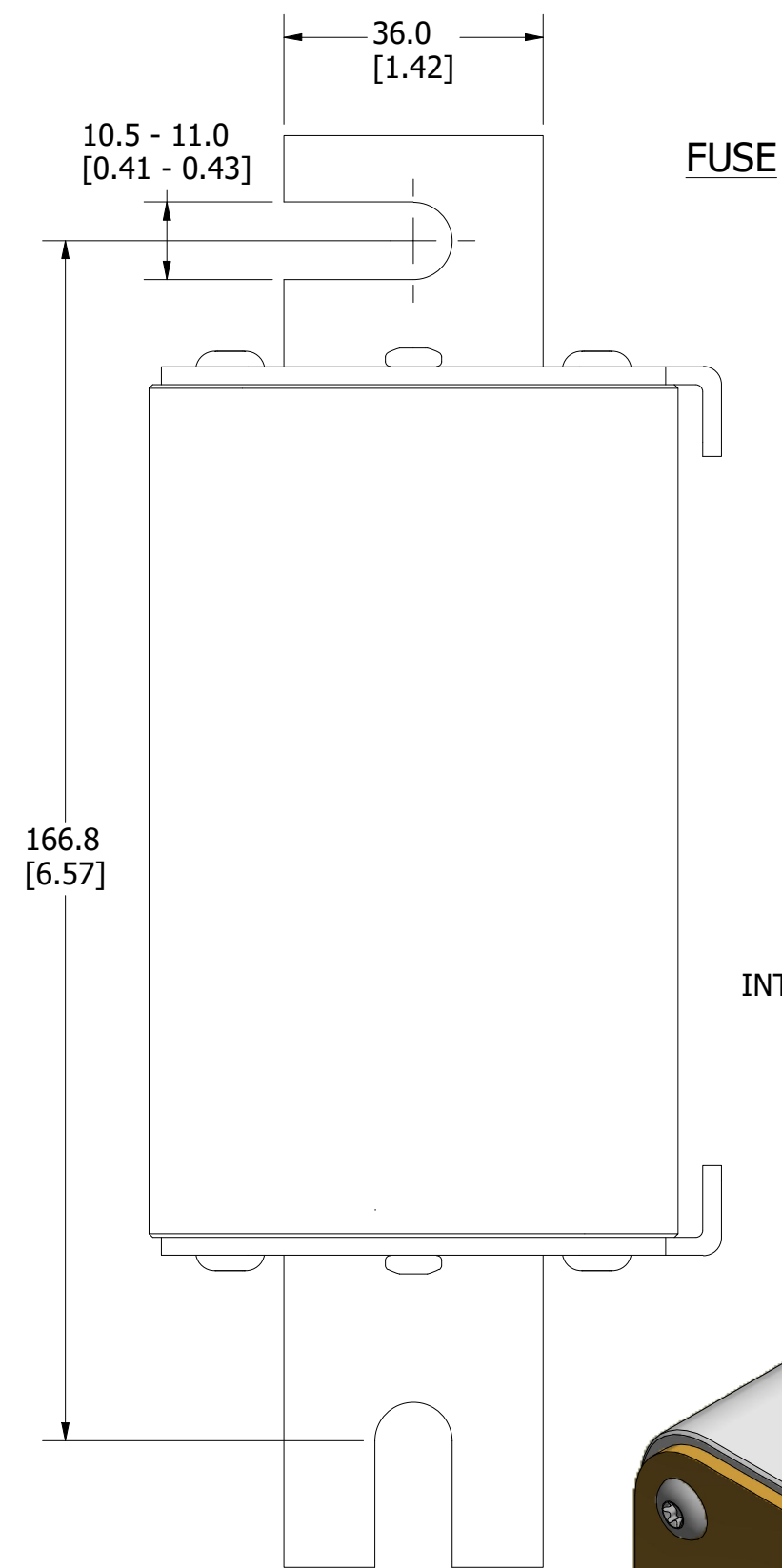
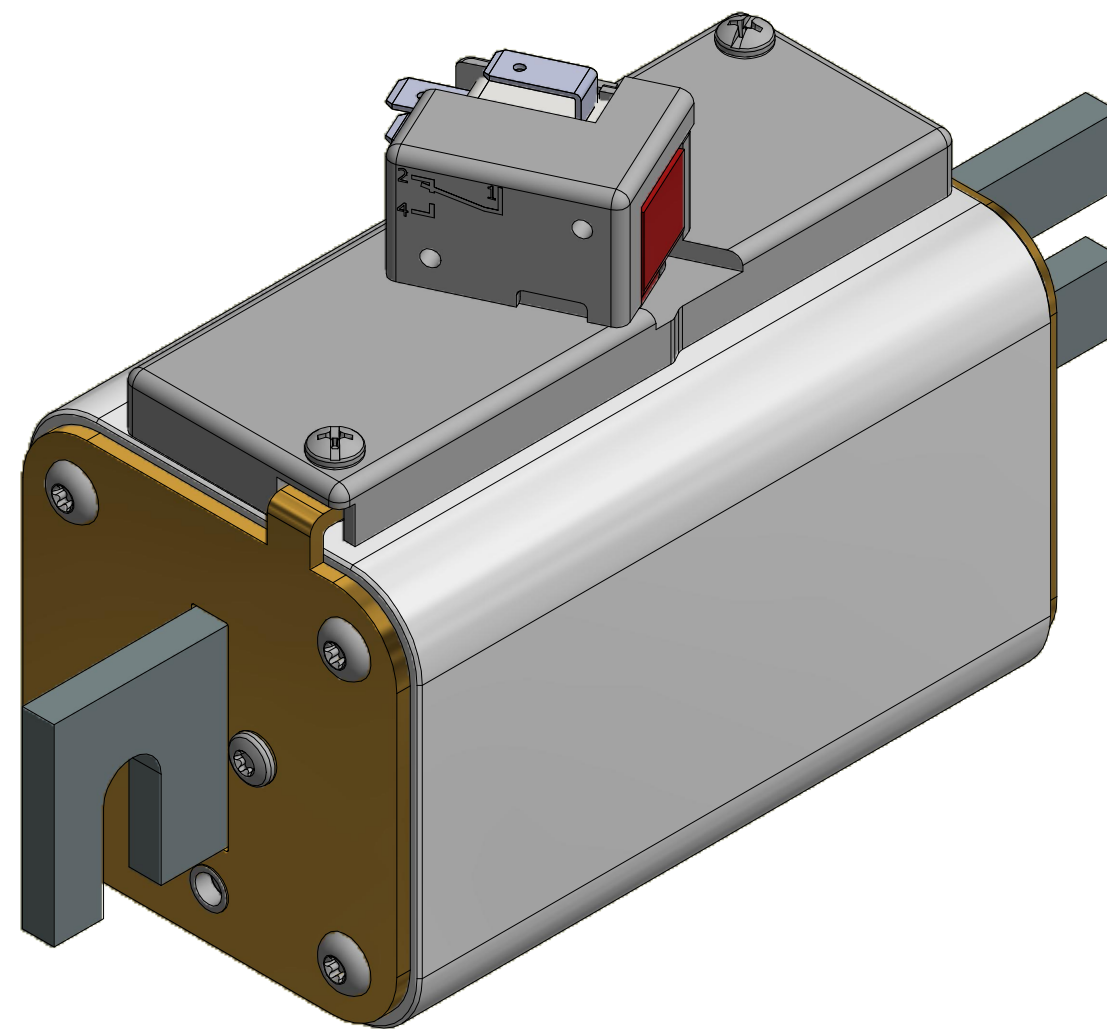
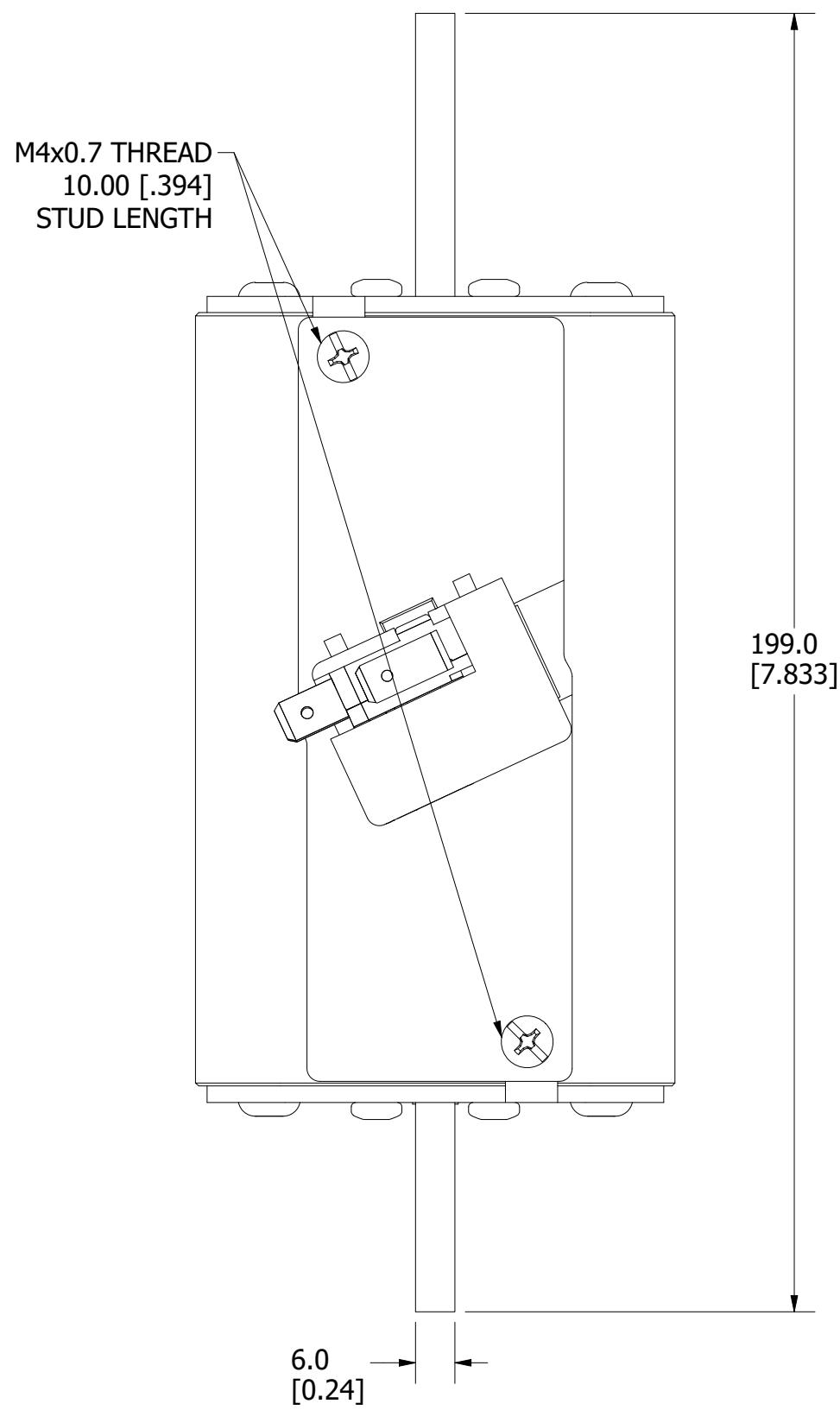

FUSE

INTERNAL INDICATOR

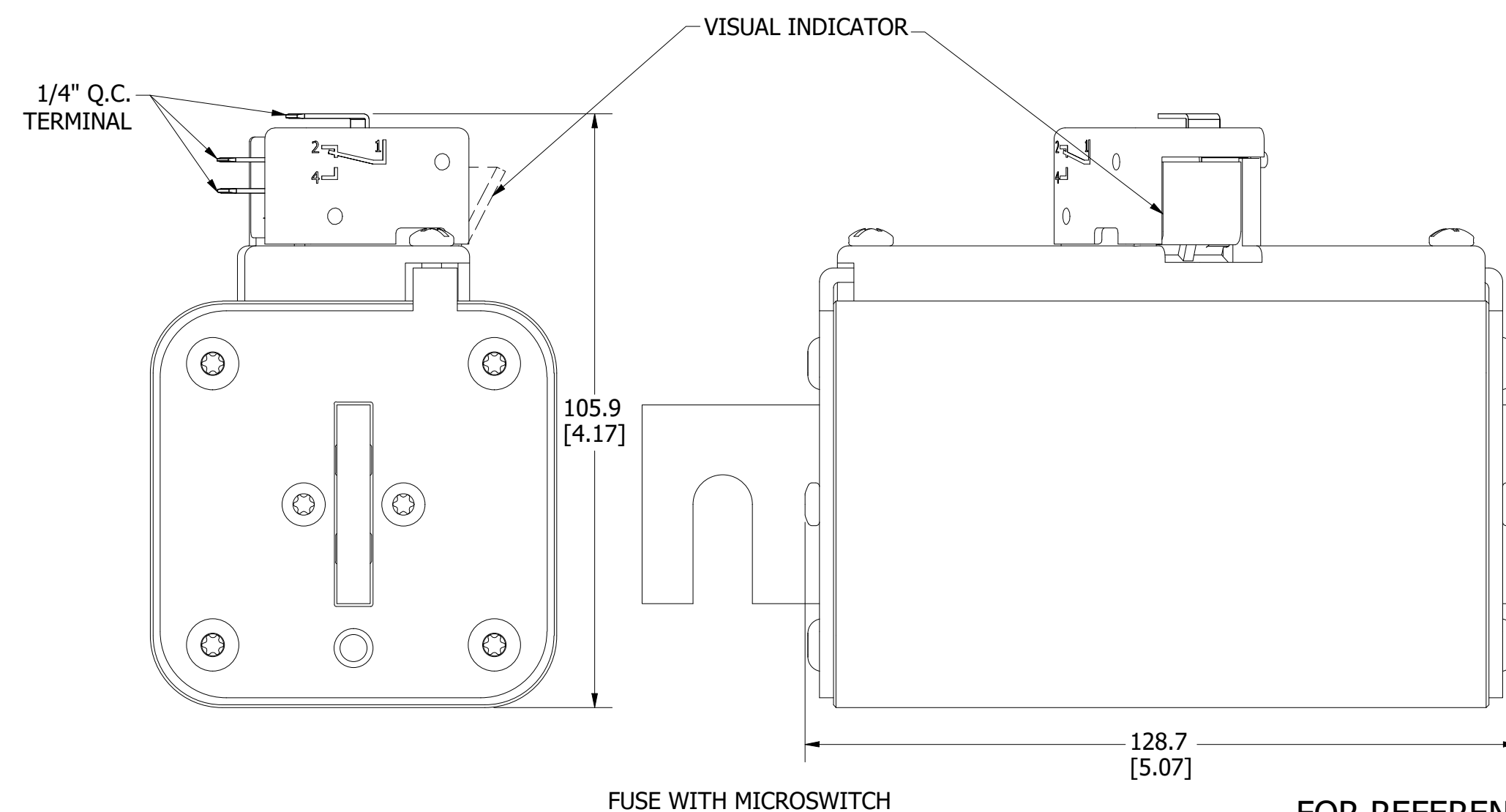
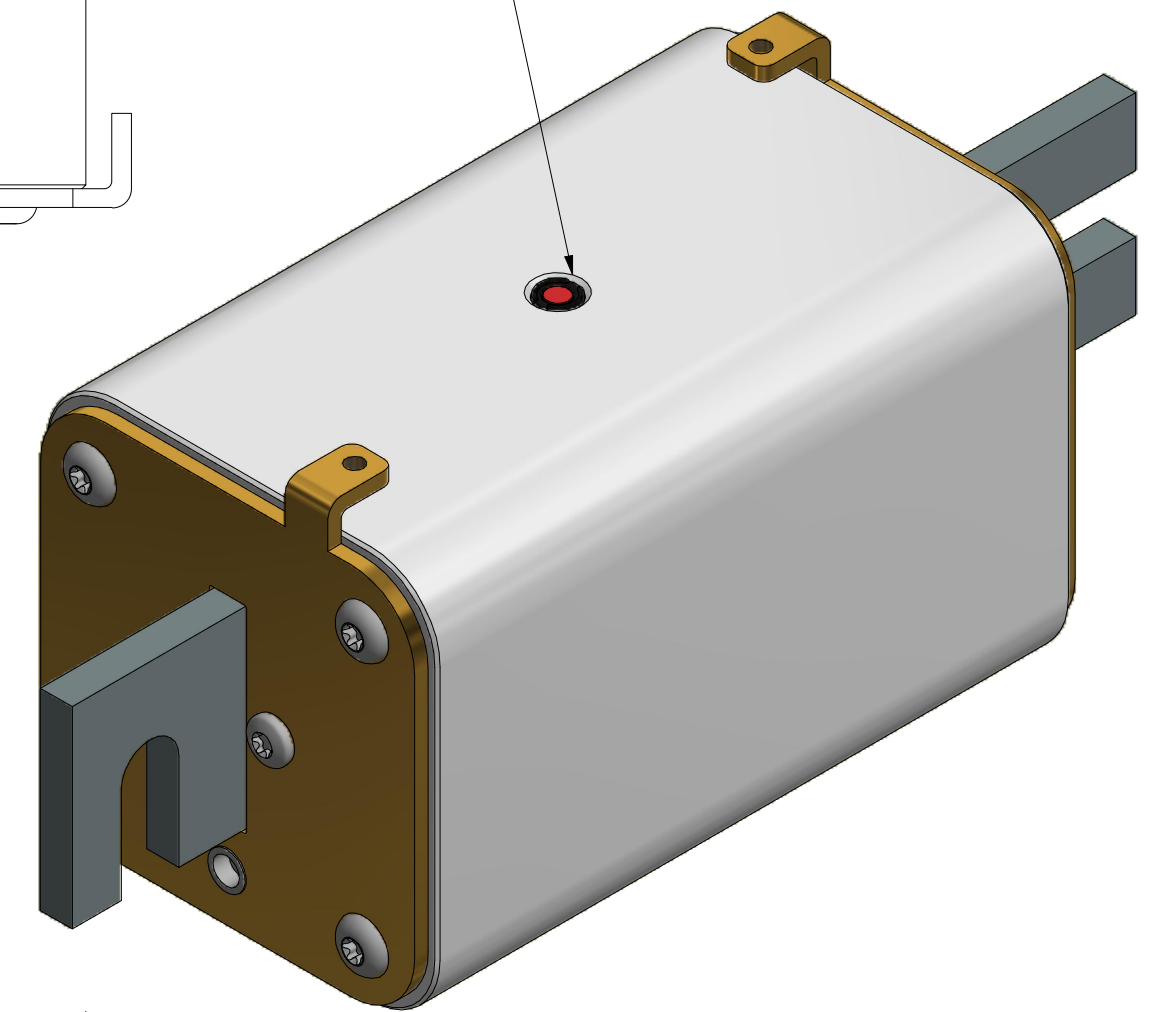

FUSE WITH MICROSWITCH

FOR REFERENCE ONLY

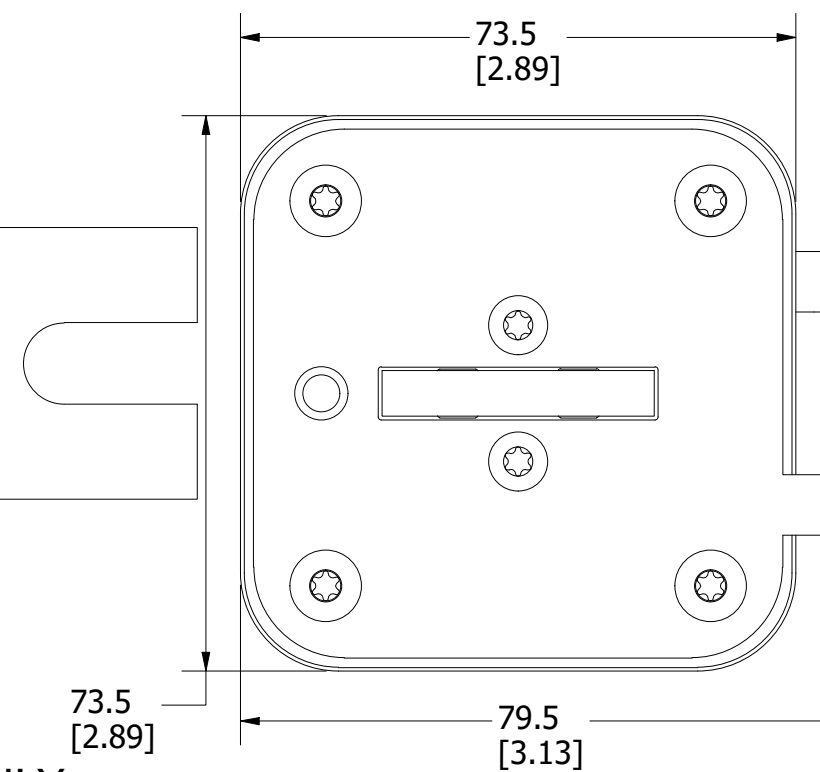

<S>	CRITICAL CHARACTERISTIC FOR PART SAFETY/COMPLIANCE
●	DENOTES CRITICAL CHARACTERISTICS.
CPK	DENOTES CPK DIMENSIONS, -MINIMUM CPK VALUE
ST	DENOTES A CHARACTERISTIC THAT PROVIDES AN INDICATION OF PROCESS PERFORMANCE. PROCEDURE FOR MEASUREMENT AND TRACKING TO BE DEFINED IN LITTELFUSE INSPECTION INSTRUCTIONS.
CP	DENOTES CP DIMENSIONS, -MINIMUM CP VALUE MUST BE WITHIN THE DIMENSIONAL LIMITATIONS SHOWN ON DRAWING AND INITIALLY LOCATED TO ALLOW FOR MAXIMUM TOOL LIFE.

MATL SPEC	FINISH
DRW myork	DATE 3/9/2020
SCALE NTS	FINISH GOOD WT GRAMS/PIECE

UNLESS OTHERWISE SPECIFIED, DIMENSIONS ARE IN MILLIMETERS, DIMENSIONS IN BRACKETS [] ARE INCHES DIMENSIONING AND DO NOT INCLUDE PLATING. TOLERANCING TO BE INTERPRETED IN ACCORDANCE WITH ANSI Y14.5M-1994

3RD ANGLE PROJECTION	
----------------------	--

TITLE PSX SIZE 3XL DIN (DB) FUSE OUTLINE

Littelfuse CHICAGO, ILLINOIS 60631	REVISION C	DRWG NO. OL-PSX3XLD000	SHEET 1 OF 1
--	------------	------------------------	--------------