

REVISION		
REV	DATE	DESCRIPTION
A	12/28/20	523247GCP - RELEASE MRY

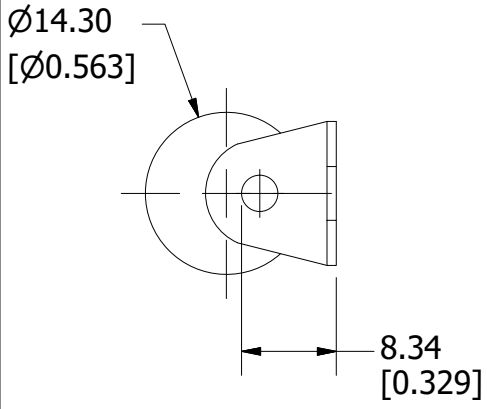
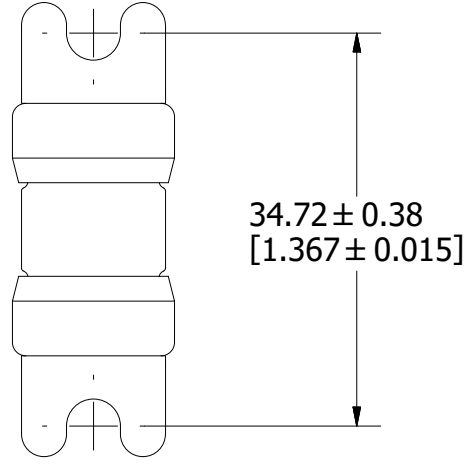
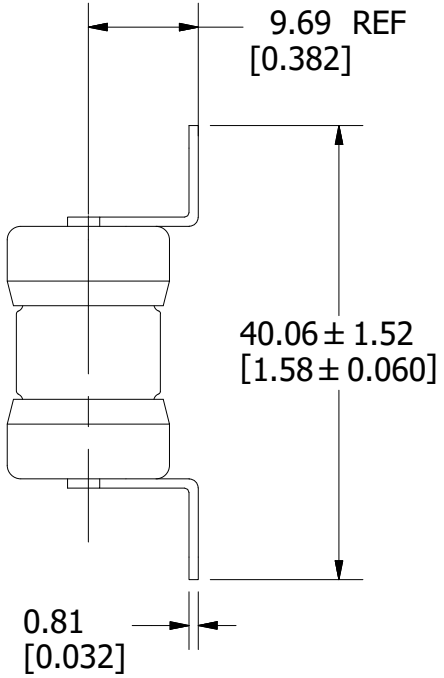

<S>	CRITICAL CHARACTERISTIC FOR PART SAFETY/COMPLIANCE
●	DENOTES CRITICAL CHARACTERISTICS.
CPK	DENOTES CPK DIMENSIONS, -MINIMUM CPK VALUE
ST	DENOTES A CHARACTERISTIC THAT PROVIDES AN INDICATION OF PROCESS PERFORMANCE. PROCEDURE FOR MEASUREMENT AND TRACKING TO BE DEFINED IN LITTELFUSE INSPECTION INSTRUCTIONS.
CP	DENOTES CP DIMENSIONS, -MINIMUM CP VALUE MUST BE WITHIN THE DIMENSIONAL LIMITATIONS SHOWN ON DRAWING AND INITIALLY LOCATED TO ALLOW FOR MAXIMUM TOOL LIFE.

A

MATL SPEC		FINISH	
DRW myork	DATE 12/28/2020	SCALE NTS	FINISH GOOD WT GRAMS/PIECE

UNLESS OTHERWISE SPECIFIED, DIMENSIONS ARE IN MILLIMETERS, DIMENSIONS IN BRACKETS [] ARE INCHES DIMENSIONING AND DO NOT INCLUDE PLATING. TOLERANCING TO BE INTERPRETED IN ACCORDANCE WITH ANSI Y14.5M-1994

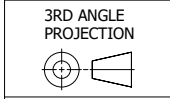

TITLE	TLS-LB SERIES OUTLINE
--------------	-----------------------

NOTES:
 RECOMMENDED HARDWARE: #8 SLOTTED HEX WASHER HEAD MACHINE SCREW
 TORQUE: 10 IN-LB

 CHICAGO, ILLINOIS 60631	REVISION	DRWG NO.	SHEET 1 OF 1
	A	OL-0TLS000LB	OUTLINE