

Technical Information

Glossary

AT - Abbreviation for Ampere-Turns

This is the unit of measure used to define the sensitivity of a switch. It is the product of the number of turns of the coil the switch is tested in and the current in Amperes flowing in that coil. Example: using a standard L4989 test coil with 5,000 turns; a current of 10mA will generate 50 AT (5,000 x 0.010).

Arc Suppression

Contact protection circuitry used to protect the contacts of reed switches against loads which produce high inrush currents on closure or high voltages on opening.

Bounce

When closing, the contacts of a reed switch will initially bounce or chatter before reaching a stable closed state. This could be seen as multiple inputs to certain logic or digital circuits. If contact bounce is detrimental to your circuit design, a debounce circuit should be used. Right is a sample of a typical debounce circuit. Please contact Littelfuse for recommended component values.

Capacitive Loads

Loads which consist of a capacitor either in series or in parallel with the contacts of a reed switch. There is a high capacitive current when the switch contacts close. Without any current limiting device, the peak current can reach up to tens of amps. Use one of the following, or similar contact protection circuits when using a reed switch with capacitive loads.es.

Coaxial Shield

Used for switching high frequency signals, the coaxial shield normally consisting of copper is found inside the coil of a reed relay.

Coil Resistance

The resistance in ohms of a reed relay coil.es.

Coil Voltage

The nominal coil voltage is the normal operating voltage of a reed relay. The must operate voltage is the voltage needed to change a relay from its inactive to active state. The must release voltage is the minimum voltage at which a relay will change from its active to inactive state. The maximum coil voltage should never be exceeded.

Contact Form

The inactive state of the contacts of a reed switch. Form A: Single Pole Single Throw Normally Open (SPST NO). Form B: Single Pole Single Throw Normally Closed (SPST NC). Form C: Single Pole Double Throw Change Over (SPDT CO)

Contact Resistance

The initial closed contact resistance in ohms.es.

Current Carry

The continuous current that the reed switch can carry while closed at 125% of the Pull-In value. Current, Inrush: The high current upon closure caused by the low resistance of a cold filament in a lamp load, by a reverse-magnetised core in an AC inductive load, or by a capacitive load.es.

Current, Switching

The maximum amount of current that the contacts of a reed switch can withstand on opening or closure.

DO - Abbreviation for Drop-Out

The value in Ampere-Turns at which the switch contacts just release.

Diode Suppression

An internal diode in parallel with the reed relay coil used to protect the circuitry powering the relay from the voltage spike generated from the coil when it is deactivated.

Electrostatic Shield

Used to reduce any noise or electrostatic coupling that may occur between the coil of a relay and the internal magnetic reed switch. The electrostatic shield normally consists of copper, terminated to a designated pin externally connected to ground.

Hermetically Sealed

The contacts of a reed switch along with an inert gas are sealed inside of a glass capsule. A glass to metal seal is used to provide the lowest rate of gas leakage possible.es.

Inductive Loads

Loads which consist of an inductive component such as the coil from an electromagnetic counter, relay, or solenoid. The inductance of the coil stores energy which results in a high arc voltage as the contacts of the reed relay open. Depending on the value of the inductance, the voltage induced by the coil can be upwards of several hundred volts. Use one of the following, or similar contact protection circuits when using a reed switch with an inductive load. The use of varistors is generally not recommended due to their high capacitance.

Figure 1
Inductive Loads

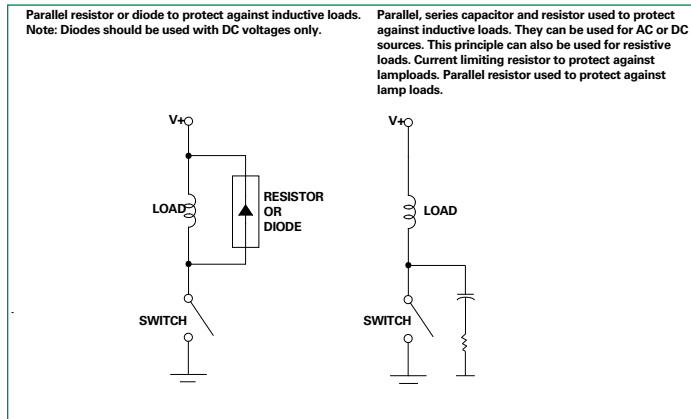

Insulation Resistance

The resistance in ohms measured across the open contacts of a reed switch or relay or between the isolated terminals of a reed relay.

Lamp Loads

Loads which consist of a lamp containing a tungsten or similar type of filament. The filament will have a high inrush current due to its initial low resistance when cold. Use one of the following, or similar contact protection circuits when using a reed switch with a lamp load.

Figure 2
Lamp Loads

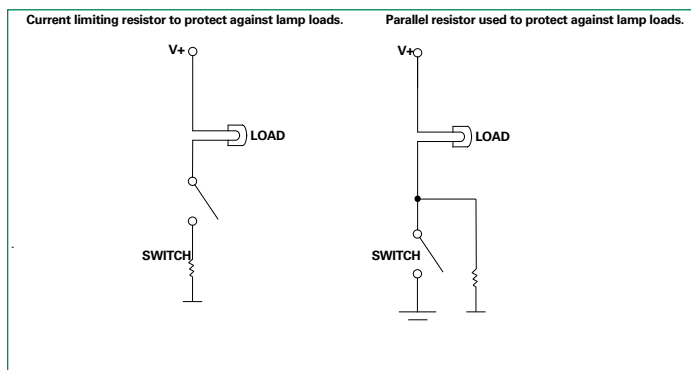

Magnetic Shield

An external metal housing of a reed relay used to protect either the internal magnetic reed switch from external magnetic influences, or to protect any external neighbouring components from the magnetic influences of the relay.

Operating Time

The amount of time (including bounce) measured from the point at which the coil of an inactive relay is energised to the point at which the contacts of the relay arrive at their active state. For a reed switch, this is measured using a standard coil energised to 150% of the Pull-In value.

Operating Temperature

The maximum or minimum temperature at which a device can be operated without significant performance degradation.

Littelfuse, Inc.
8755 West Higgins Road, Suite 500
Chicago, IL 60631 USA
Phone: (773) 628-1000
Littelfuse.com