

The SDP0240T023G6 SIDACTor® Protection Thyristor is engineered for tertiary overvoltage protection in applications such as the VDSL2, ADSL2, and ADSL2+ cards commonly used in broadband communications. This robust, solid-state component provides a surge capability of 30A (based on the IEC 61000-4-5 1.2/50–8/20µs waveform) in a compact, surface-mount SOT23-6 (see Figure 3) package; most components of similar size offer far less surge handling capabilities.



Because it is designed to have minimal impact on data signaling, the SDP0240T023G6 will not negatively impact the application's rate or reach. This component was created using a new silicon process (patent pending) that provides a high-speed crowbar response to surges, ensuring lower overshoot voltages and improved ESD, lightning, and power fault protection. This process also ensures the component's low off-state capacitance will vary less than 1pF over the range from 0V to its standoff voltage without external biasing (see Figure 1).

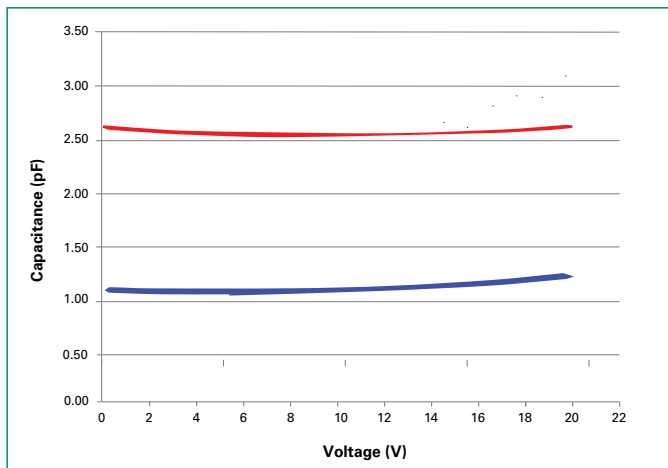

Figure 1. Non-biased capacitance variance vs. line voltage chart (red line is longitudinal values/blue line is differential values)

The relatively flat curves shown in **Figure 1** demonstrate the SDP0240T023G6's minimal variation in capacitance as the line voltage approaches the standoff voltage. The red curve indicates the longitudinal (from each line to the ground reference of the chipset) capacitance values; the blue curve shows the differential (or transverse) values. The results shown were obtained without the application of an external bias. However, if a biasing voltage is included, it will restrain the off-state capacitance changes to nearly zero.

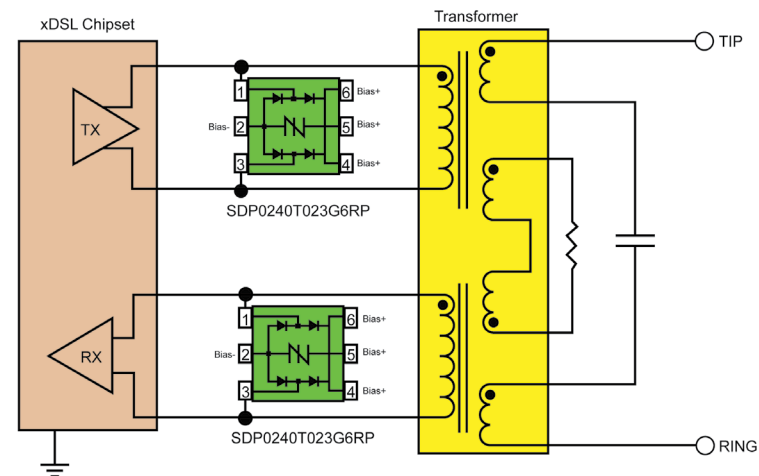

Figure 2. The SDP0240T023G6 is placed between the line driver and coupling transformer, so the transformer and any line side component will provide the initial overvoltage protection mitigation.

The SDP0240T023G6 shown in **Figure 2** is optimized for overvoltage protection of xDSL line drivers. It is intended for installation between the line driver and the coupling transformer, so the transformer and any line side component used will provide the initial overvoltage protection/surge mitigation. The SDP0240T023G6 component can handle any residual lightning, ESD or power fault surge content that does get coupled across the transformer isolation barrier. If the SDP0240T023G6's "Bias-" pin (Pin 2) is connected to the xDSL chipset's ground reference, it can provide both common mode and differential mode protection. If its "Bias+" and "Bias-" pins are connected to the DSL chipset's ± voltage rails (must be ≤ 19V), it can provide rail-to-rail protection for any surges >19–29V (the component's VDRM to VS range).



Figure 3. SDP Biased Series SOT 23-6 from Littelfuse

The SDP0240T023G6 provides a perfectly balanced broadband protection solution because it will not convert a longitudinal surge event into a differential event. This UL Recognized Component (file number E133083) is compatible with DSL bandplans up to and including the 30a bandplan (30 MHz) with turn-on response times of less than 500ns. Its off-state voltage of 19V with <100nA of leakage current makes it a good choice for use with Class H DSL line drivers, where the boosted supply voltage can force the DMT peaks up to +19V or as low as -5V.

For more information on this product, including detailed specs, surge ratings, packing options, etc., [consult the datasheet available](#) on the Littelfuse website.

Littelfuse, Inc.

8755 West Higgins Road, Suite 500
Chicago, IL 60631 USA
Phone: (773) 628-1000
Littelfuse.com

Please call the factory for further information.
Application Note: xDSL SDP0240T023G6
Protection
August 2013
SIDACtor[®] is a registered trademark.