

## Using High Voltage TVS Diodes in IGBT Active Clamp Applications

Insulated Gate Bipolar Transistors (IGBTs) are widely used in power inverters, industrial drives, electric vehicle chargers, motor control, and induction heating in home appliances because of their ease of use and their high voltage and current driving capabilities. Today, power semiconductor manufacturers are offering IGBT modules with ever-higher power densities. The power density limit is determined by the maximum power loss that can be dissipated; optimization criteria are the packaging technology, as well as the conduction and switching losses of the semiconductor chips. The high current density of the modules, together with high switching speeds, place greater demands on the driving circuits, both in normal switching operation and under overload conditions. Active clamping switching technology offers a solution that illustrates how modern, high power IGBTs can be used with high reliability, especially in high speed railway and automotive traction applications.

### Analysis of overvoltage during IGBT turn-off

IGBT modules and converter circuits have parasitic inductances that can't be completely eliminated; their influence on system behavior also can't be ignored. Figure 1 illustrates the parasitic inductances contained in a commutation circuit. The current change caused by turning off the IGBT produces an overshoot voltage at its collector terminal, as shown in Figure 2.

The commutation speed (and therefore, the turn-off overvoltage) at an IGBT can, in principle, be affected by the turn-off gate resistance  $R_{g(off)}$ . This technique is used particularly at lower power levels. However, the  $R_{g(off)}$  must then be matched for overload conditions, such as turn-off of the double-rated current, short circuit, and a temporarily increased link circuit voltage. In normal operation, this results in increased switching losses and turn-off delays, which reduces the usability or efficiency of the modules. As a result, this simple technique is unsuitable for modern high power modules.

Figure 1. Parasitic inductance

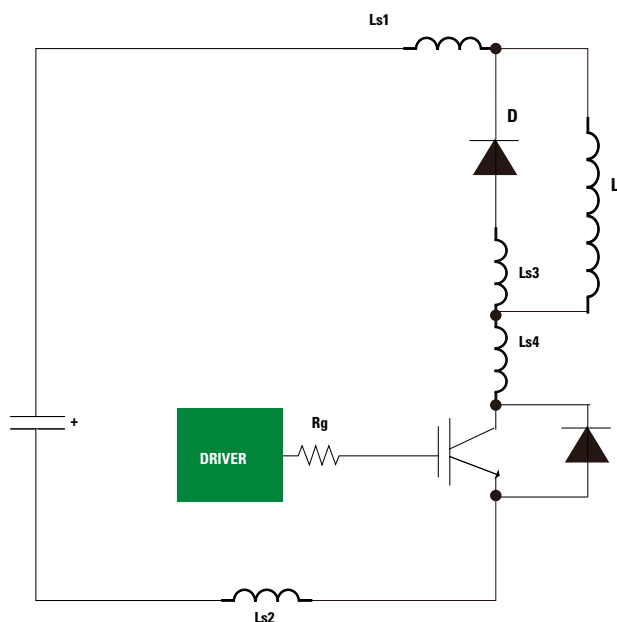
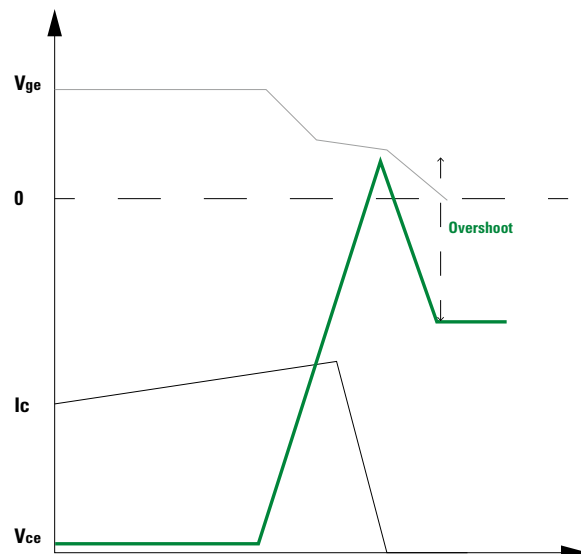

Figure 2. IGBT shut-off overshoot



## Soft turn-off

The problems described in the previous paragraph have led to the development of two-stage turn-off, soft-switch-off, and slow turn-off driver circuits operating with a reversible gate resistance. In normal operation, a low ohmic gate resistor is used to turn the IGBT off in order to minimize the switching losses; a high ohmic one is used when a short circuit or surge current is detected (see Figure 3). However, the problem lies in detecting these conditions reliably: desaturation monitoring always involves a delay until a fault is detected (typically 4-10  $\mu\text{s}$ ) known as the response time. When IGBTs are driven with a pulse that is shorter than the response time in the event of a short circuit, the fault is not detected and the driver turns off too quickly. The resulting overvoltage destroys the IGBT. Moreover, coverage of limit cases (between overcurrent/non-overcurrent) presents a problem; for instance, a higher overvoltage may well occur when the double-rated current is turned off than at a short-circuit turn-off.

These kinds of driver circuits must be considered dangerous; users should be advised not to use them in higher power equipment and in systems from which high reliability is expected.

## Active clamp

Active clamping is traditionally used only to protect the semiconductor in the event of a transient overload. Consequently, the clamping elements are never subjected to recurrent pulse operation. The problem of repetitive operation is limited by the IGBT and driver power; during active clamping, both the IGBT and the driver will absorb energy. Active clamping means the direct feedback of the collector potential to the gate via an element with an avalanche characteristic. Figure 4 illustrates this principle using an IGBT switch.

**Figure 3. Soft turn-off**

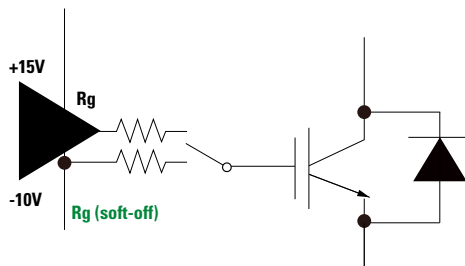

**Figure 4. Active clamp topology**

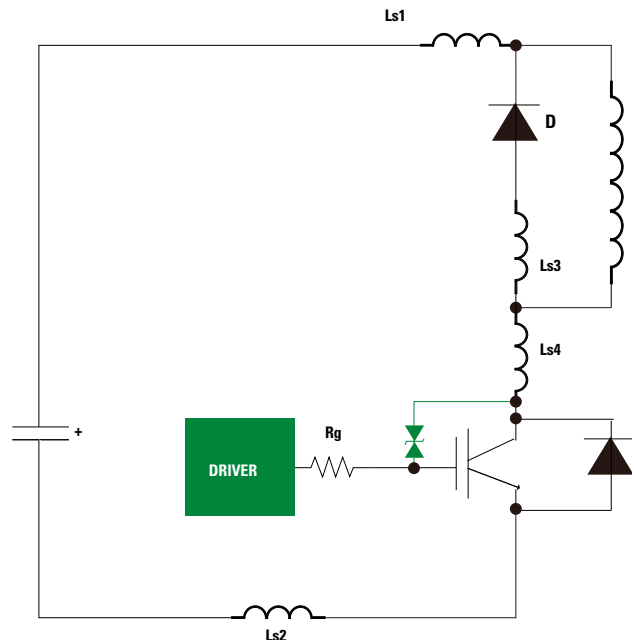

The feedback branch consists of a clamping element, which, as a rule, is made up of a series of transient voltage suppression (TVS) diodes. If the collector-emitter voltage exceeds the approximate breakdown voltage of the clamping element, a current flows via the feedback to the gate of the IGBT, raising its potential, so that the rate of change of the collector current is reduced, producing a stable condition. The voltage across the IGBT is then determined by the design of the clamping element. The IGBT operates in the active range of its output characteristic and converts the energy stored in the stray inductance into IGBT heat. The clamping process continues until the stray inductances have been demagnetized. The fundamental relationships involved here on the basis of typical curves are illustrated in the lower part of Figure 5.

A single high voltage TVS diode, or several lower voltage TVS diodes connected in series with a resultant high voltage, can be used to provide active clamping based on the DC power line voltage or IGBT Vce voltage.

**Figure 5. Active clamp waveform**

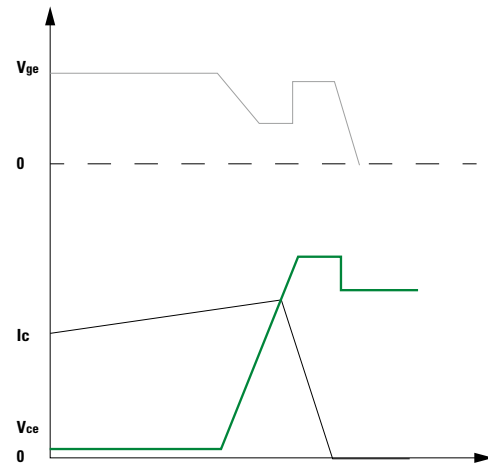

Table 1 showed the Littelfuse TVS TPSMB series with standoff voltage from 150V to 650V, these cover a wide range of voltage options for working with different voltage and power of IGBTs. Depending on protection requirements, in some cases, 2 to 3 TVS diode can be connected in-series to form a higher voltage TVS and this string TVS diodes help share each TVS voltage for better electrical creepage and power handling. With detail selection, please see below demo board and its test data.

**Table 1. Littelfuse TVS diode part numbers can be used in IGBT Active clamping protection**

Part Number (Uni)	Part Number (Bi)	Typical IR @ 150°C (µA)	Reverse Stand off Voltage VR (Volts)	Breakdown Voltage VBR (Volts) @ IT		Test Current IT (mA)	Maximum Clamping Voltage VC @ Ipp (V)	Maximum Peak Pulse Current Ipp (A)	Maximum Reverse Leakage IR @ VR (µA)	Maximum Temperature coefficient of VBR (%/C)	UL Agency Approval
				Max.	Min.						
TPSMB150A	TPSMB150CA	8	128.00	143.00	158.00	1	207.0	2.9	1	0.108	X
TPSMB160A	TPSMB160CA	8	136.00	152.00	168.00	1	219.0	2.8	1	0.108	X
TPSMB170A	TPSMB170CA	8	145.00	162.00	179.00	1	234.0	2.6	1	0.108	X
TPSMB180A	TPSMB180CA	8	154.00	171.00	189.00	1	246.0	2.5	1	0.108	X
TPSMB200A	TPSMB200CA	8	171.00	190.00	210.00	1	274.0	2.2	1	0.108	X
TPSMB210A	TPSMB210CA	8	179.60	199.50	220.50	1	288.0	2.1	1	0.110	-
TPSMB220A	TPSMB220CA	8	185.00	209.00	231.00	1	328.0	1.9	1	0.110	X
TPSMB250A	TPSMB250CA	8	214.00	237.00	263.00	1	344.0	1.8	1	0.110	X
TPSMB300A-A	TPSMB300CA-A	8	256.00	285.00	315.00	1	414.0	1.5	1	0.110	X
TPSMB350A-A	TPSMB350CA-A	8	300.00	332.00	368.00	1	482.0	1.3	1	0.112	-
TPSMB400A-A	TPSMB400CA-A	8	342.00	380.00	420.00	1	548.0	1.1	1	0.112	-
TPSMB440A-A	TPSMB440CA-A	8	376.00	418.00	462.00	1	602.0	1.0	1	0.112	-
TPSMB480A-A	TPSMB480CA-A	8	408.00	456.00	504.00	1	658.0	0.9	1	0.112	-
TPSMB510A-A	TPSMB510CA-A	8	434.00	485.00	535.00	1	698.0	0.9	1	0.112	-
TPSMB520A-A	TPSMB520CA-A	8	443.00	494.50	545.50	1	718.0	0.9	1	0.112	-
TPSMB530A-A	TPSMB530CA-A	8	451.00	503.50	556.50	1	725.0	0.8	1	0.112	-
TPSMB540A-A	TPSMB540CA-A	8	460.00	513.00	567.00	1	740.0	0.8	1	0.112	-
TPSMB550A-A	TPSMB550CA-A	8	468.00	522.50	577.50	1	760.0	0.8	1	0.112	-
-	TPSMB600CA-A	8	511.00	570.00	630.00	1	828.0	0.8	1	0.112	-
-	TPSMB650CA-A	8	553.00	617.50	682.50	1	897.0	0.8	1	0.112	-

## Detail Test for Active Clamp

Littelfuse has developed an active clamp test evaluation board to help users better understand how the active clamp operates.

The TD352 outlined in Figure 6 is an IGBT gate driver IC, which provides driving signal to the MG12100S-BN2MM IGBT, a Littelfuse IGBT module. The TPSMB600CA-A is an automotive-grade TVS diode with 600W peak pulse power (@10/1000) and a breakdown voltage of 600 V. This evaluation board offers users the flexibility to test an IGBT in a discrete package like the TO-247 or a module type with the connection from the Q2 copper trace.

**Figure 6. Active clamp evaluation board circuit topology**

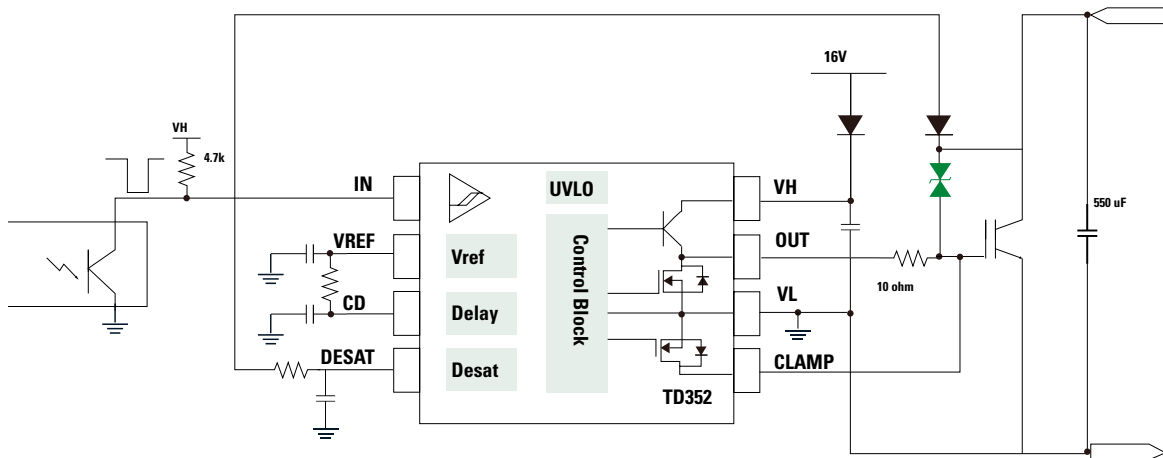

Part	Specification	Vbr@1mA	Vc@active clamp
IGBT	1200 V 140 A, MG12100S-BN2MM	/	/
TVS	TPSMB600CA-A	606 V	656 V

**Figure 7. Active clamp demo layout and function**

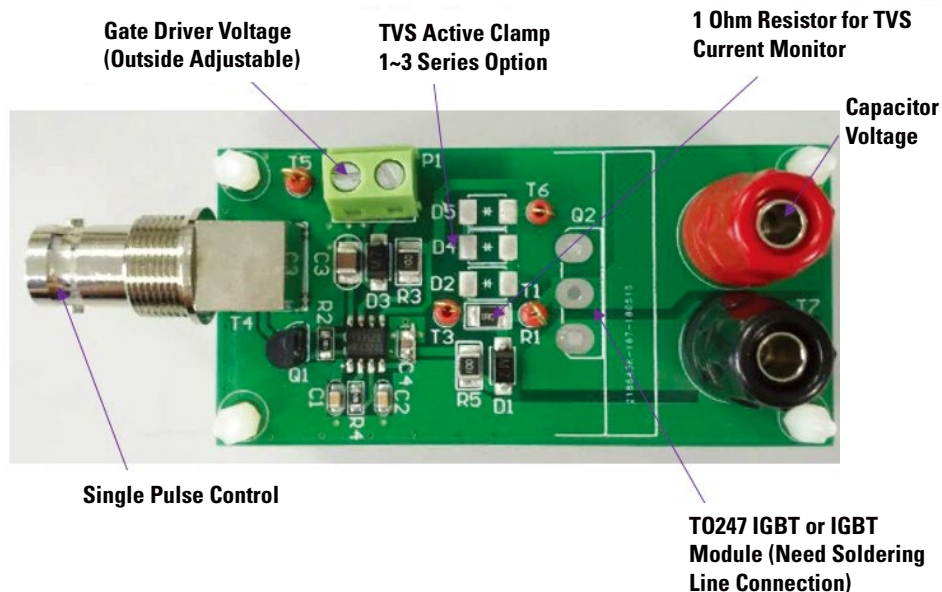

**Figure 8. Actual active clamp with TPSMB600CA-A and DC voltage of 500 V**



Blue: TVS Voltage  
Green: Vge Voltage  
Pink: TVS Current  
Yellow: Short Ice

- The active clamp time (t) is dependent on the circuit line parasitic inductance (L) and peak short current (i) with the formula  $V_{overshoot} = L \cdot di/dt$ . If the overshoot voltage across the Vce is higher, active clamp time is longer (due to longer decay time), so if the circuit line parasitic inductance or peak short current is higher, then overshoot voltage will be higher, and vice versa.
- On-board de-coupling design can reduce parasitic inductance and, in turn, reduce the overshoot voltage or active clamp time.
- The current through the TVS diode during active clamping is small. In this case, the surge or pulse duration time is typically at the microsecond level. We need to show that the energy passing through the TVS diode is at a level that the TVS diode can withstand without any issue. Figure 9 is the peak pulse power vs. pulse width time graph reproduced from the TPSMB TVS diode datasheet. During active clamping, for surge voltages across the TVS diode higher than 500 V at a short duration pulse, it shows the peak power (the point indicated by the arrow in Figure 9) is at  $656 V \cdot 0.5 A = 328 W$  at 2  $\mu$ sec, which is far below the TPSMB TVS diode's pulse width peak power rating (around 10 kW at 2  $\mu$ sec as listed in Figure 9). That means the TVS diode will survive this short duration surge during active clamping.

**Figure 9. TPSMB Series TVS Diode peak pulse power vs. pulse time**

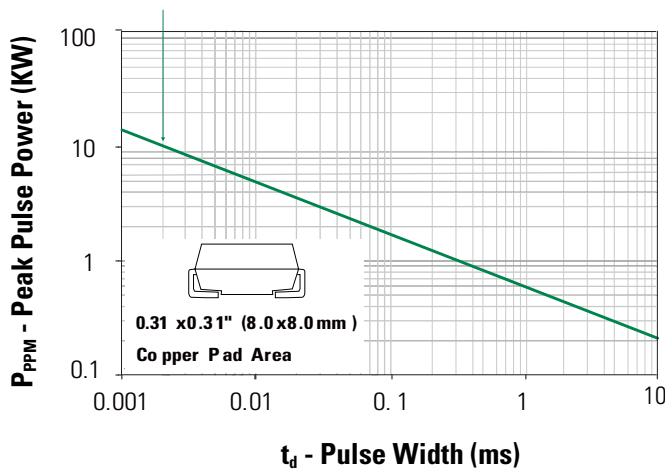

**Note:** Note that an IGBT or IGBT module is driven by an IGBT driver circuit or driver IC; a different driver IC or driver circuit will affect the driving performance. Normally, Rg value is critical to control the driving current to the IGBT, and a lower Rg in the driver line could produce a little higher TVS active clamp current. This application note is intended to illustrate the active clamp protection. Also, it is intended to show the low level of energy passing through the TVS diode (which does no harm to the TVS diode itself) during active clamp protection.

**Conclusion:** A high voltage TVS diode is a critical component for IGBT active clamping during an IGBT turn-off event and helps in operating an IGBT in a safe and active mode. Littelfuse offers a wide range of high voltage TVS diodes from 3.3 V to 650 V.

Please visit <http://www.littelfuse.com/products/tvs-diodes/automotive-and-high-reliability-tvs/tpsmb.aspx> for more information.