

440A Series

AEC-Q200 Qualified > Ceramic Fuse

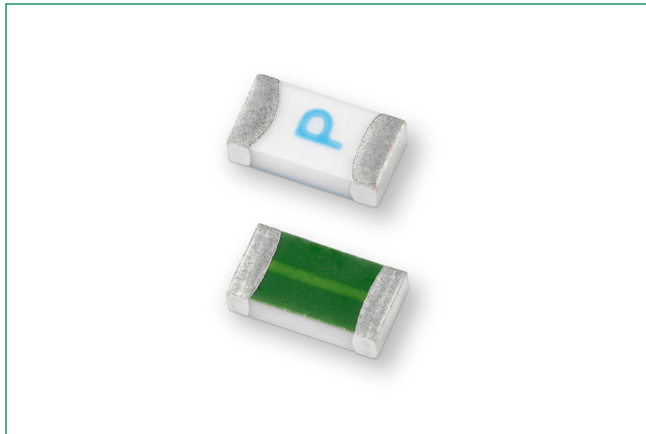

Description

The 440A Series AEC-Qualified fuses are specifically tested to cater to secondary circuit protection needs of compact auto electronics applications.

The general design ensures excellent temperature stability and performance reliability. This high I_{2t} fuse series is designed to have ultra high inrush current withstand capability to avoid nuisance fuse open.

Features & Benefits

- Operating Temperature from -55°C to +150°C
- 100% Lead-free, RoHS compliant and Halogen-free
- AEC-Q200 Qualified
- Ultra high I_{2t} values
- Fast response to faulty current to ensure over-current protection to sensitive electronic component
- Recognized to UL/CSA/NMX 248-1 and UL/CSA/NMX 248-14

Additional Information



Resources



Accessories



Samples

Applications

- Li-ion Battery
- LED Lighting
- Automotive Navigation System
- TFT Display
- Battery Management System (BMS)
- Cluster

Electrical Characteristics for Series

% of Ampere Rating	Ampere Rating	Opening Time at 25°C
100%	0.50A - 0.75A 1.75A - 8A	4 hours, Minimum
350%	0.50A - 0.75A 1.75A - 8A	5 secs., Maximum

Agency Approvals

Agency	Agency File Number	Ampere Range
	E10480	0.500A - 8A
	29862	0.500A - 8A

Electrical Specifications by Item

Ampere Rating (A)	Amp Code	Max. Voltage Rating (V)	Interrupting Rating (AC/DC) ¹	Nominal Resistance (Ohms) ²	Nominal Melting I ² t (A ² Sec.) ³	Nominal Voltage Drop At Rated Current (V) ⁴	Nominal Power Dissipation At Rated Current (W)	Agency Approvals	
0.5	.500	63	50A @ 63VAC/DC	0.8140	0.02642	0.4831	0.242	x	x
0.75	.750	63		0.4624	0.09312	0.3983	0.299	x	x
1.75	1.75	63		0.0450	0.3312	0.0777	0.136	x	x
2	002.	63		0.0385	0.4326	0.0792	0.158	x	x
2.5	02.5	63	50A @ 32VAC/63VDC	0.02850	0.8191	0.0747	0.187	x	x
3	003.	63		0.02252	1.232	0.0742	0.223	x	x
3.5	03.5	63		0.01845	1.789	0.0757	0.265	x	x
4	004.	63		0.01553	2.601	0.0709	0.284	x	x
5	005.	63		0.0120	4.761	0.0654	0.327	x	x
7	007.	63		0.00753	8.464	0.0696	0.487	x	x
8	008.	63		0.00634	12.95	0.0655	0.524	x	x

Notes:

1. AC Interrupting Rating tested at rated voltage with unity power factor. DC Interrupting Rating tested at rated voltage with time constant < 0.8 msec.
2. Nominal Resistance measured with < 10% rated current.
3. Nominal Melting I²t measured at 1msec. opening time.
4. Nominal Voltage Drop measured at rated current after temperature has stabilized.

Devices designed to carry rated current for 4 hours minimum. It is recommended that devices be operated continuously at no more than 80% rated current. See "Temperature Derating Curve" for additional derating information.

Devices designed to be mounted with marking code facing up.

440A Series

AEC-Q200 Qualified > Ceramic Fuse

Temperature Derating Curve

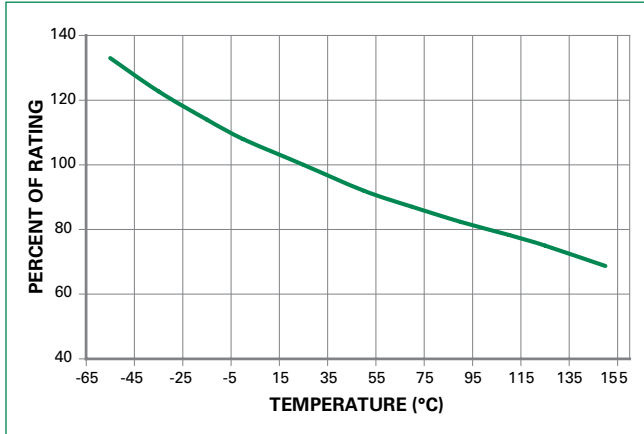

Note:

1. Derating depicted in this curve is in addition to the standard derating of 20% for continuous operation.

Example:

For continuous operation at 75 degrees celsius, the fuse should be derated as follows:

$$I = (0.80)(0.85)_{RAT} = (0.68)_{RAT}$$

Average Time Current Curves

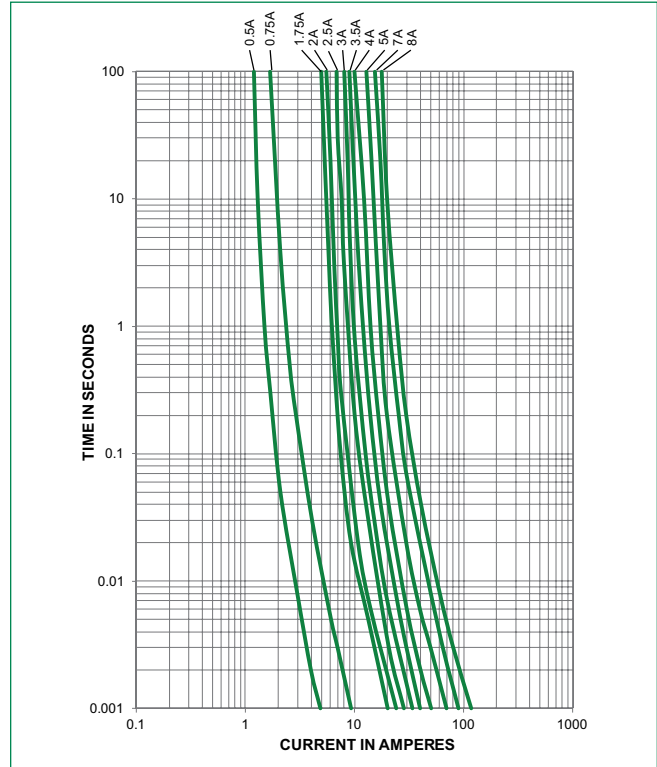

Soldering Parameters

Reflow Condition		Pb-free assembly
Pre Heat	- Temperature Min ($T_{s(min)}$)	150°C
	- Temperature Max ($T_{s(max)}$)	200°C
	- Time (Min to Max) (t_s)	60 – 180 seconds
Average Ramp-Up Rate (Liquidus Temp (T_L) to peak)		3°C/second max.
$T_{s(max)}$ to T_L - Ramp-up Rate		5°C/second max.
Reflow	- Temperature (T_L) (Liquidus)	217°C
	- Temperature (t_L)	60 – 150 seconds
Peak Temperature (T_p)		260 ^{+0/-5} °C
Time within 5°C of actual peak Temperature (t_p)		10 – 30 seconds
Ramp-down Rate		6°C/second max.
Time 25°C to peak Temperature (T_p)		8 minutes max.
Do not exceed		260°C
Wave Soldering	260°C, 10 seconds max.	

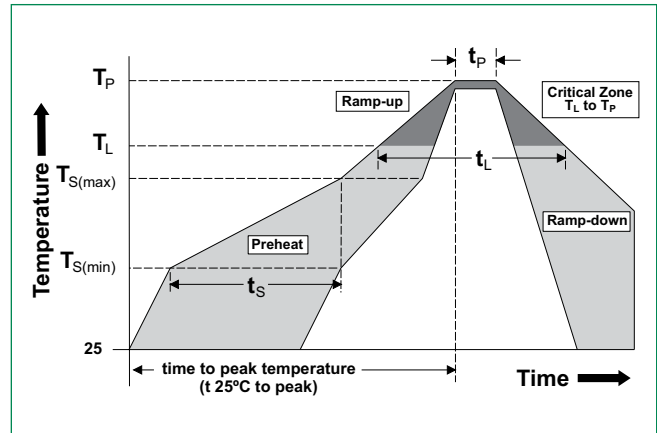

440A Series

AEC-Q200 Qualified > Ceramic Fuse

Product Characteristics

Materials	Body: Advanced Ceramic Terminations: Ag / Ni / Sn (100% Lead-free) Element Cover Coating: Lead-free Glass
Moisture Sensitivity Level	IPC/JEDEC J-STD-020, Level 1
Solderability	IPC/ECA/JEDEC J-STD-002, Condition C
Humidity Test	MIL-STD-202, Method 103, Conditions D
Resistance to Solder Heat	MIL-STD-202, Method 210, Condition B
Moisture Resistance	MIL-STD-202, Method 106
Thermal Shock	MIL-STD-202, Method 107, Condition B
Mechanical Shock	MIL-STD-202, Method 213, Condition A
Vibration	MIL-STD-202, Method 201
Vibration, High Frequency	MIL-STD-202, Method 204, Condition D
Dissolution of Metallization	IPC/ECA/JEDEC J-STD-002, Condition D

High Temperature Storage	MIL-STD-202, Method 108 with exemptions
Thermal Shock Test	JESD22 Method JA-104, Test Conditions B and N
Biased Humidity	MIL-STD-202, Method 103, 85C/85% RH with 10% operating power for 1000 hrs
Operational Life	MIL-STD-202, Method 108, Test Condition D
Resistance to Solvents	MIL-STD-202, Method 215
Mechanical Shock	MIL-STD-202, Method 213, Test Condition C
High Frequency Vibration	MIL-STD-202, Method 204
Resistance to Soldering Heat	MIL-STD-202, Method 210, Test Condition B
Solderability	JESD22-B102E Method 1
Terminal Strength for SMD	AEC-Q200-006
Board Flex	AEC-Q200-005
Electrical Characterization	Conducted at minimum, ambient and maximum temperatures

Dimensions mm (in.)

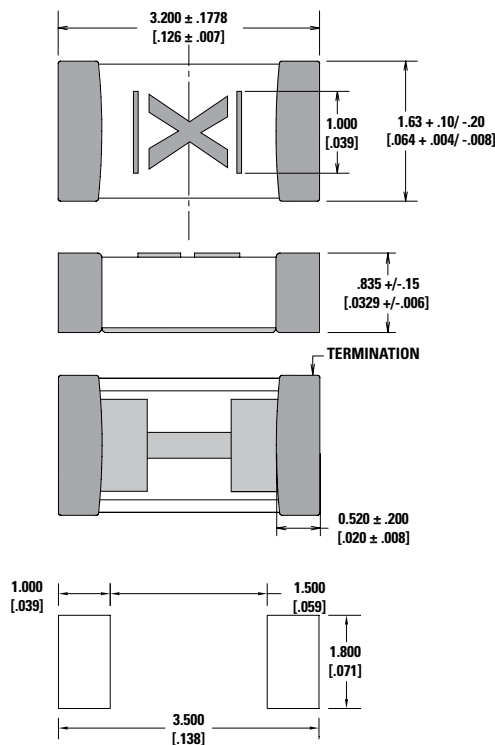

Part Marking System

Amp Code	Marking Code
0.500	F
0.750	G
1.75	L
002.0	\bar{N}
02.5	\bar{Q}
003.0	P
03.5	R
004.0	S
005.0	T
007.0	W
008.0	\bar{X}

Part Numbering System

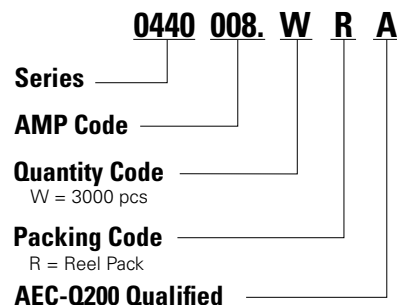

Packaging

Packaging Option	Packaging Specification	Quantity	Quantity and Packaging Code
8mm Tape and Reel	EIA-481, IEC 60286-3	3000	WRA

Disclaimer Notice - Information furnished is believed to be accurate and reliable. However, users should independently evaluate the suitability of and test each product selected for their own applications. Littelfuse products are not designed for, and may not be used in, all applications. Read complete Disclaimer Notice at: www.littelfuse.com/disclaimer-electronics