

⚠ DANGER!

HAZARDOUS VOLTAGES MAY BE PRESENT DURING INSTALLATION.
Electrical shock can cause death or serious injury.

Installation should be done by qualified personnel following all national, state and local electrical codes.

The Model 250100 is a three-phase voltage monitor designed to protect medium voltage motors regardless of horsepower. It will protect 50 to 60 Hz motors from damage caused by single phasing, phase reversal, voltage unbalance, low voltage and high voltage. Added features include DPDT contacts and an adjustable restart delay.

CONNECTIONS

1. Mount the MotorSaver® in a convenient location in or near the motor control panel. If the location is wet or dusty, the MotorSaver® should be mounted in a NEMA 4 or 12 enclosure.
2. The MotorSaver® should be connected to the secondary side of a 120VAC, 5VA potential transformer. Connect the 120V three-phase secondary to L1, L2, and L3 on the MotorSaver® terminal strip (see Figure No. 1).
3. Connect the output relay to the circuitry to be controlled (see Figure No. 1 and Figure No. 2).
 - A. To control a motor, connect the normally open contact in series with the magnetic coil of the motor starter as shown in Figure 1.
 - B. To sound an alarm, connect the normally closed contact in series with the alarm as shown in Figure 2.

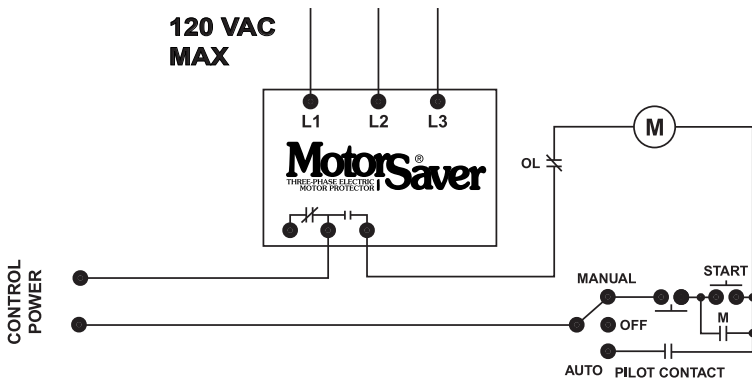

Figure No.1: Typical Motor Control Wiring Diagram



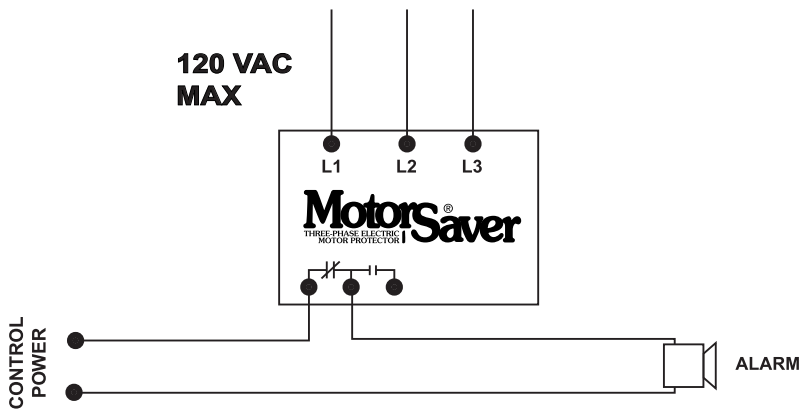

Figure 2: Typical Alarm Wiring Diagram

SETTINGS

1. **LINE VOLTAGE ADJUSTMENT:** Rotate the LINE VOLTAGE ADJUSTMENT to the nominal three-phase secondary voltage of the potential transformer.
2. **TIME DELAY RESTART (RESTART DELAY):** Rotate the RESTART DELAY to the desired position. The restart delay is the time between the MotorSaver® seeing acceptable power and the MotorSaver® closing its output contacts. The restart delay should be set appropriately for the individual application. If the RESTART DELAY is in the MAN (manual) position, then the unit will not automatically restart until it is turned out of the MAN position.

POWER-UP

Turn on the power to the motor. The MotorSaver® then goes through its restart delay and the LED will flash green (see Table 1). After the restart delay, the MotorSaver® will energize its output contacts and the RUN LIGHT will turn solid green. If the contacts do not energize and the RUN LIGHT does not turn solid green, then see the TROUBLESHOOTING section.







RUN	GREEN
RESTART DELAY	 GREEN
REVERSE PHASE	 RED
UNBALANCE / SINGLE PHASE	 RED
HIGH / LOW VOLTAGE	RED

Table 1: Diagnostic Indicator Lights

TROUBLESHOOTING

SYMPTOM	LIGHT PATTERN	SOLUTION
No lights are on. The unit seems completely dead	N/A	Measure the three line-to-line voltages. If any of the voltages are below 150 VAC, the MotorSaver® does not have enough power to operate its internal electronics. This may occur on a single-phased system. If the voltages are correct, call SymCom at 1-800-843-8848 or 1-605-348-5580.
Red light is blinking (On initial installation power up).	 RED	Turn off the three-phase power. Swap any two leads powering the MotorSaver® (L1, L2, or L3). There is a 50-50 chance of connecting L1, L2, and L3 correctly the first time. Re-apply the three-phase power.
Red light is blinking (After the motor has been previously running).	 RED	The incoming lines have been reverse phased. The MotorSaver® is preventing the motor from running backwards. Correct the phase sequence.
Red light is blinking in this pattern.	 RED	The voltage is unbalanced or single-phased. Measure the incoming line voltages and calculate the % unbalance. If the voltage unbalance does not exceed the % unbalance reset value, call SymCom at 1-800-843-8848 or 1-605-348-5580.
Red light is on steady.	RED	The voltage is out of tolerance. Measure the three line-to-line voltages. Calculate the average of the three voltages. If the average is 7% above or below the nominal voltage as selected by the LINE VOLTAGE ADJUST, the MotorSaver® is functioning properly. If the voltage is within $\pm 7\%$ of the selected line voltage, call SymCom at 1-800-843-8848 or 1-605-348-5580.
Green light blinks, but motor is not running.	 GREEN	The MotorSaver® is in restart delay.
Green light is on steady, but motor does not start.	GREEN	The MotorSaver® is in run mode. Ensure other control devices are allowing the motor to start. Check control circuit for loose wires or malfunctioning switches.

SymCom warrants its microcontroller based products against defects in material or workmanship for a period of five (5) years* from the date of manufacture. All other products manufactured by SymCom shall be warranted against defects in material and workmanship for a period of two (2) years from the date of manufacture. For complete information on warranty, liability, terms, and conditions, please refer to the SymCom Terms and Conditions of Sale document.

* The 520 Series has a one (1) year warranty and the LSRU series has a two (2) year warranty.

SPECIFICATIONS

3-Phase Line Voltage	95 to 120 VAC
Frequency	50 or 60 Hz
<i>Note: 50 Hz will increase all delay timers by 20%</i>	
Low Voltage (% of setpoint)	
Trip	90%
Reset	93%
High Voltage (% of setpoint)	
Trip	110%
Reset	107%
Voltage Unbalance (NEMA)	
Trip	6%
Reset	4.5%
Trip Delay Time	
Low / High Voltage Faults	4 Seconds
Unbalance / Phasing Faults	2 Seconds
Restart Delay Time	
After a fault or complete power loss	Adjustable 2-300 Seconds
Output Contact Rating - DPDT	
Pilot Duty	480 VA @ 240 VAC
General Purpose	10 A @ 240 VAC
Transient Protection	IEC 1000-4-5 ; 1995 ± 6 kv
Power Consumption	5 Watts (maximum)
Weight	14 Ounces
Terminal	
Wire AWG	12-22 Gauge
Maximum Torque	7 inch-pounds
Operating Temperature	-40° to +70° C
UL	E68520

Visit our website at www.symcominc.com for our complete catalog and new product listings!



2880 North Plaza Drive, Rapid City, SD 57702
Phone: (800) 843-8848 or (605) 348-5580
FAX: (605) 348-5685